

Norwegian University  
of Life Sciences

**Master's Thesis 2023 30 ECTS**

Faculty of Landscape and Society (LANDSAM)

# **Riverscape Restoration: Tromsa River in Norway, after Dam Removal**

**Ingeborg Fjeldberg**

MSc Landscape Architecture for Global Sustainability (M30-GLA)



**Title**

Riverscape Restoration: Tromsa River in Norway, after Dam Removal

**Athour**

Ingeborg Fjeldberg

**Supervisors**

Main supervisor: Maria Gabriella Trovato, NMBU  
Co-supervisor: Morten Kraabøl, Multiconsult

**School:**

Norwegian University of Life Sciences (NMBU)  
Faculty: Landscape & Society (LANDSAM)

**Publication**

January 2023

**Description of figure references**

Produced by author unless other sources are named. All graphics are fully references in the list of figures at the end of this document.

**Format**

A4, portrait (21,0 x 29,7 cm)

**Pages**

202

**Keywords**

Dam, dam removal, hydropower, ecology, ecological connectivity, restoration, landscape ecology, landscape architecture, trout, grayling, wetland, river, riverscape, riparian vegetation, delta, biodiversity, Tromsa, Fåvang, Gudbrandsdalen, Lågen.



# Riverscape Restoration: Tromsa River in Norway, after Dam Removal



## Acknowledgments

Thank you to everyone who has supported me through this semester, both familiar and new relations. Thank you to Everyone that has helped me by sharing their time, knowledge, and advice. I am grateful to Multiconsult, which introduced me to the project site, and to Morten Kraabøl, who has been my co-supervisor and has been working on the dam removal project, facilitating the migratory fish. Finally, my primary supervisor Maria Gabriella Trovarto has been important to me during this period and has guided and helped me in the best ways possible with great engagement.

## Abstract

Dams have been created in existing waterways to serve humans for centuries. For example, they have been used for different purposes, such as timber floating, grain mills, or electricity production. Today many of these dams remain unused and abandoned, disrupting ecosystems as they prevent the water from flowing naturally in the waterways. These human-made structures split habitats, fragment the landscape, and create hazards for migrating fish and other organisms living in the water. This global fragmentation raises concerns about habitat loss which may lead to species degradation and, in some cases, even distinction of certain species. As we know, nature is an interlinked web of ecological and geological processes where species are dependent and co-dependent on each other. When species disappear or populations dramatically decrease, it can cause chain reactions with an unknown outcome. An effort to help nature heal on sites at a local scale might also help at a broader scale as the number of restored sites increases.

This thesis focuses on the case of the Tromsa river in Norway. At this site, a dam stopped being used for hydropower production in the 1960s and was partly removed in 2022. Such changes have considerable effects on the ecosystem in and around the river and affect any surrounding ecosystem. Through landscape analysis of the area, one solution was proposed, which evolved around recreating wetland areas similar to the site before and the remaining wetland areas. Any significant findings were generally that the place needs more harmony with the ecology and that important wetland areas have been transformed to serve anthropogenic interests. The proposal facilitates ecological connectivity and favors the migrating fish species, trout, and grayling, that have the Tromsa river as an essential part of their habitat. Parts of this thesis, such as analysis and discussion, are mainly represented graphically, supplemented with text where an explanation is needed.



# Content

## 1. Introduction

## 2. Literature review

2.1	Global perspective state of the art	p. 16
2.2	The dynamic river	p. 20
2.3	Ecological connectivity	p. 22
2.4	Decommissioned dams	p. 28
2.5	Climate change	p. 30
2.6	National scale	p. 34
2.7	Dam removal practice	p. 38
2.8	Restoration for sustainable development of the world	p. 40
2.9	Relation between society and the gree environment	p. 42
2.10	Reference projects of dam removal and re-naturalization	p. 45
2.11	Methodology	p. 54

## 3. River Lågen and the township of Fåvang

p. 57

## 4. Project area

4.1	Project area River Tromsa	p. 64
4.2	Analyzing the landscape through its layers	p. 80
4.3	Habitat for trout and grayling	p. 134
4.4	The status quo	p. 138
4.5	Summarizing analyses	p. 156

## 5. Design

5.1	Strategy map	p. 164
5.2	Proposal	p. 168
5.3	Conlusion and reflection	p. 186

## 6. Bibliography

p. 188



Figure 1a. Colorful slate at the dam site, river Tromsa (Photo: Fjeldberg, I. 2022).



# 1. Introduction

## Scope

This thesis's main objective is to investigate the restoration potential of riverscapes after dam removal. In particular, it focuses on exploring socio-ecological strategies post dams deconstruction in Norway, selecting the river Tromsa as a case study.



Research question

In what ways can we sustainably restore a riverscape after dam removal?



Figure 1b. Remains of the dam in Tromsa river (Photo: Fjeldberg, I. 2022).



# UN sustainable development goals

The United Nation's Sustainable development goals are important reminders and guidelines for a better life for humans and the environment, as the goals address some of our most pressing issues. Several of these goals are relevant to river restoration, and the most relevant goals in this matter are listed below.

3 GOOD HEALTH AND WELL-BEING



*"Ensure healthy lives and promote well-being for all ages"* (United Nations, no date-a). In the case of the Tromsa river, this goal points to the need for available recreational space in nature, as access to nature and healthy ecosystems for harvesting and recreational use positively affect mental and physical health. Stakeholders at Tromsa use the riverside for recreation.

6 CLEAN WATER AND SANITATION



*"Ensure availability and sustainable management of water and sanitation for all"* (United Nations, no date-b). Basic human needs are access to safe water, sanitation, and hygiene. Unfortunately, population growth and water used in agriculture, industry, and energy production are some of the reasons for less access to clean water (United Nations, no date-b). This goal may be linked to the use of the water for the former hydropower production at Tromsa, as well as surrounding agriculture may deposit nutrients and fertilizers that may affect the ecology in the river Tromsa and Lågen.

13 CLIMATE ACTION



*"Take urgent action to combat climate change and its impacts"* (United Nations, no date-c). More frequent episodes of extreme weather lead to flooding, drought, and reduced species adapted to specific environments. These effects are, to some degree, visible globally. For example, at the Tromsa river, more frequent episodes of heavy rain and warmer temperatures are some of the effects of climate change. Adapting as best as possible to these changes is necessary to prevent even faster development.

14 LIFE BELOW WATER



*"Conserve and sustainably use the oceans, seas, and marine resources for sustainable development"* (United Nations, no date-d). Increased pollution and contamination are threatening marine and coastal ecosystems. An increase in sea level, which causes flooding of polluted land areas, and overharvesting of food resources are some threats to our marine ecosystems (United Nations, no date-d). The ocean drives the global water system, but waters in rivers and inland lakes equally affect the seas, as it is a part of the same system. Several species depend on the ecology of the river Tromsa. Among these are the migratory fish species Trout and Grayling, for example.

15 LIFE ON LAND



*"Protect, restore and promote sustainable use of terrestrial ecosystems, sustainably manage forests, combat desertification, and halt and reverse land degradation and halt biodiversity loss"*(United Nations, no date-e). Ecosystems are gradients, and ecology on land is equally important as ecology underwater to achieve thriving ecology below and above the water surface.

Figure 2. (Image source: United Nations, no date).

(United Nations, no date-f)

*"Water is the driving  
force of all nature"*

*- Leonardo da Vinci*

## 2. Literature review



# 2.1 Global perspective state of the art

Human-made barriers are affecting our planet's river system and waterways with a clear negative environmental impact. Today, dams for hydropower production and their effect on rivers are a heated topic, as we need energy. But unfortunately, many old dams are left without ongoing production while new dams are being constructed and planned for the future.

Damming up rivers for hydropower production is a practice that has grown strong roots worldwide and has long been associated with a sustainable and green way of producing energy. Water has been, and still is, a resource we define as renewable in many parts of the world. Looking at the world's renewable electricity production, which in 2020 made up around 24% of global energy production, hydropower contributed around 70% (Mulligan et al., 2020).

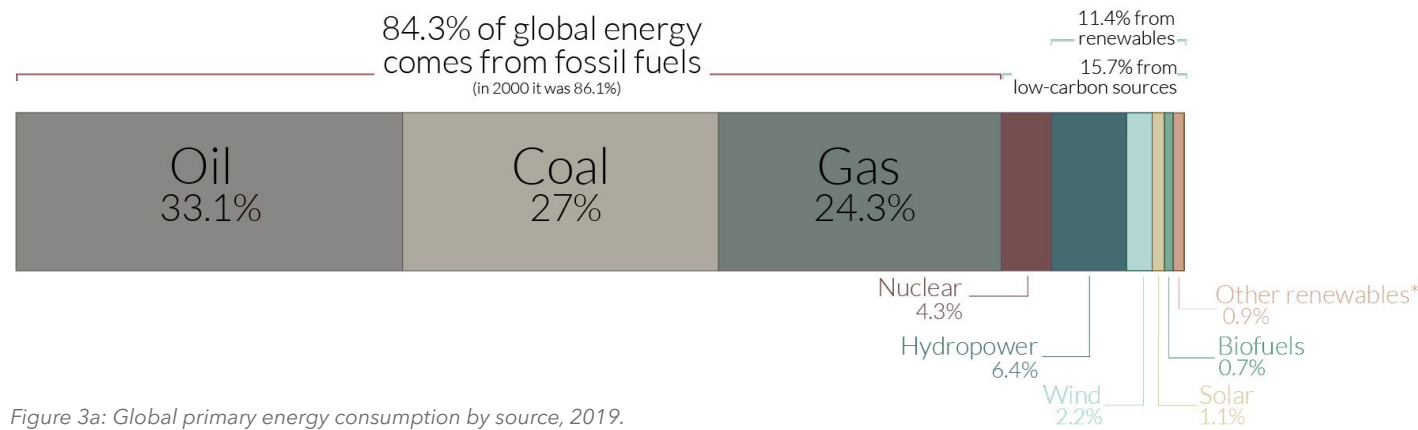

Figure 3a: Global primary energy consumption by source, 2019. (Based in figure by: Ritchie, H., 2019)

The maps on page 17 show existing dams in the world detected by the GOODD method of Mulligan et al., 2020. The technique used was manually going through Google Earth Imagery tiles and catching medium to large-scale dams. The smaller dams do not show here; only the ones big enough to be visually detected on googles satellite imagery (Mulligan et al., 2020).

The overview provides an overall impression of the distribution and places of higher concentration of hydropower production. In addition to the information the maps convey, they also show that dams are constructed mainly in developed countries with a topography supporting the constructions.

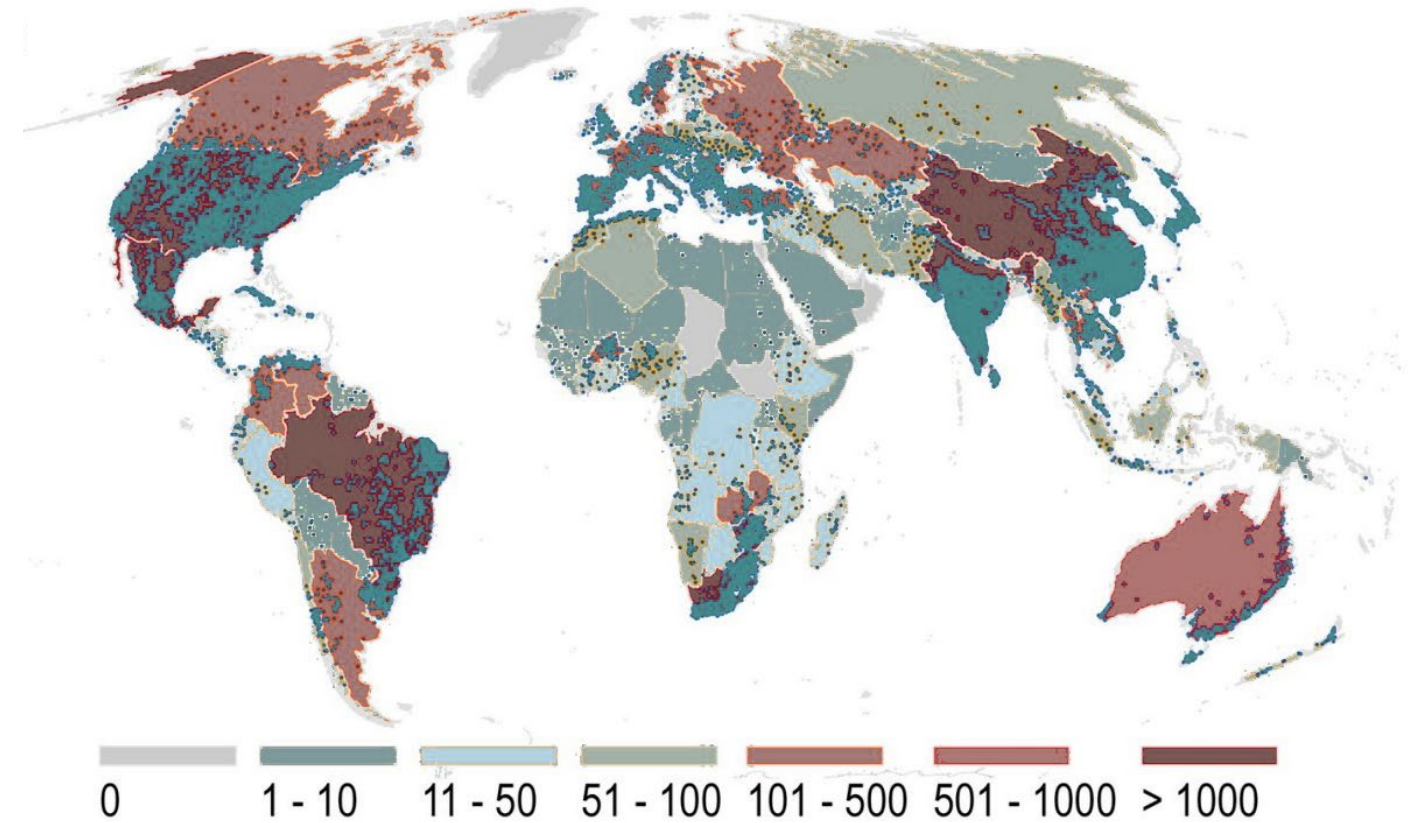

Figure 3b: Dams and catchments in GOODD database, Shows the number of dams in each country (grey to dark red) and individual dam locations (teal color) (Based on map by: Mulligan et al., 2020).

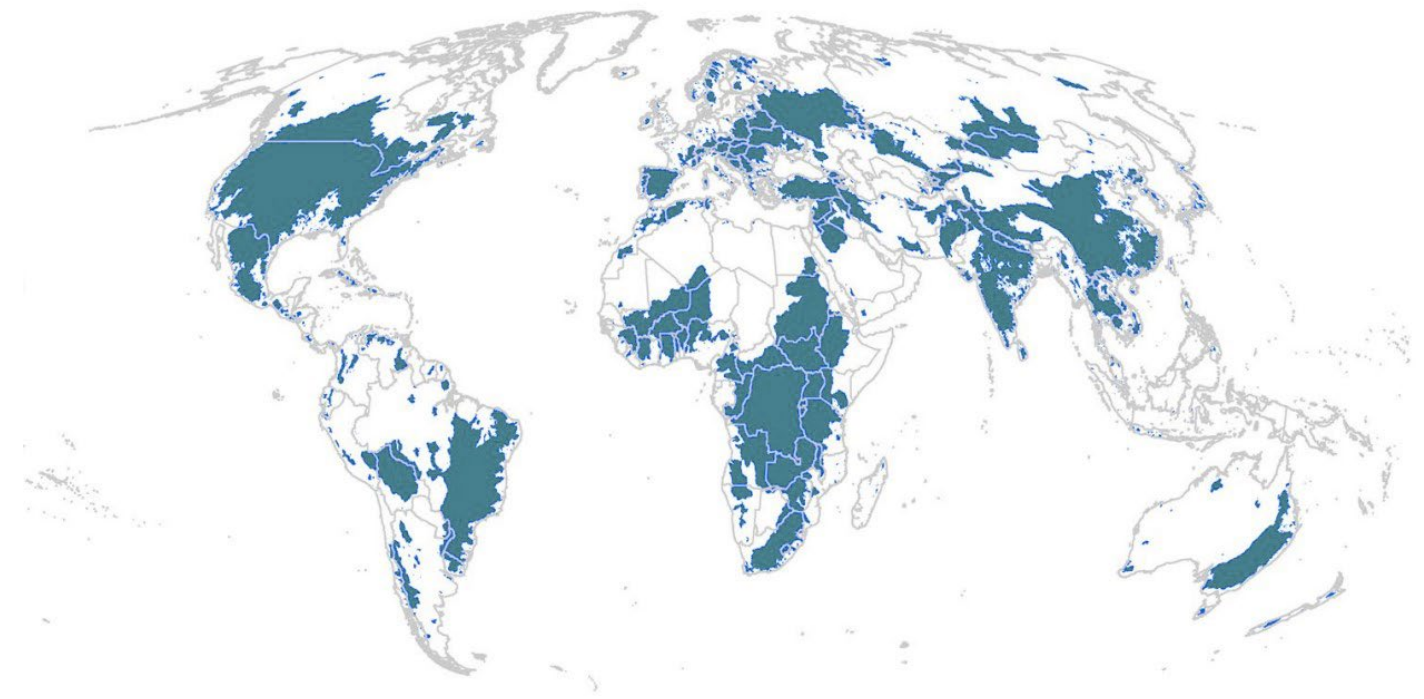

Figure 3c: The area of terrestrial land draining into a dam in blue, 2020. (Based on map by: Mulligan et al.)



Modern society needs to produce energy to continue the lifestyle we have acquired after electricity became an everyday supplement in homes at the beginning of the 1900s. Energy production has become a genuine necessity of survival in many cultures and parts of the world, as we need energy to cover basic needs such as heating, food preparation, and sanitation. For example, with the ongoing political conflicts, the cold winter temperatures could determine fatal consequences such as illness and even death among vulnerable community groups. This shows how dependent we have become on electric energy and how vulnerable we are to interference in our systems. There is a constant search for new sources, ways to produce energy, and locations to construct new facilities.

Given the impact that hydropower conversion of a river course can have on the local ecosystem, it could be considered that these areas will be less vulnerable than an unregulated one. By upgrading existing hydropower facilities, we could increase power production by 1/3. Some suggestions from researchers at the project AlternaFuture is to install bigger pumps and to expand the area of bigger existing magazines (Vereide et al., 2020).



Figure 4: Under the water surface of river Tromsa (photo: Fjeldberg, I. 2022).



## 2.2 The dynamic river

Glaciers shaped our valleys and rivers in the different ice ages, and the different shapes have appeared as a result of the type of geology in the landscape the river is running through, as well as the steepness of the valley or floodplain, to mention some factors. Softer geology erodes faster, and the more complex will maintain its shape for longer. The meandering rivers are rivers that erode sediments in the outskirts / the pools, leave transported sediments at the insides of turns, and as a result, often leave a river delta at the end of the river (Fossen, 2018). Figure 5b illustrates the movement of a meandering river. Thus our rivers and landscapes are constantly in the process of being shaped and reshaped.

The shaping of a river is a result of different processes. As Martin Prominski and colleagues (2017) describe in the book *River. Space. Design*, the processes of a river can be described as follows:

### 1. Temporary flow fluctuations Sub-process

- 1: vertical water level fluctuation Sub-process
- 2: the lateral spread of the water

### 2. Morphodynamic processes Sub-process

- 1: sedimentation shift within the river Sub-process
- 2: self-dynamic river channel development (Prominski et al., 2017, p. 20).

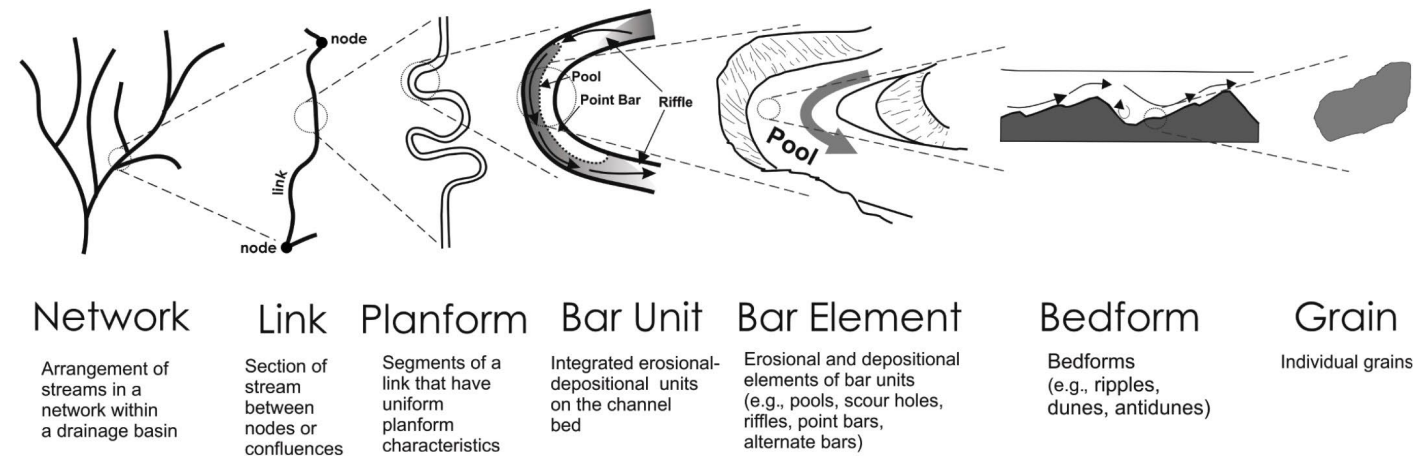

Figure 5a: Hierarchical morphological structure of alluvial river systems (Image source: Rhoads, 2020, p. 11)

Rivers are the primary transporter of sediments out to our oceans and have, in addition to the glaciers, contributed to shaping the Earth's surface into what it is today. On its way, water masses transport and shape the river by digging out sediments from the river banks, riverbeds, and on riversides. The deposits will be relocated downstream on the river sides and riverbed, and some will be transported out into the lake, ocean, or a connected river. How far the sediments will be transported depends on the grain size and the current's strength. Smaller particles will move further with the current, while the larger ones settle after a shorter distance, and the sediments will be rounder in shape and smaller when transported further away. Therefore, smaller rivers with weaker currents will not transport as big sediments as the larger rivers with more strength (Fossen, 2018). The infrastructure of a river is complex, but it can be related to infrastructure in the same way as what we build on land. Elements of a river and how they fit into the network are shown in figure 5a.

With industrialization, it became customary to channel rivers to control the water masses and use energy. Canalization has also been used for flood control, but this practice of handling water only makes the water masses even more challenging to control (Nienhuis & Leuven, 2001). Figure 5c illustrates the behavior of a channelized river versus a free, meandering river.

Climate and changes in weather will also determine the length of hydrological events. Changes, such as seasonal shifts with varying temperatures and rain- and snowfall, play a role in the movement and strength of water masses. In addition, the water discharge level determines the sediment transportation level and how fast the river changes its form. For example, large storms may produce variations in floods that can extend on large stretches of a river and last for several weeks in the bigger rivers (Rhoads, 2020). Below in figure 5d, examples of measured water levels during a year in three neighboring rivers of river Tromsa were collected

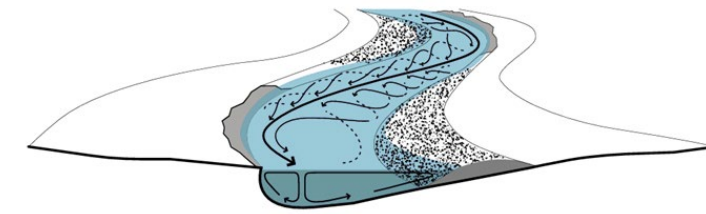
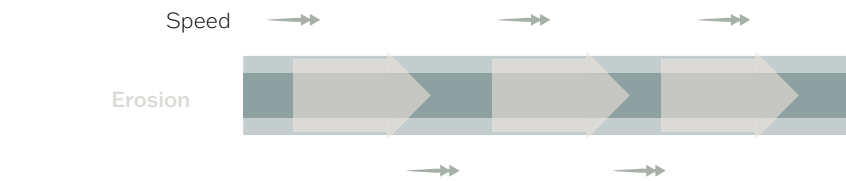

Figure 5b: River movement (Image source: Prominski et al., 2017, p. 22).

### Channelized river



### Meandering river

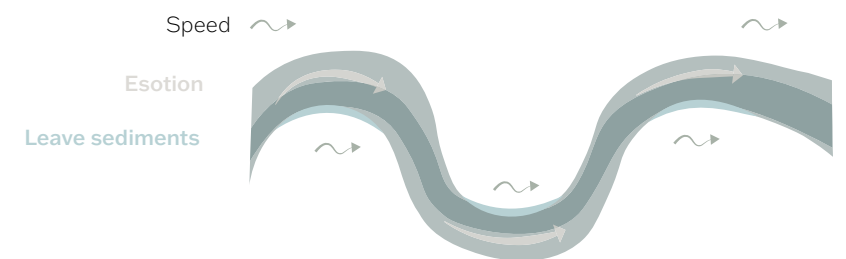
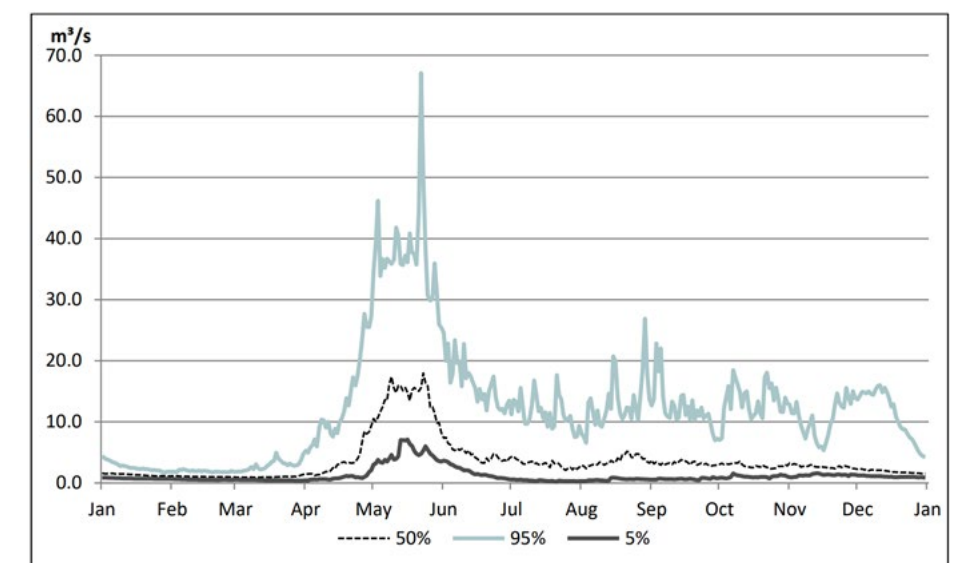

Figure 5c: Differentiation of channelized and meandering rivers (Diagram: Fjeldberg, I. 2022).

and processed by Multiconsult to predict possible water levels in the river Tromsa before the dam's removal. Figure 5d shows that estimated water levels in the river Tromsa are highest during May - June. Due to snow meltin g within this period. Higher water levels equal

higher erosion forces and sediment transportation due to the greater forces in the water. Moreover, a river's connections, processes, and movement are of vital importance to the river's ecological health.

Figure 5d: Estimated plots for river Tromsa showing assumed estimation of average discharge, flow rate for each nychtemeron. The graph shows the measured water level during the year; each number represents a percentile. Data were calculated and based on information from the Aulestad water station located on river Gusa as part of the prework for the dam removal. Two other graphs were also created from two different water stations, but I chose to include only this one, as Aulestad is closer to Tromsa in the distance. Multiconsult has created the report with hydrological calculations (Image source: Sørås et al., 2018, p.3).





## 2.3 Ecological connectivity

A natural and free-flowing water body in rivers is essential for ecological connectivity, not only for the movement of organisms but also for transporting sediments, organic matter, and solutes (Wohl, 2017). The movement of water masses allows the river to change its shape and appear differently year by year and, even more, decade by decade. The river's ecology adapts to and depends on water levels and flooding shifts. The constant movement of gravel and sand particles is essential for several fish species, as it facilitates refuge and spawning areas (Fylkesmannen i Sør-Trøndelag, 2014). And in the same way, we wish to have a varied landscape above the water surface to maintain ecological variation and healthy ecosystems; this is just as important below the water surface. For example, some fish follow the water levels and swim up in smaller channels for spawning or refuge when the water level rises. They swim back into the larger river when the water level drops (Shao et al., 2019). These migrating species are vulnerable to barriers preventing them from following their natural life cycle and putting potential habitats out of reach (Myrvold, 2022). Ecological connectivity is described as follows by Myrvoll, 2022 in an article honoring the world day of fish migrations, May 20:

- Length connectivity: the transportation of water, sediments, and nutrients downstream. Allows for fish and other organisms to move upstream.
- Width connectivity: allows the river to flood areas of the river bank. This is important for sorting sediments, exchanging nutrients between land and water, and creating habitat and refuge for organisms.
- Vertical connectivity: enables the interaction between groundwater and surface water. This movement slows down the temperature changes and stabilizes the water flow.
- Connectivity over time: where the water is flowing at any given time varies with seasons, thus maintaining the ecological range of variation to which the organisms are adapted.

(Myrvold, 2022).

Shao et al., 2019 mention that there are additional parts of connectivity across spatial axes; "for example, when climate (e.g., precipitation) is combined with these dimensions, the concept is expanded to hydrologic connectivity on the landscape, regional, and even global

scales" (Shao et al., 2019, p. 23). In landscape ecology, we speak about patches, boundaries, edges, etc. We can use the same terms underwater, but this becomes more fluent and complex in a river. The river may be seen as one corridor, with arms stretching into smaller rivers and streams. For a fish, for example, this infrastructure of water is crucial. By constructing a barrier somewhere along this corridor, several opportunities will be cut off, and maybe the possibility of migrating to different and vital parts of the river system will disappear. Loss of connectivity may also lead to the deterioration of water quality and simplification of the biota community composition due to the lack of movement in the water. A build-up of polluted sediments may also occur upstream, and an accumulation of dead organic material may lead to water pollution (Kuriji et al., 2021). Ecological connectivity is also essential for developing the species and reproducing healthy individuals. Habitat fragmentation has reduced genetic diversity, as species have fewer opportunities to exchange genes in closed-off populations (Junge et al., 2014).

Humans have changed the systems of rivers and are affecting their natural processes and availability to move and evolve freely and provide the desired ecosystem services by canalization, building water reservoirs, and adding other types of barriers to water courses (Rhoads, 2020). Szatten & Habel state in a report from 2020 that "Generally, more than 50% of the large rivers in the world have lost their hydromorphological and ecological continuity" (Szatten & Habel, 2020, p. 1). This results from the construction of dams and reservoirs, and the number will increase dramatically when considering future planned constructions (Habel et al., 2020).

Rivers cover only 0,58% of the Earth's surface, but the oceans comprise 71%, glaciers 10%, and lakes 2 - 3,5%. As all rivers are connected to the Earth's hydrological cycle, their health is an important topic to consider (Rhoads, 2020), and riparian vegetation significantly influences the river's health.

## Riparian vegetation

Vegetation along riverbanks and the edge zones of the water is essential for a thriving ecosystem and life in the water (Xiang et al., 2016). For example, insects use the leaves of plants to rest and dry their wings, and they may lay their eggs on plants. Both insects, mammals, and benthic invertebrates may use the stalks and leaves of plants as shelter. In addition, insects are an essential food source for fish and birds and work as pollinators (Bjerkely, 2018).

Dead organic material falling into the water makes up all the biological energy in the lotic environment. It is stated that 75-80% of the nutrition in rivers originates from the land areas. Therefore the vegetation's presence is crucial for life in the rivers (Fergus et al., 2010). This is different in the lentic environment, where there is no continuous running stream transporting energy (Rosset et al., 2017). Instead, phytoplankton produces nutrients and oxygen for other organisms in lentic waters through photosynthesis (Cowan, 2022). The vegetation may also prevent erosion at the riversides by holding the ground together with the roots. As roots extract and filter nutrients and sediments, water contamination may be reduced. For example, Nitrogen and Phosphorous are added in agriculture with fertilizers, and excess runoff into waters is a big problem in some places. Plants in riparian zones extract the runoff before reaching the water and use the nutrients for their benefit (Staubo et al., 2019). The vegetation traps the sediment, particle-bound nutrients, and heavy metals and takes up dissolved nutrients. They filter the water and release dissolved organic carbon (Rowiński et al., 2018). In addition, the branches and leaves provide refuge for the fish (Pulg et al., 2017). The vegetation also works as flood control, and trees play an essential role even in rapid alpine rivers. Protecting the older trees that have grown without stress is beneficial as they have developed a more structured root system,



Figure 6a: Alnus Incana along the riverside of Tromsa (Photo: Fjeldberg, I. 2022).



Figure 6b: Parts of the riparian vegetation along Tromsa river (Photo: Fjeldberg, I. 2022).



making them stronger and more stabilized (Andreoli et al., 2020). And as Opperman et al., 2009 states it: "Flood risks will likely increase because of both climate change (1) and shifting land uses, such as filling of wetlands and expansion of impervious surfaces, that lead to more rapid precipitation runoff into rivers" (Opperman et al., 2009). Figure 6d shows zones with different importance for the river and what vegetation type is expected to be found.

The Norwegian planning and construction law § 1-8 says that "within the zone stretching 100 meters inland, along seaside and waterways, special consideration must be given to the natural and cultural environment, outdoor life, landscape, and other public interests" (Plan- og bygningsloven, 2021). This paragraph may sound anthropogenic-oriented, but the words 'natural' and 'landscape' support biodiversity. And to use any land areas for recreation or to prevent surrounding areas from becoming unavailable, we must take flooding into consideration. NVE mentions in their report about riparian vegetation that river banks and plains are examples of nature that can mitigate the effects of floods and should be safeguarded as far as possible in spatial planning (Staubo et al., 2019).

Figure 6c: Example of thriving riparian vegetation at Tromsa seen from the river (Photo: Fjeldberg, I. 2022).



Habitat, organic matter, sediments and nutrients flow

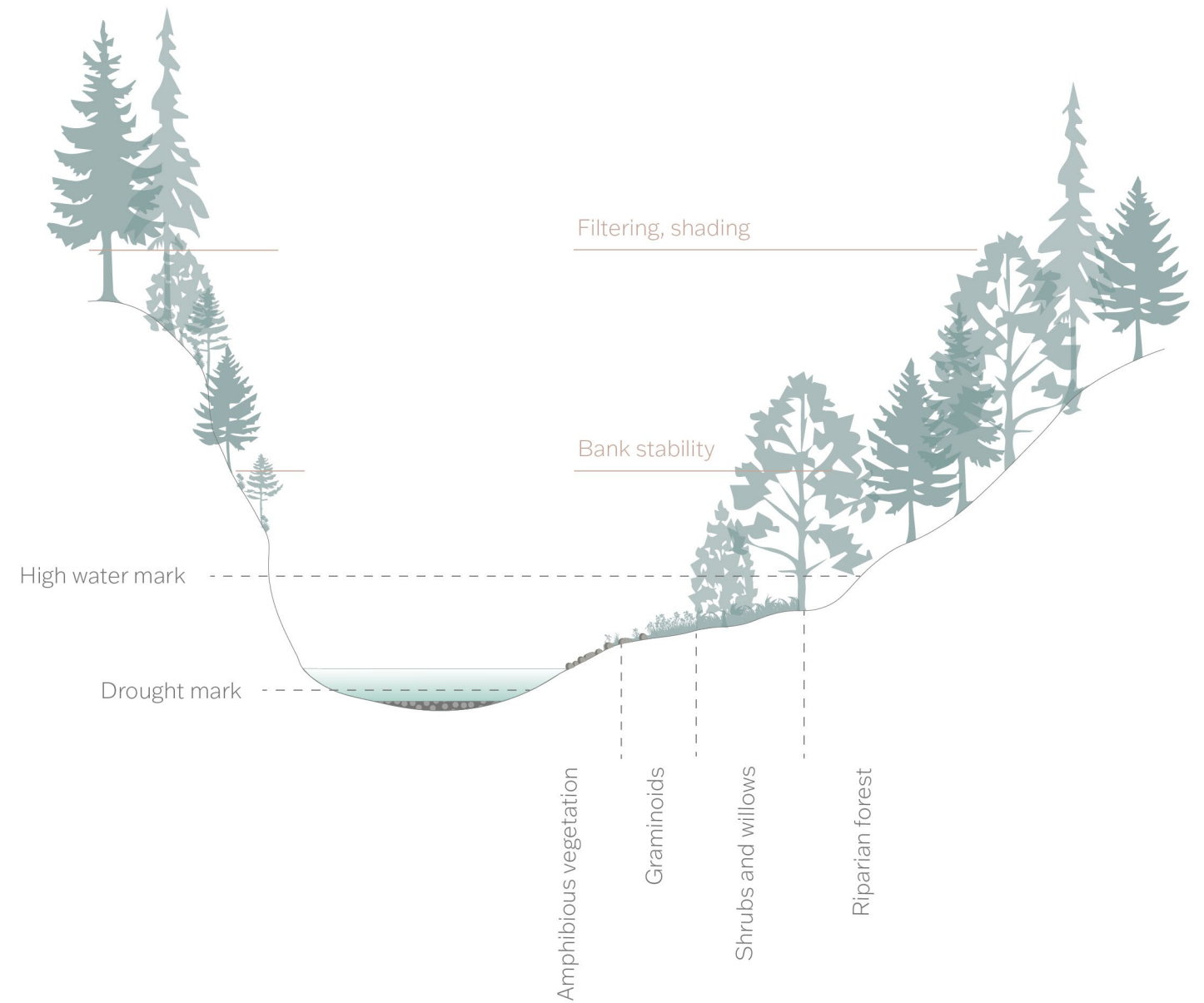

Figure 6d: Explanation of vegetative zones at river sides (diagram: Fjeldberg, I. 2022).



# Wetland and river deltas

As mentioned in the chapter *The Dynamic River* (p.20), river deltas appear at a river outlet due to the sediments transported by the river if the topography allows it. The processes and evolution of a river delta are explained in figure 7. Within the delta and its surroundings, there are often a presence of wetlands. Connected to meandering rivers, you may also often find wetlands at the river sides at the bottom of valley landscapes. The wetlands are part of the riparian zone, but there are several types of wetlands; how flooded they are, how long the period is, and how directly they are connected to the river determines what vegetation is there (Casanova & Brock, 2000). For example, a marsh is a wetland that holds water for long periods. They are flooded in wet seasons but typically keep the water at all times (Galen & Newman, 2022). Flooded meadows are a bit less wet and allow grazing animals to walk in without sinking into the soil. They contain little or no peat, and vegetation is low to medium in height (Artsdatabanken, no date-b). As described for the riparian zones, wetlands also improve the water quality through natural processes by filtering pollution from flood and stormwater through vegetation, soils, and microbial assemblages. In addition, they slow down floodwater (Galen & Newman, 2022), and flooding is necessary for transporting and circulating sediments and organic material (Fylkesmannen i Sør-Trøndelag, 2014). Finally, wetlands work as carbon sinks, and studies have shown that wetlands holding more water may also store even more carbon (Limpert et al., 2020). In addition, this nature type provides habitats for many wetland birds of national interest to protect insects, plants, and mammals which are all critical for biodiversity (Hind, 2020).

Due to the flat topography and often stable sediments, river deltas and the surrounding wetlands tend to become built up. In the world, over 500 million people live in the areas of river deltas (Kuenzer & Renaud, 2012). In Norway, where steep mountains dominate the landscape in many places, a significant part of all river deltas has been affected either by housing, infrastructure, or agriculture. Additionally, due to organic material in the geology, the soil of river deltas is often nutrient-rich and great for agriculture. Gudbrandsdalen valley is no exception (Fylkesmannen i Sør-Trøndelag, 2014).

In Norway, the law on water resources (Vannressursloven), in paragraph § 11, first sentence, is on protecting the vegetation zone along rivers and streams. It says that a natural vegetation zone must be maintained that prevents runoff and provides habitats for plants and animals. The municipality may decide the width of this vegetation zone (Vannressursloven, 2001a). Furthermore, because there are no set rules for the width of these zones, it differs from location to location how well they function. Moreover, river barriers affecting the natural flow of water will also impact the water flow in the surrounding wetlands.

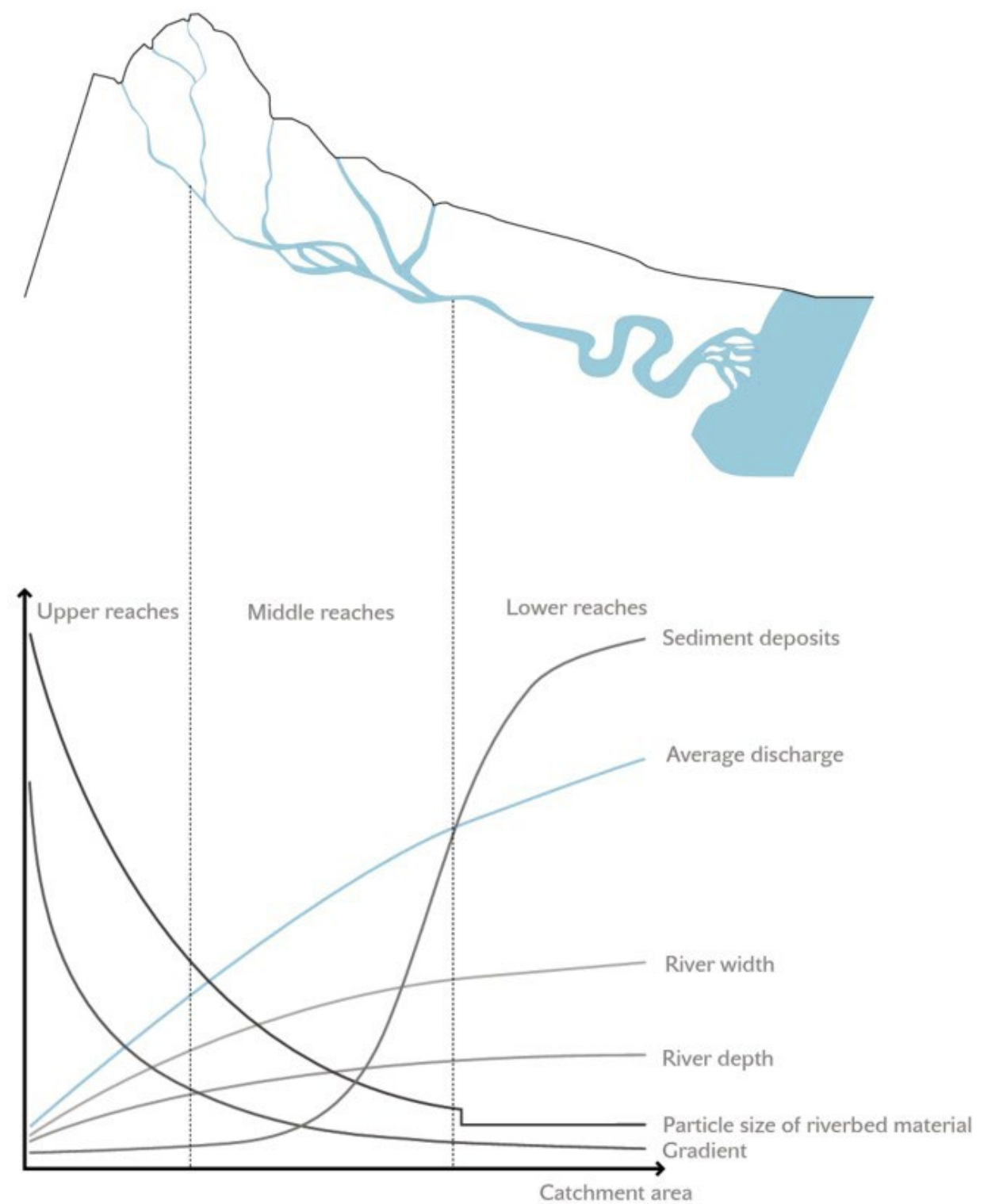

Figure 7: Description of how the transportation of sediments and how a river changes its from (Image source: Prominski et al., 2017 (p. 27)).

# Environmental side effects of hydropower production

In search of ways of producing energy, nature's resources have been used as an asset, often without fully considering the future consequences. From a greater sustainability perspective, hydropower production has long been associated with green, clean energy. However, with time, research, and increasing multi-disciplinary knowledge, it has become clear that this method of energy production is not entirely free from damaging side effects. The natural world and its ecosystems are getting more fragmented every day, and the construction of dams and reservoirs fragments the blue infrastructure on our planet by creating barriers for migrating species, often with more complex ecological impacts.

Hydropower generation from stored water in reservoirs contributes to greenhouse gas emissions when the draw-down of water levels exposes muddy sediments in the littoral zone of the reservoirs. Up to 80% of the gases are methane, which is 80 times more potent than carbon dioxide. The gases are released by continuous diffusion across the reservoir's surface and exposed shorelines, bubbling from sediments and via transport

through phytoplankton and larger plants within the reservoir (Catlett, 2022). When constructing dams, the ecological functions and morphological connectivity may change, and sometimes it will not be possible for organisms to pass the barriers, leading to reduced connectivity between vital habitats. These barriers affect the ecology and the river system in several ways, as described in the chapter Ecological connectivity at page 22. Recently it has also been highlighted that migrating fish and other organisms often get killed by the turbines in several operating hydropower stations (Algera et al., 2020).

Along with ongoing climate changes and loss of biodiversity, environmental processes have been transformed, and dramatic changes in temperature and rainfall cycles are documented (IPBES, 2019). Due to the scarcity of rain and snow in 2022, the regulated reservoirs in Europe and southern parts of Norway struggle to deliver water for energy production. Therefore, it has become clear that water is not entirely renewable, which also makes hydropower production not fully a renewable production method.

## 2.4 Decommissioned dams

Hydropower production will most likely still be part of our energy sources in the coming future. But an enormous number of existing dams are no longer in use and are not even being maintained. These dams have been used not only for hydropower but also for timber floating, grain mills, old water reservoirs, or recreational use, to mention some examples. Upgrading reservoirs to be used for power production is highly expensive. From an ecological perspective, when a dam is no longer in service, it has lost its original purpose. It is left as a barrier to fish and other water-thriving organisms. Its removal could decrease the number of ecological barriers on waterways.

In Norway, dams are registered and controlled by The Norwegian Water and Energy Authority (NVE), and they are classified in a system to describe the possible level of danger in case of breakage (NVE, 2021a).

Undiscovered, abandoned dams may not be maintained and looked after and can threaten nearby housing, people, and animals around the area.

In 2019 the Norwegian Institute of Nature Research (NINA) and Multiconsult published a report based on a study intending to reveal the location of unused,

Consequence Class	Housing units	Infrastructure and functions	Environment and property
4	>150		
3	21-150	Damage on highly trafficked roads, railways, or other infrastructure essential for life and health	Great damage to essential environmental values, or great damage on someone else's property
2	1-20	Damage on highly trafficked roads, railways, or other infrastructure important to life and health	Great damage to important environmental values or on someone else's property
1	Temporarily residence equivalent to <1 permanent housing unit	Damage to less trafficked roads or other infrastructure with relevance of life and health	Damage to environmental values or someone else's property
0	No consequences		

Figure 8a: Classification table of dams (table: directly translated by Fjeldberg, I. Source: NVE, 2021).

abandoned dams in Norway. The study showed that only 21% of the reported dams were registered in the Norwegian database Dampunkt at NVE (Eloranta et al., 2019). As so many dams in rivers have been installed freely without surveillance, other organizations have become aware of this and aiming to map out the locations. AMBER (Adaptive Management of Barriers in European Rivers) barrier tracker is an interactive tool used by the public to locate dams and other barriers in

rivers and streams. Location and barrier type are registered in a database available as an interactive map and in the format of an app that can be installed on smartphones (AMBER, 2022). The map in figure 8b is made by AMBER and indicates the location of 630 000 barrier records in Europe. The fully existing dataset includes almost twice as many discovered barriers and can be explored on AMBERS web pages (AMBER, 2022).

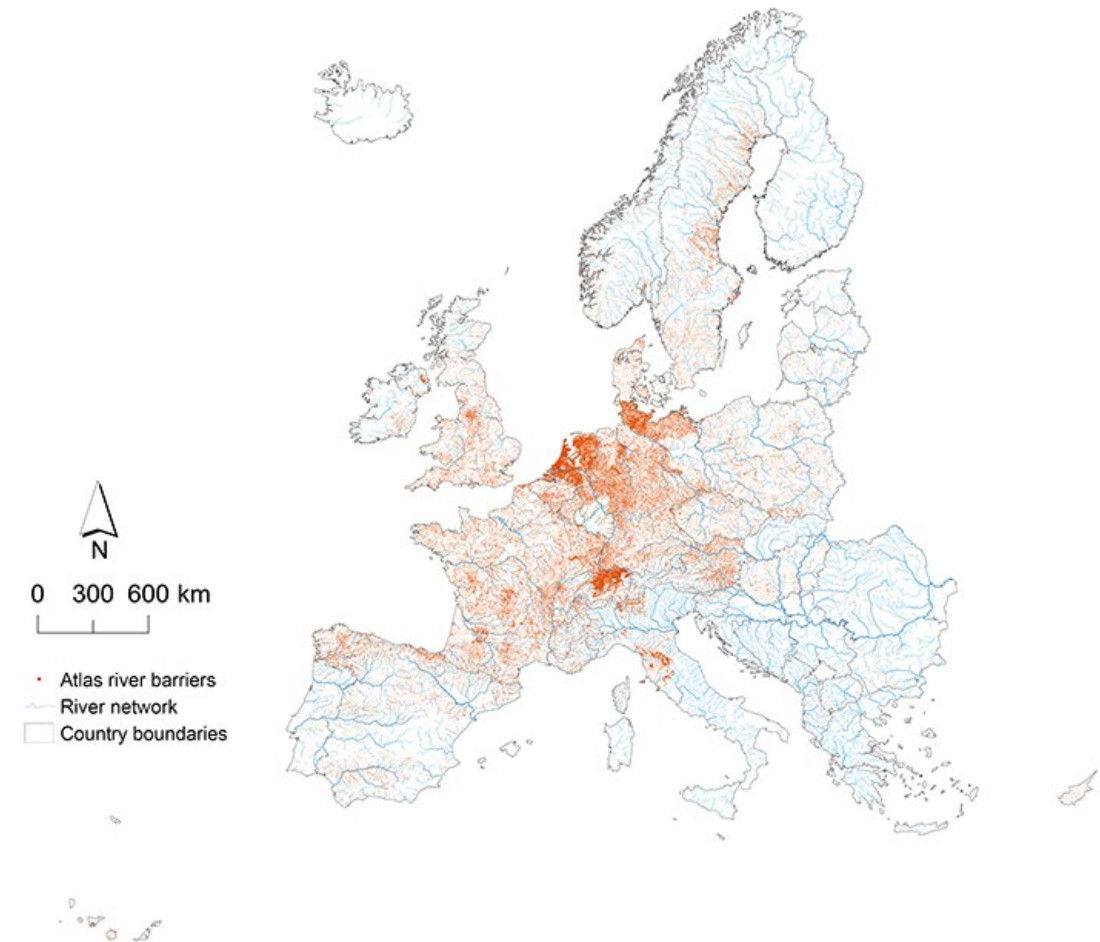

Figure 8b: An representation of existing barriers in waterways in Europe (Image source: AMBER, 2022).

On the other hand, abandoned dams can have acquired esthetical values for the community living close to a dam. For example, many dams provide recreational opportunities such as swimming, fishing, and the enjoyment of being close to still water or a "waterfall." Species may also have settled in and around the dam. The environment might then suddenly provide the perfect habitat, for example, for the Crested Newt and other species of national interest (NVE, 2019).

Decommissioned dams may also enhance cultural heritage that is of national interest to preserve. In Norway, 227 water facilities have been elected as part of the cultural heritage, and more will be selected by NVE (NVE, 2022b).



## 2.5 Climate change

Our world is changing at a high speed. Temperatures are increasing, which causes chain reactions: the arctic is melting, the sea level is rising, and in some places, episodes of heavy rainfall happen more often, while in other parts of the world, rivers and lakes are drying up. Rain with high intensity and frequent intervals may cause erosion problems, such as avalanches and flooding significant land zones. In addition, massive tornados appear more threatening than they used to be, and wildfires have become harder to control (IPCC, 2022). Nature and the climate are complex systems. Thus, it is understandable that it takes time for society to realize what is happening. Catherine Leyson et al. define the processes for climate change as follows: "For the majority of people it is the circumstantial, suggestive, remembered and observed changes to the weather and seasons that form the basis of an understanding of what is changing, if not why"(Leyshon et al., 2019, p. 454). Reports from all over the world provide us with shocking news, urging

us to take action to save planet Earth. For example, large rivers and lakes, such as the Mississippi river in the USA, had areas so dry that people could walk on foot to islands normally only accessible by boat. When the river dries up, it may also cut off vital food resources for people and other animals (Bergeron, 2022). In 2019 the Washington Post analyzed the development of global warming on the Earth. They used data from scientists and other academical groups and found that about 10 percent of the planet over the last five years had exceeded warming by over 2 °C (Mooney, 2019). As shown in a more recently constructed map below, southern Europe, Northern Asia, and the Arctic are the continents that seem to have the fastest speed in global warming. A reason for this is the changes in the ocean currents caused by the changes in winds and atmospheric circulation. Warm currents make land heat up faster when it reaches these areas (Mooney, 2019).



Figure 9b: A spring flood broke the pipes of the dam at Tromsa river, in 1985 (Photo: Sparby, K., 1985).

Temperature change 2021, compared with 1951-1980

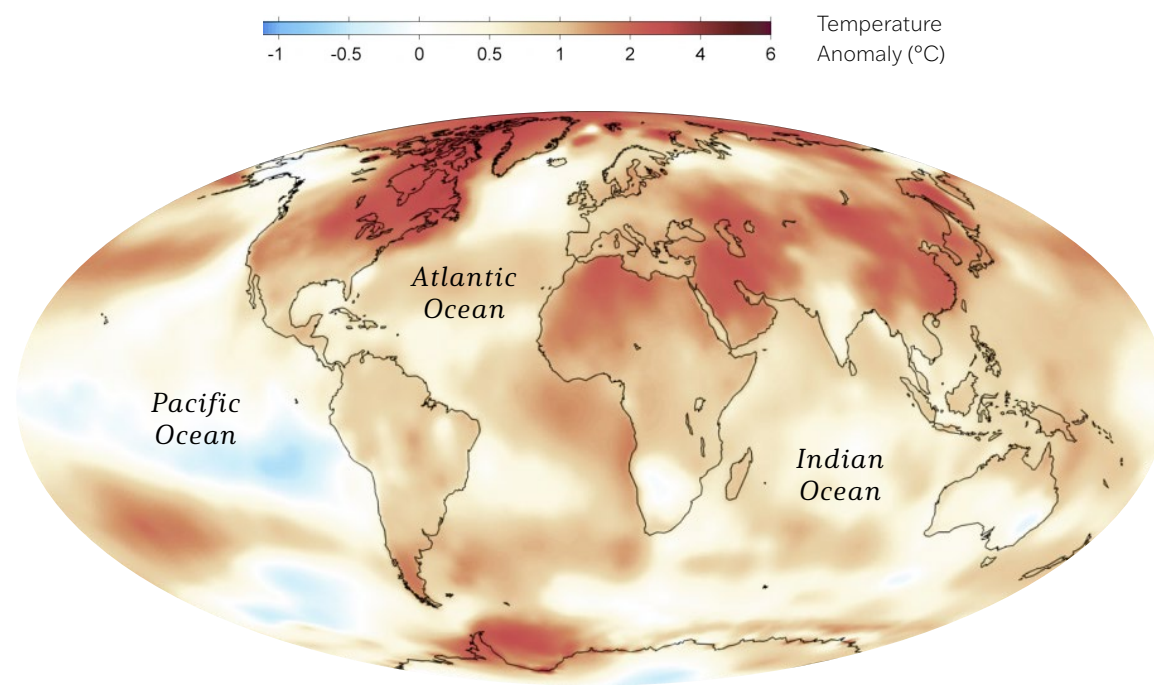

Figure 9a: Diagram based on the Global temperature report of 2021 (Map: Fjeldberg, I. 2022).

An increase in temperatures is not only damaging for the arctic glaciers, vulnerable waterways, and our human comfort. It favors invasive species that have not been a natural part of the ecosystems. Exotic warm-loving species settle where temperatures allow it, and out-concur species that have used to live in these areas threaten the existing ecology. With fewer local specialist species, biodiversity will become more monotonous and dominated by generalists (Nilsson et al., 2013). The rising sea level causes land degradation, and there will be less dry land to live on, and ecological habitats will disappear. Climate change also worsens land degradation by accelerating soil erosion due to more extreme weather. It does not only advocate for the dis-

tribution of invasive species but also pests and pathogens (IPBES, 2018). According to the IPBES report on land degradation (2018), together with climate change, the most common drivers for biodiversity loss are overexploitation, habitat loss /degradation, invasive species, and pollution. Changes in land use from natural ecosystems to agricultural systems also lead to land degradation, even though agriculture, for many, is seen as a natural green system (IPBES, 2018). In addition, climate affects water levels and the length of hydrological events. Therefore, maintaining healthy habitats in and around rivers is an essential part of our duty to help the earth mitigate climate change.



## Dam removal effects on biodiversity

Removing dams that have been in rivers for several years affects the ecology at the site where the dam is being removed. In addition, ecology, both upstreams from the dam and downstream, will be changed. What will change differ from each river, and some changes are not always visible before after years or decades. Some of the changes that might occur upstream after removal are the recolonization of fish. In addition, fish and other recolonizing organisms bring organic material and nutrients. This can increase productivity, increase colonizers' success, and facilitate suitable habitats for possible keystone species recolonizing upstream (Bellmore et al., 2019).

When removing the dam, the channel and floodplain will transform. Water levels may decrease at the dam site, and flow velocity increase. This affects pelagic organisms, such as plankton and lentic-adapted fish, that must adapt to a lotic environment. Changes in water levels and the settlement of new plants in riparian zones will also be a source of nutrients. Downstream sediments stored in the magazine will be deposited and affect the habitat structure. These sediments can dislocate benthic organisms such as algae, benthic animals, and fish eggs, as the sediments may scratch the existing sediments. In addition, the natural exchange of seeds and organic material from upstream will be re-established and positively affect the biology downstream (Bellmore et al., 2019).

For humans to change an ecosystem and transform, a site may not take much time. This can happen instantly. But for an ecosystem to recover alone can take a lot of time. For example, Hasselquist and colleagues found during their analysis that it takes at least a quarter century for the original diversity of species to return along rivers (Foss, 2015).



Figure 10: View from the Tromsa river (Photo: Fjeldberg, I. 2022).



# 2.6 National scale

Hydropower constitutes today 89% of the power production in Norway (Energifaktanorge, 2022). In most parts of the country, the landscape consists of high mountains with glaciers and deep valleys with rivers and fjords, which serve excellent opportunities for this type of energy production. The map below, in figure 11a, illustrates which countries in the world that has hydropower as their primary energy source, and Norway falls into this category.

Norway is one of the leading countries when it comes to hydropower production. In terms of the number of existing dams, Norway is not on the top but considering the density of dams and power produced, the country is on top of the list. The Norwegian government is the largest producer of hydropower in Europe and the 7th largest in the world.

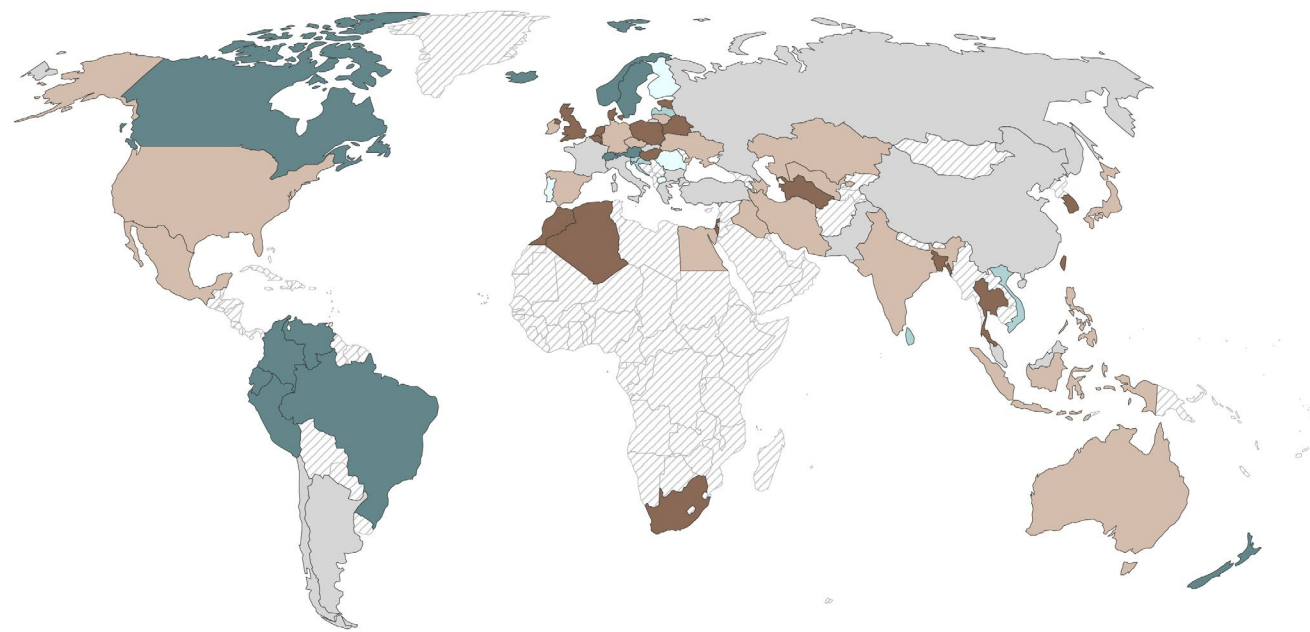
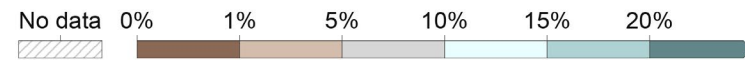

Figure 11a: Share of primary energy from hydroelectric power, 2021. Highest score indicate highest consumption of hydropower energy (map is modified. Based on source: Our world in data, 2022).



largest in the world, and 70% of Norway's most significant rivers are influenced by hydropower production (Klima- og miljødepartementet, 2015). Compared with other Scandinavian countries, energy production in Norway is almost entirely dominated by hydropower, as shown in the map in figure 11b.

The maps below (figure 11c and 11d) show both an overview of existing dams in general and existing hydropower plants in Norway. The information is presented in two separate maps, as the density of the dams makes the map hard to read when combined.

Figure 11b: Generation of electricity in the Nordic countries. Blue color represents hydropower as primary energy source (Image source: Nordregio, 2008).

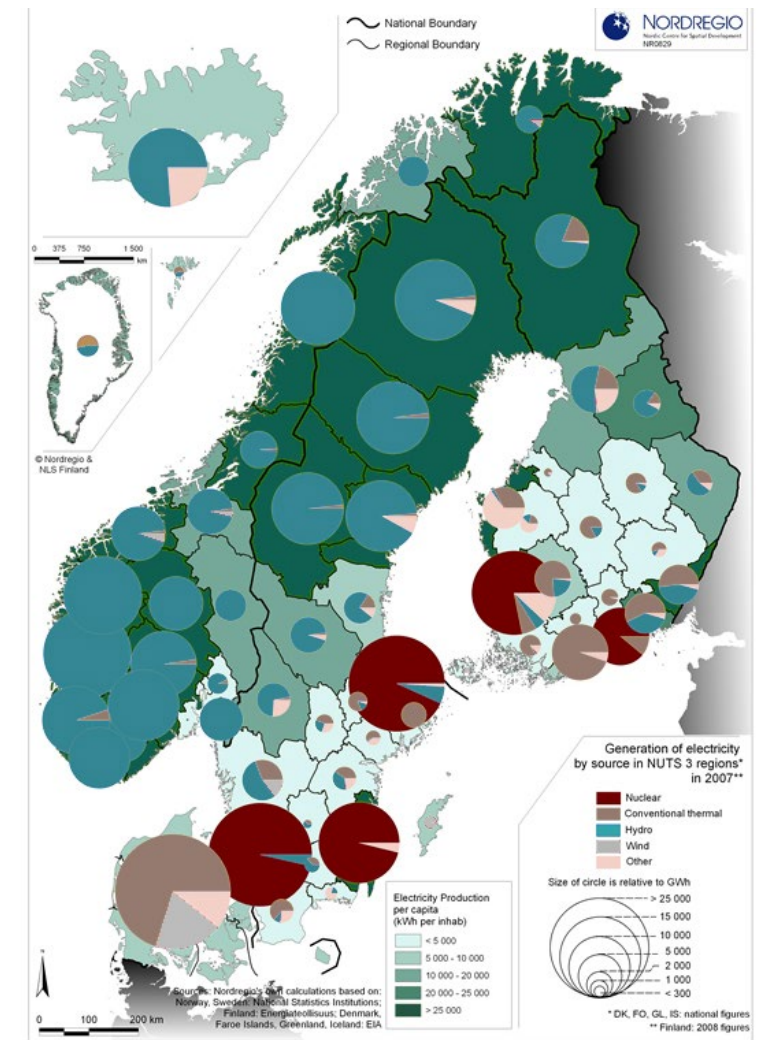
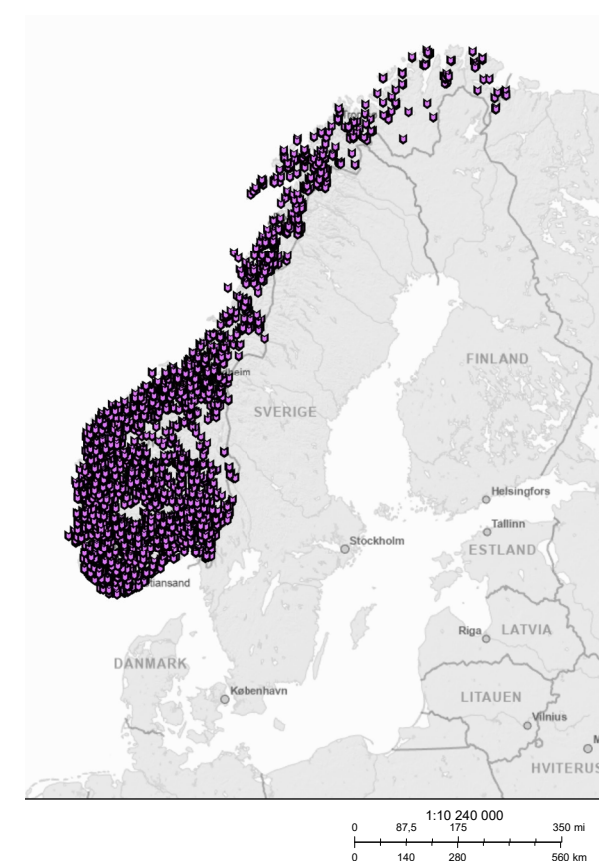
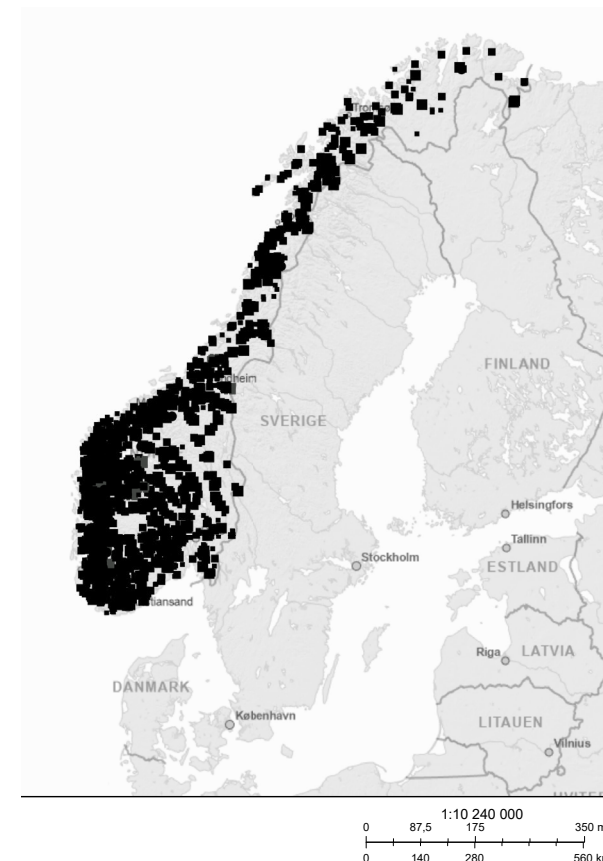

Figure 11c and 11d: left - overview of all dams in Norway. Right - all hydropower plants in Norway (Image source: NVE, 2022).



# How climate change will affect Norway

With its closeness to the Arctic, Norway's geographical position may have shielded the country from most of the visible physical changes in climate for a long time. But the results are becoming more visible also in the "cold north." The temperature in Norway is highly regulated by warm winds traveling with the gulf stream. If the gulf stream did not exist, and without the westerly wind belt, it is predicted that average temperatures in Norway would be 10-15 °C lower than today. The global rise in temperature more than compensates for the gulf stream's reduced heat (Bjerknessenteret, 2015). Being a country that typically has more than enough rain and snowfall during the seasons, it surprised many inhabitants when there recently was trouble with the lack of water due to climate changes. In Oslo and other parts of the country, the municipality even introduced water restrictions for the city's inhabitants from January to mid-summer (Drabløs, 2022). On the other hand, as the sea level rise is pressing in many parts of the world, it has not been as visible in Norway yet. One of the

reasons for this is that the elevation of the land is still rising from the last Ice age (Kartverket, 2021). The Norwegian Centre for Climate Services (NCCS), 2017, wrote a report with calculations for climate change effects on Norway by the year 2100. The main findings are as follows: Temperatures increase by around 4.5 °C, and heavy rainfall events will increase, be more intense, and occur more frequently. Floods caused by rainfall will occur more regularly, while floods caused by snowmelt will decrease in magnitude and frequency. Snow in lower land areas will become less abundant, and the number of glaciers will be reduced. Finally, the mean sea level will increase by 15 - 55 cm, depending on location (Hanssen-Bauer et al., 2017).

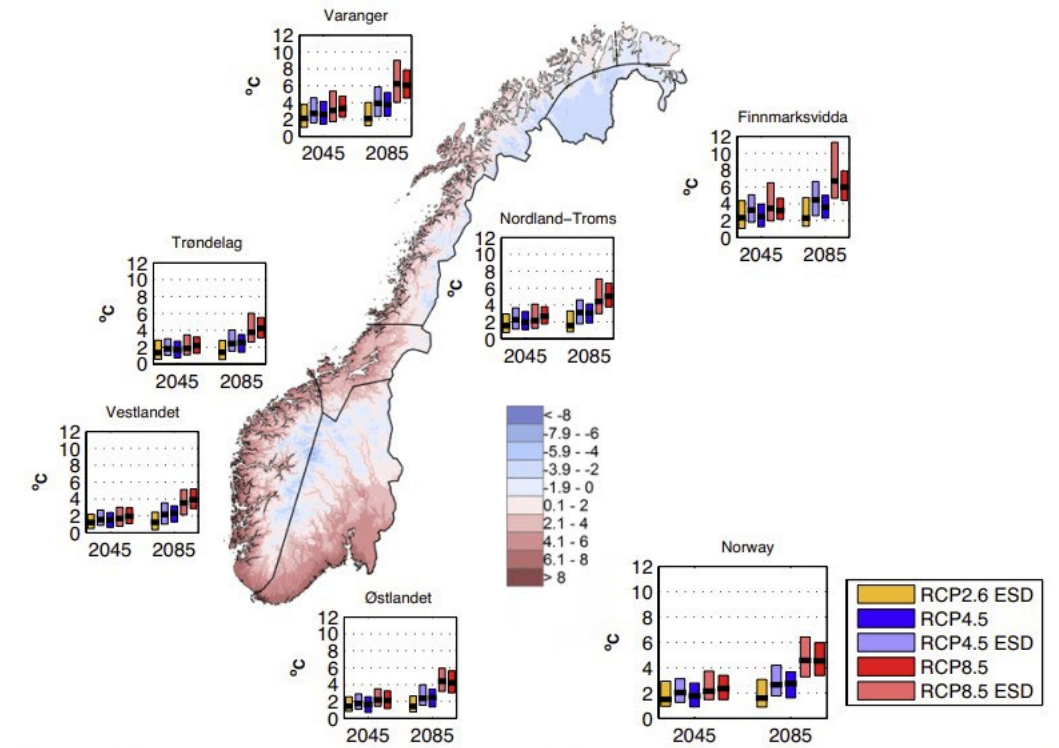

Figure 12b: Project change in annual temperature (celcius) from the period 1971-2000 to 2031-2060 ("2054" and 2071-2100 ("2085") for emission scenarios RCP2.6 (yellow), RCP4.5 (blue) and RCP8.5 (red) for different regions. ESD simulations are made for all scenarios; RCM simulations for RCP4.5 and RCP8.5. Median projections are indicated with a bold black line, while low and high projections are respectively lower and upper part of the boxes. The figure background map shows annual temperature (celcius) in the reference period 1971-2000, and boundaries between the different temperature regions are marked with black lines (Source for image and the caption: NCCS, 2015, p.20).

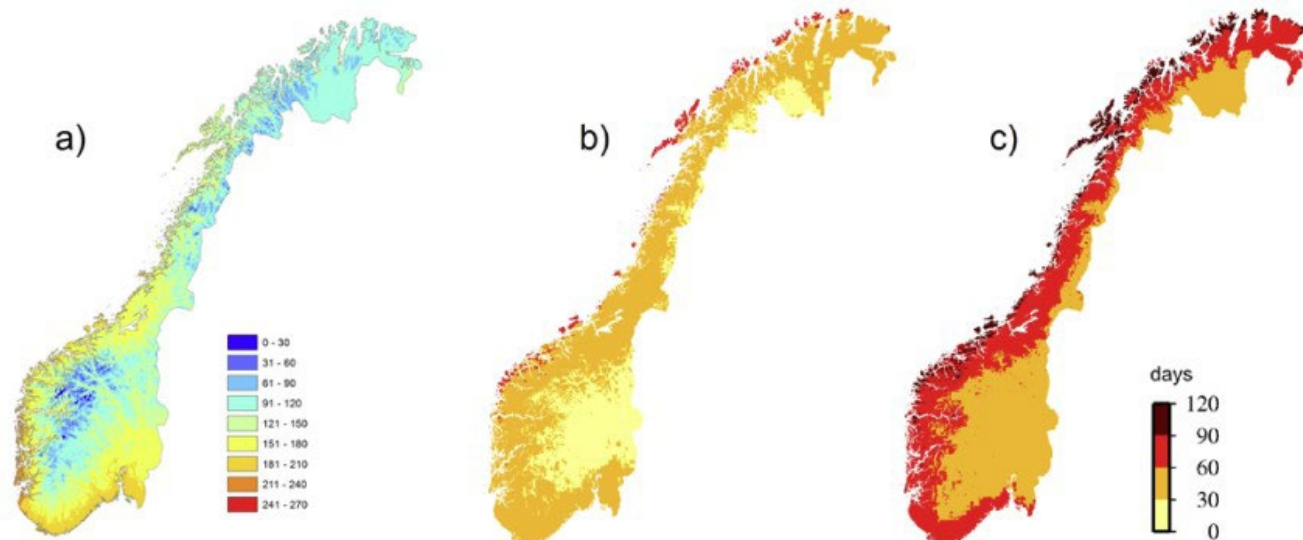

Figure 12a: Length of growing season (days) in the reference period 1971-2000 (a), and increase (days) in length of growing season from 1971-2000 to 2071-2100 for RCP4.5 (b) and RCP8.5 (c) (Source for image and the caption: NCCS, 2015, p.20).

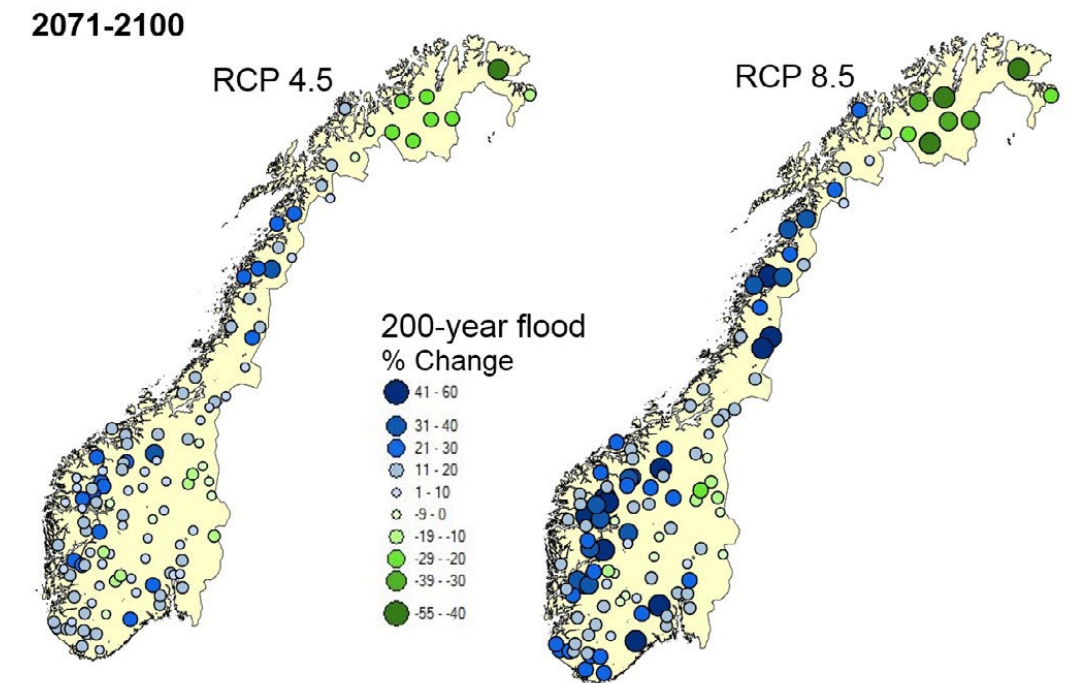

Figure 12c: Percentage change in the 200-year flood for medium (RCP4.5) and high (RCP8.5) emissions. Green indicates a reduction and blue an increase in flood magnitude (Source for image and the caption: NCCS, 2015, p.20).



## 2.7 Dam removal practice

There has been raised awareness of the Anthropocene as a new geological era we have entered, where humans have become dominant in changing and shaping biophysical processes in the world. We have become more aware of the challenges that have appeared due to our management. It is no longer sufficient only to reduce pollution in rivers to improve water quality and the quality of the environment. It has become necessary to consider the very structure of the aquatic environment to re-establish and rehabilitate it (Sneddon et al., 2017).

Removing dams and barriers in rivers has become more common in later years. American rivers, an environmental group based in the USA, started up a campaign for dam removal in the 1990s (Sneddon et al., 2017). Since then, the interest in dam removal projects has increased, and the year 2021 broke the record of dams removed in Europe in a year (Green, 2022).

Dam removal is a global trend that has grown stronger roots as we have seen this procedure's positive effects on the ecosystems of our rivers. However, the knowledge of the distribution of international dam removal may be misleading as the information about these projects is sometimes geographically restricted and restricted by the species researched. A study by Ding et al., 2018 revealed that most dam removal projects have occurred in North America and Europe (Ding et al., 2018).

Dam Removal Europe, World Fish Migration Foundation, WWF, and the European Investment Bank are hosting an annual award to celebrate the most inspiring and innovative barrier removals in the European rivers. The Dutch Postcode Lottery also supports the award (Dam Removal Europe, 2022a).



Figure 13: Removal of the Tikkurila dam in Finland (Photo: Pyry Kantonen Photography, 2019).

## Process

There are different methods of removing dams, and the procedure is chosen by what best fits the river and the dam that should be removed. The landscape and material of the construction are things that will impact the decision. Barriers can be removed "in the dry," which means that the waterway will be redirected from the removal site while the work is carried out. This way, no machines or contaminants from the machines will be in contact with the water during the removal. Or it can be removed "in the wet" during a selected time of the year that is better to conduct the removal at the particular site, considering the water levels and other matters such as biological activity in the area. For more minor barriers, the removal may happen by voluntary work and may take only hours or some days. But for dams with walls, it is often necessary to use larger machines to remove or use dynamite. Dynamite is rarely used for removal, but in some cases, it is necessary to demolish the structure. The removal can happen continuously until the dam is entirely removed, but it can also be carried out in stages over time to adapt better to natural processes (American Rivers, no date).

## Law in Norway

The law of regulation and construction of hydropower facilities in waterways, § 10. Closure of facilities, first paragraph: "If the government does not want to take over a regulation of a transmission facility at the end of the license period, nor is a new regulation license granted, the owner is obliged to remove the facility within a deadline set by the ministry, following an order from the ministry" (Vassdragsreguleringsloven, 1917). If no one is willing to pay for maintenance regardless of whether the dam is in function or decommissioned, then the dam shall be removed by the owner, and the site returned to its original state. Maintenance of a dam is often expensive, but in some cases, the municipality is willing to cover the costs. This can happen, for example, if the dam has created recreational benefits or has become of significant importance to a species of national interest to preserve (Vannressursloven, 2001b).



## 2.8 Restoration for sustainable development of the world

The UN Sustainable Development goal number 15 directly points out the importance of conserving biodiversity, preventing species loss, and preventing land degradation (United Nations, no date-e). Restoration of rivers and terrestrial ecosystems, seen from a global perspective, also supports the natural cycles of the Earth, such as water-, carbon-, and nitrogen cycles (Keesstra et al., 2018). And using Nature Based Solutions (NBS), renaturalization while mimicking nature, and letting nature continue the process seems to have given good results when implemented. Keesstra et al., 2018 frame it as follows: *“Restoration and rehabilitation strategies that are based on natural processes and cycles are sustainable as they use natural flows of matter and energy, take advantage of local solutions and follow the seasonal and temporal changes of the ecosystems”* (Keesstra et al., 2018).

As mentioned in the chapter Ecological connectivity (p. 22), the riparian zones provide multiple ecological functions, including the refuge of biodiversity, flood buffering, water and nutrient filtering, shading, and climate regulation. This is directly linked to essential ecosystem services, which also have direct economic relevance, such as maintaining flood control and support for agriculture, forestry, urbanization, and recreational activities (González et al., 2017). Therefore restoration of riparian zones, along with the river itself, is an essential part of sustainable environmental development. And for these zones to be maintained vital, there has to be water in the river, and vice versa.

The way the climate changes are evolving, wetland vegetation may be an essential tool for future land development. For example, the Yolo Bypass in California, United States, conveys 80% of Sacramento River floodwaters during large events, handling the stormwater from the city. And the 24 000-ha floodplains can convey more than three times the total flood control storage volume in all Sacramento basin reservoirs, which is around 12.5 billion cubic meters of water (Opperman et al., 2009).

Removing dams near an estuary may have another unpredicted positive effect on river deltas. For example, a study done by Warrick et al., 2019 on the project of removal of the dam at the Elwha River Delta in Washington, United States, revealed that the sedimentation waves of the river delta became less prominent with distance and time and resulted in an extension of the shoreline, thus reversing coastal erosion (Warrick et al., 2019).

With the water in rivers decreasing, and at the same time, massive flood events occur, we have an essential job of maintaining and re-establishing the water in our rivers to prevent unnecessary fatal consequences. And by doing so, we may even add additional positive environments for the stakeholders. In a case study of the restoration of the Isar river, Pugliese et al., 2020 addressed that the applied Nature-based approach was the most advisable solution when compared with the “grey” scenario of canalization that had dominated the Isar river running throughout the city of Munich until the restoration work was completed in 2013. The highest score was retrieved for the environmental and social benefits, whereas risk reduction, technical and local economy reached comparable results. Furthermore, the solution provided a higher quality of life for the stakeholders, enhanced biodiversity, strengthened the ecosystem, and improved the visual perception of the landscape (Pugliese et al., 2020).



Figure 14: In the Tromsa river (Photo: Fjeldberg, I. 2022).



## 2.9 Relation between society and the green environment

The need for a natural system to recover and what humans enjoy do not necessarily correlate. For example, when staying "out in the wild" in a national park or a forest, people may appreciate the wilderness of free-growing trees, shrubs, and mixed floral vegetation. However, such wild growing environments can be perceived as untidy in urban areas, making people feel unsafe if the vegetation is not nurtured and maintained (Nassauer, 1995). This has to do with people's perceptions of nature based on several factors. A study was done on social perception and ecological value by Arsênio et al., 2020. They found that both personal experiences and cultural background affect our perception of ecological conditions. Therefore it is crucial to know the stakeholders of a site when proposing changes to it. A site will more likely be used and maintained if the users embrace it (Arsênio et al., 2020).

In addition, there will always be some level of attachment to a place where someone has been growing up and has created memories. Therefore, changes to this place may be harder to accept than at a site without emotional attachments. What seems universal regarding how we relate to nature is that people, to some degree, seem to be attracted to water. Regardless of their background, most people enjoy being around water for recreation, relaxation, and several cultures and indigenous groups have religious beliefs and rituals connected to water features (International Rivers et al., 2020).

### Social reaction to dams

Jørgensen (2017) summarizes and defines how we portray nature from two ways of thinking: nature-culture dichotomy and nature-culture (Jørgensen, 2017). The nature-culture dichotomy sees man-made constructions and technology as disturbances to wildlife and that a site is never natural as long as there is a presence of, for example, a human-constructed dam. The ones sharing this view often present it as the "right way," based on ecological science. In contrast, the nature-culture individuals see the site around the dam as nature because of the fact that there are water, trees, and ecological processes present. This new nature that has developed during the decades of the dam's presence has become part of the stakeholder's everyday life and what they know and care about. The dam has become integrated into both an ecological and cultural system (Jørgensen, 2017). Therefore, we cannot expect to receive any wanted response from different stakeholders of a site when proposing changes without involving them. Ideally, every voice should be heard and taken into account in advance.

Furthermore, there seems to be a shift in the mindset on developing our environment: Ongoing climate changes may have affected how people relate to and perceive threats to nature. Restoration and renaturalization projects using nature-based solutions (NBS) seem to have become more easily accepted after reports of degraded nature locally and globally (IPBES, 2019). Poff and Mathews stated, "*What seems clear is that environmental flows is now expanding and transitioning from an era of aquatic conservation and ecological integrity to a period of explicit 'social-ecological sustainability'*" (Poff & Matthews, 2013, p. 671) in their article. We seem to focus more on integrating ecology into social and urban areas and creating levels of symbiosis rather than separation.

### Peoples wellness

Spending time outdoors in nature has proven to promote physical and psychological health. Nature provides opportunities to be physically active by exercising or doing other recreational activities. When spending time outdoors, there is also a chance to stumble upon people or to arrange with people to meet to be social. Social contact is essential for human wellness and positively affects stress. People also seek to spend time in nature to relax and escape everyday urban life; it may work as a form of meditation and has even proven to be a therapeutic tool (Thompson, 2015). Newer studies have also found that microbiota gathered from the

environment and animals are essential for human wellness to maintain a well-functioning immune system and prevent autoimmune diseases. Autoimmune diseases have become more common in our modern times, which can be linked to urban environments with a lot of time spent indoors, sometimes slight variation in diet, and minimal exposure to animals, plants, and soil that holds microorganisms (Douglas et al., 2021). Therefore the ability to spend time in nature seems not to be a luxury but a necessity.



## 2.10 Reference projects of dam removal and re-naturalization



Figure 15a: Parts of the riverscape in the river Tikurila, Finland, after dam removal (Photo: Pyy Kantonen Photography, 2019).



# Tikkurila Dam, Finland

Dam removal Europe and Loci Landscape Architecture, Finland

Until 2019 the river running through the city of Vantaa was split by a concrete dam. Measurements of the dam were 4,5m high, 3m wide, and 47m long. The dam was created to serve a mill in the middle ages, and later it was rebuilt with concrete in 1912 to generate power for a linseed factory. The dam has not been in use for many years, and even though a fish ladder was installed in 1994, the dam was a barrier to migratory fish. Today the dam has been partly removed, with a length of approximately 10 meters on each side still standing, for cultural value (Dam Removal Europe, 2019).



Figure 15b: Parts of the riverscape have wider riparian zones with vibrant vegetation (Photo: Pyy Kantonen Photography, 2019).

Figure 15c: Masterplan for the project area (Image source: Loci Landscape Architects Finland, no date).



Figure 15d: Trails alongside the riverside (Photo: Pyy Kantonen Photography, 2019).

Figure 15e: Spots are used as habitats for people and humans (Photo: Pyy Kantonen Photography, 2019).



Figure 15f: Parts of the dam is preserved and included in the design as a cultural monument (Photo: Pyy Kantonen Photography, 2019).

Figure 15g: Places for people to be in contact with the water (Photo: Pyy Kantonen Photography, 2019).

During the planning phase, contaminated soils were discovered upstream from the dam. The solution was to remove some contaminated soil and cover up parts with clean soil. Engineers mapped out geotechnical solutions for erosion control of the banks. River restoration design was implemented in the new channel bed in the part of the river most affected by the removal. Vegetation was designed in the sub-channel area, and on the south shore, a path was created for anglers. After the central part of the dam was removed in 2019, trout were observed spawning further up in the river, which was the project's goal (Dam Removal Europe, 2019). Loci Landscape architecture won the competition for restoration in 2016. Later they followed up with

designing a masterplan for the riverside. In the design of the restored river and riverside, the landscape architects intertwined history and nature by using materials that refer to the industrial history at the site. The architects used Outdoor tiles, Corten steel, and reddish-brown colors in the design on the banks of the rapids. In the western parts of the river, the design has a more natural and organic touch, and they wanted to preserve as much vegetation as possible. As a result of this restoration, the river is again home to trout, thick-shelled river mussels, otters, and other animals (Vesikansa, 2022).



# Rattlesnake Dam, Montana, USA

City of Missoula

This dam was built as a water reservoir until the spring of 2020, when the removal project started. It was constructed in 1904 and was an important part of the water supply for the city of Missoula until 1983. However, due to concerns about the drinking water, the facility was no longer used as a water source after 1983. Eventually, it was decided to remove the dam since it was only a hazard to its surroundings and the community (FEMA, 2020). In addition, Rattlesnake Creek is one of the major sources of trout to the Clark Fork river and is a popular recreation destination (Engage Missoula, 2021).

Project benefits:

- "Restore habitat for native and threatened fish species and wildlife.
- Enhance the recreational corridor between Missoula urban area and Rattlesnake Wilderness.
- Renaturalize the site to improve stream, floodplain, and riparian benefits.
- Minimize or eliminate safety and liability hazards on site.
- Reduce maintenance and operation costs to Missoula Water."

(Engage Missoula, 2021)

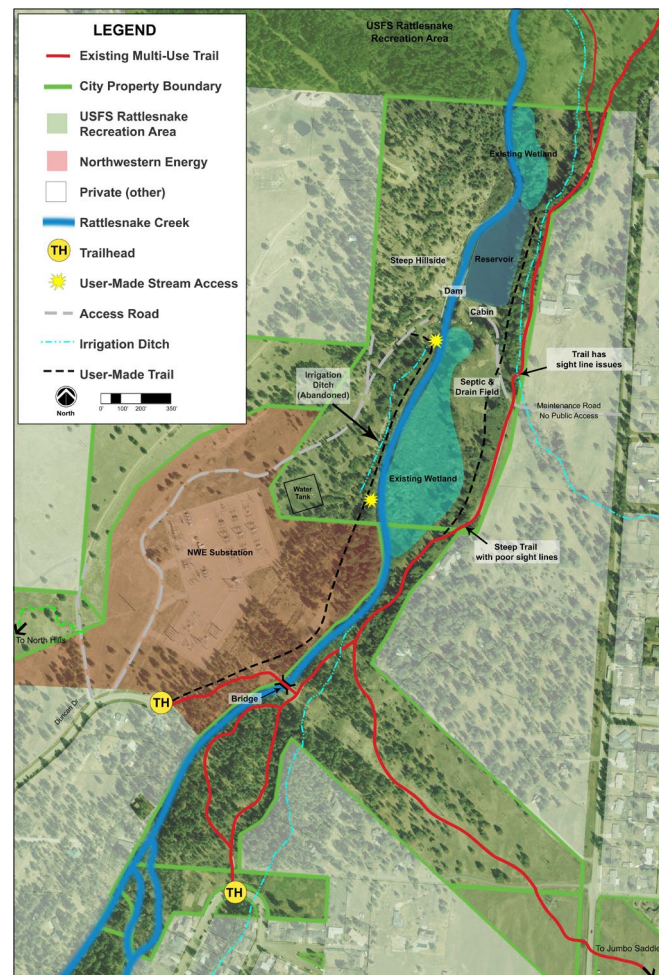

Figure #1 DRAFT Rattlesnake Greenbelt Existing Conditions February 2019

They have come far in the planning process, and the completed steps are conceptual design, public view, final design, and construction design. They are now in the revegetation phase. Seed mixes were used in the vegetation phase, and they maintained the site by manually watering and weeding. What remains is the development of recreational trails and project monitoring. In the end, the vegetation around the creek is predicted to consist of local rare wetland vegetation, native riparian forest, and natural streambank (Engage Missoula, 2021).

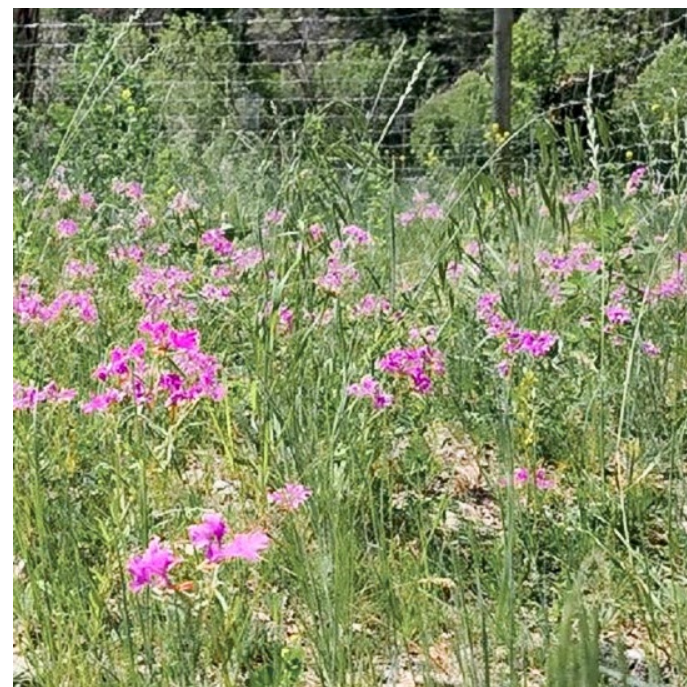

Figure 16b: Blooming Clarikia from our seed mix (Photo: Eisenhand, T., no date).



Figure 16c: The site before removal of the dam (Image source: City of Missoula, 2018).



Figure 16d: Creek Excavation Starting to Wrap up (Image source: City of Missoula, no date).



Figure 16e: Former Dam Site Ready for Revegetation (Image source: City of Missoula, no date).



# Restoration of Måna river, Telemark, Norway

Hydro energi and Økogrønt AS. Roland Heibl

This is a rehabilitation project of the river Måna, located in Tinn municipality, east of Telemark county. The river was highly affected by changes in the watercourse due to several dams for hydropower production. In addition, four kilometers of the river were channelized at the outlet of the river. Some of the main aims of this project were to rehabilitate ecological dynamics and to recruit trout from lake Tinnsjøen where the river has its outlet. Another objective is to increase the recreational value along the river (Heggenes & Sageie, 2006).

In this project, no dams were removed. Instead, they have relocated rocks and sediments to create variation, steer the movement of the water, and decrease the water release to the groundwater table. They have constructed thresholds, bow-formations, groups of rocks, sediment magazines, and revegetated the riverbanks. A recreational track was improved as well (Heibl, 2022). The illustration below shows the design of one part of the river. The sketch below gives input on their thinking when designing and placing more

giant rocks in the river. Great forces of the water and currents may move even massive rocks around if they are not placed appropriately into the riverbed.

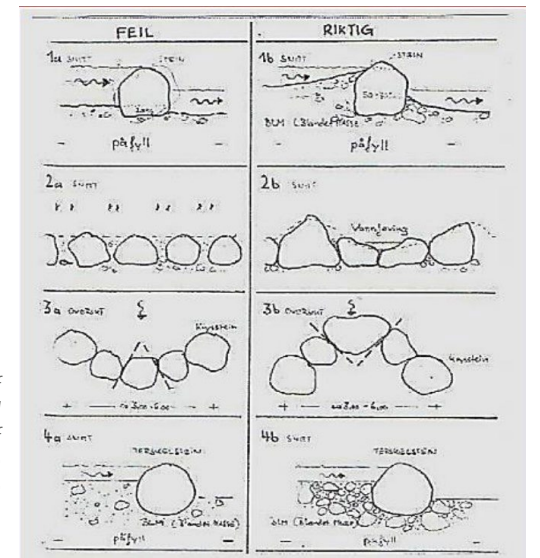

Figure 17d: Sketch of technical placement of rocks in the riverbed (Image source: Økogrønt, 2022).



Figure 17a and 17b: To the right, the photo shows the river before the restoration, while the image to the left shows the same site after the restoration (Image source: Økogrønt, 2022).



Figure 17c: A section of the plan for the restoration (Image source: Økogrønt, 2022).



Figure 17e and 17f: For large machines to cross the river, they designed a threshold functioning as a road (Image source: Økogrønt, 2022).

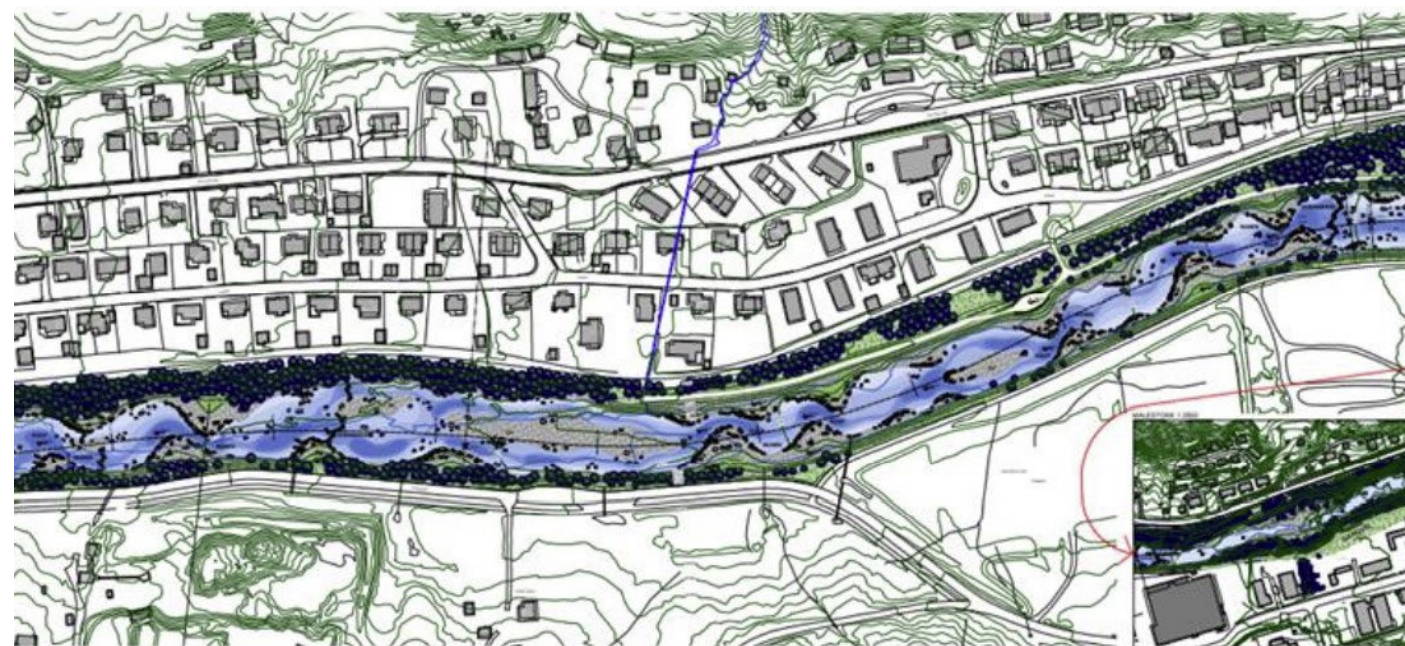

Figure 17g: The beach constructed at the riverside has been a popular facility welcomed by the locals (Image source: Økogrønt, 2022).





# Takes from the projects

The Tikkurila site is an urban space with the river as a natural element running through the city. Therefore, for this project, it was natural to have urban features implemented with nature. Moreover, in this project, the remains of the dam are working as a historical element, which has cultural value. This lets people remember how the site was used before the removal of the dam and may strengthen the attachment to the new design. The designed river sides have trails, jetties, and rest areas connecting people to the water.

At Rattlesnake Creek, the surroundings are rural and wild. There are no urban elements at the site, and the creek looks natural. After the removal and reconstruction, the vegetation was boosted by planting and maintenance. Even though the area is rural, the recreational track design is important here, allowing people to use nature.

The restoration project of Måna elveleie is different from the other projects, as no dam was removed from this river. However, it is fascinating to see how much difference it can make by moving around on rocks to steer the water courses and lift the water table. What all of the mentioned projects have in common is that they all aim to renaturalize the sites.

Inspiration I have taken from these projects is, for example, how it is possible to transform riversides in urban areas to become full of life. And also how renaturalization in both urban and remote sites can genuinely benefit the species living there. In addition, the projects have examples of different uses for the stakeholders in terms of recreational opportunities that seem to work well without disrupting the ecology too much.



Figure 18: Image from the river in Tikkurila after restoration (Photo: Pyy Kantonen photography, 2019).



# 2.11 Methodology

*Landscape identity, removal of dam and consequences*

*Ecology, cooperate with nature*

*Landscape identity, cooperating with nature*

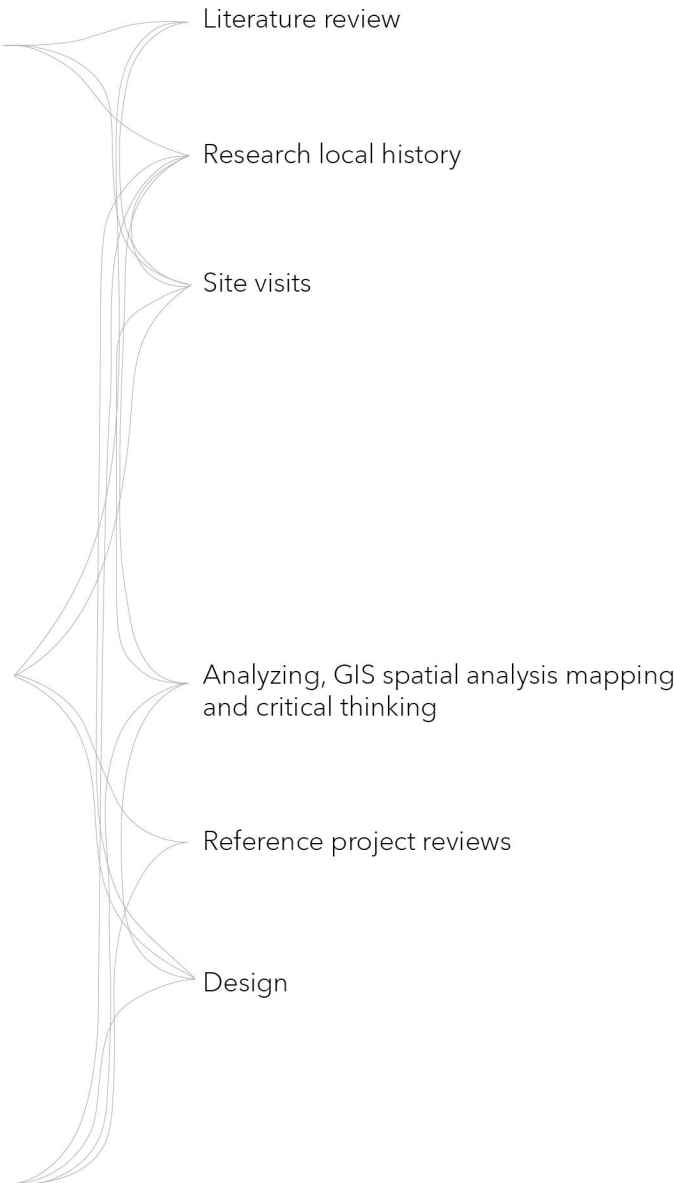

In the work of this thesis, research was done in several ways before ending up with the proposed plan. The research consists of reading relevant material, such as scientific articles, Landscape architecture texts, and academic material pertinent to the project. In addition, the site was visited several times to get a realistic impression of the area. Reading local history and sporadic conversations with people living there was also a part of the research. Parallel to this, methods such as mapping with GIS were used, working at different scales and critical thinking using the information that was actively gathered. I have used a combination of different methods and sources, pulled out techniques learned in previous courses, and applied what would be relevant to this study. The diagram (figure 19a) shows that the design was developed by going back and forth between the stages. Reference projects found relevant to this project were reviewed as inspiration. The work was started by familiarising myself with the site, situation, and consequences of what had happened. First, it was a matter of establishing an understanding of the site's identity and the consequences of the dam removal. Next, research steered the project to an angle of cooperating with nature, and through the work combined, the proposal builds a new identity of the landscape and takes the land areas back, asking us to cooperate with nature.

## Delimitation

I present the most relevant global topics early in the thesis before I zoom in on Norway and, later, the Lågen river and the project area at the Tromsa river. The geographic limitations of the project area are limited to the dam's site in the Tromsa river and include riparian zones to the outlet into the Lågen river. I have also included riparian zones of the Lågen river at the outlet of Tromsa, as this part is also vital to Tromsa. I have included broader geographical scales in the analysis to establish a solid understanding.

The proposal is focused on restoring the area south of the Tromsnesvegen bridge because that is where the flood zone affects the landscape beyond the river and riverbanks. Due to infrastructure, space is also limited between this bridge and the forest vegetation leading to the dam site, leaving little room for the expansion of riparian zones. But a suggestion on how to prevent erosion is presented for the dam site area. I have given suggestions through a series of conceptual drawings for use by the stakeholders. It is indicated where they might be implemented, but they are not geographically restricted.

Figure 19a: Methodology and process (diagram: Fjeldberg, I., 2022).





Figure 19b: the dam site, Tromsø, with vibrant colors (Photo: Fjeldberg, I., 2022).

### 3. River Lågen and the township of Fåvang



# Lågen and the impact of dam construction

Lågen is the largest supply river connected to Mjøsa. The river begins at Lesjaskogsvatnet at 611 m asl. and ends in Mjøsa lake (123,2-119,6 m asl.) Along the way, the water streams through a varying landscape where the river is wide and slow running in some places. In other parts, the river landscape is influenced by canyons, steeper hills, narrow water surfaces with more turbulence, and movement (Thorsnæs, 2022). At Fåvang township, the river is home to several fish species, such as trout (*Salmo trutta*), perch (*Perca fluviatilis*), grayling (*Thymallus thymallus*), and cyprinids (*Cyprinidae*). Unfortunately, the construction of hydropower dams, sediment extraction, building and canalization, and infrastructure construction have decreased the occurrence of critical spawning areas and habitats for fish (Johnsen et al., 2021). Much of the land use around Lågen consists of agricultural fields, which have resulted in unnatural phosphorus outlets into the river throughout the years. Nevertheless, the river is classified with moderate to good ecological health according to an investigation by NIBIO (Bechmann et al., 2021).



Figure 20: Location map and catchment area of Lågen and the river network (map: Fjeldberg, I. 2022).





Figure 21a: Harpefoss hydropower dam (Photo: Hafslund Eco Vannkraft).



Figure 21b: Hunderfossen hydropower dam (Photo: Hafslund Eco Vannkraft).

Several hydropower dams restrict Lågen and some of the connected rivers from full river connectivity. As shown in the map (figure 21c.), the Hunderfossen power plant in the south and Harpefoss in the north create the borders for the part of Lågen that limits free river connectivity. At Hunderfossen dam, they have made a fish ladder, where most bigger fish can pass, but Harpefoss is an absolute ecological and morphological barrier.

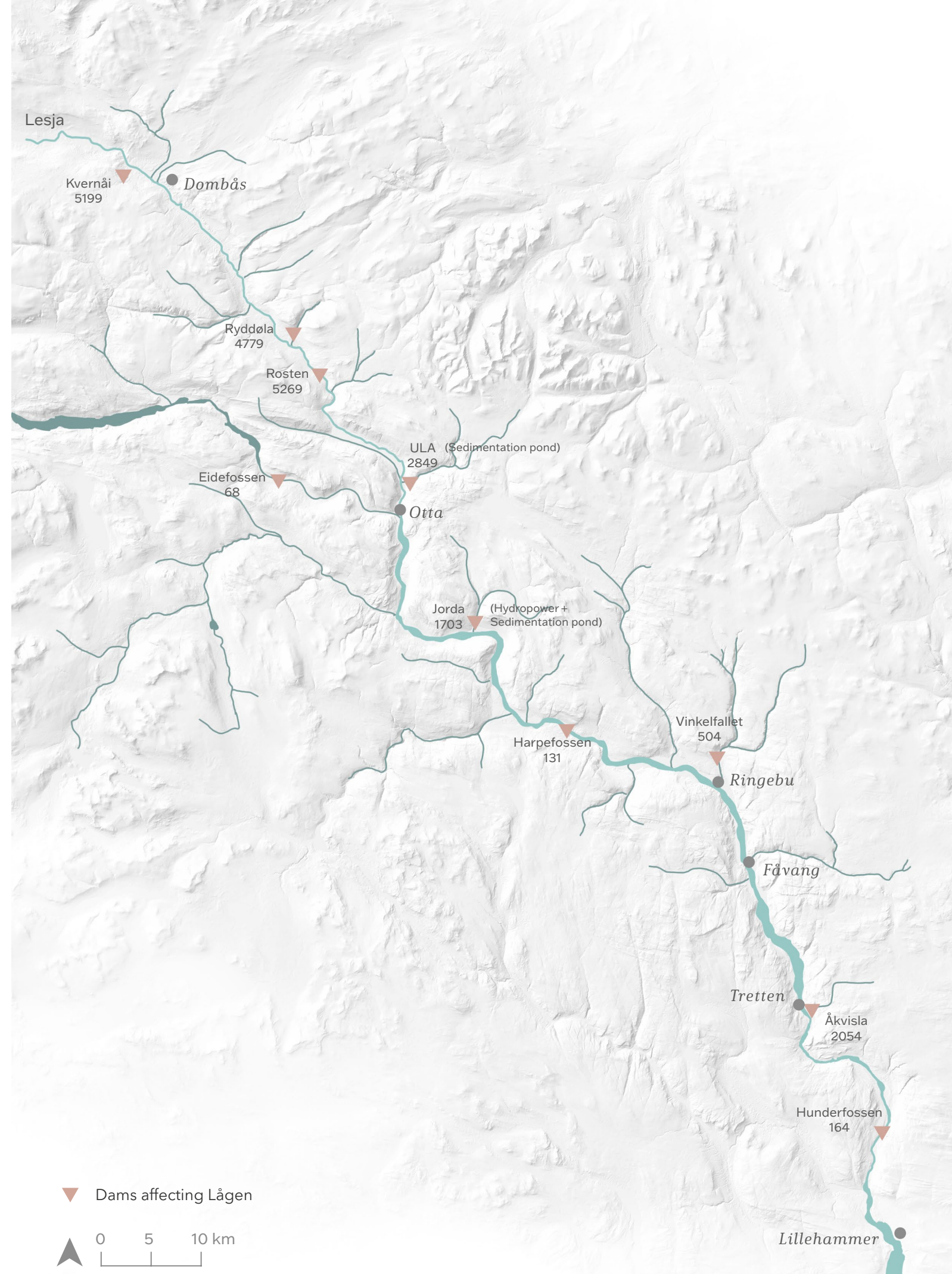

Figure 21c: Lågen river with tributaries and dams (map: Fjeldberg, I. 2022).





Figure 21d: Thresholds constructed in the Tromsa river after the removal of the dam (Photo: Fjeldberg, I. 2022).

# Part 4. Project area



# 4.1 Project area River Tromsa



Figure 22a: Location Fåvang (Map: Fjeldberg, I. 2022).

## Location

Fåvang is a small village in Ringebru in the Gudbrandsdalen valley, located on the eastern side of Lågen, with around 720 inhabitants as of the year 2021 (SSB, 2021). River Tromsa runs through the village from east to west and has been important for the town since the settlement.

## River Tromsa

Tromsa runs from Gopollfjellet in Ringebru municipality and down to Fåvang, where the river outlet flows into Lågen. Tromsa is estimated to be 34,3 km long, has a catchment area of 322 km<sup>2</sup> (NVE, 2022a), and is located at 1350 - 183 m asl. (NVE, 2009). Until January 2022, a dam was located in the river in the village of Fåvang. It was partially removed on behalf of a local fishing organization to restore connectivity for trout and grayling.

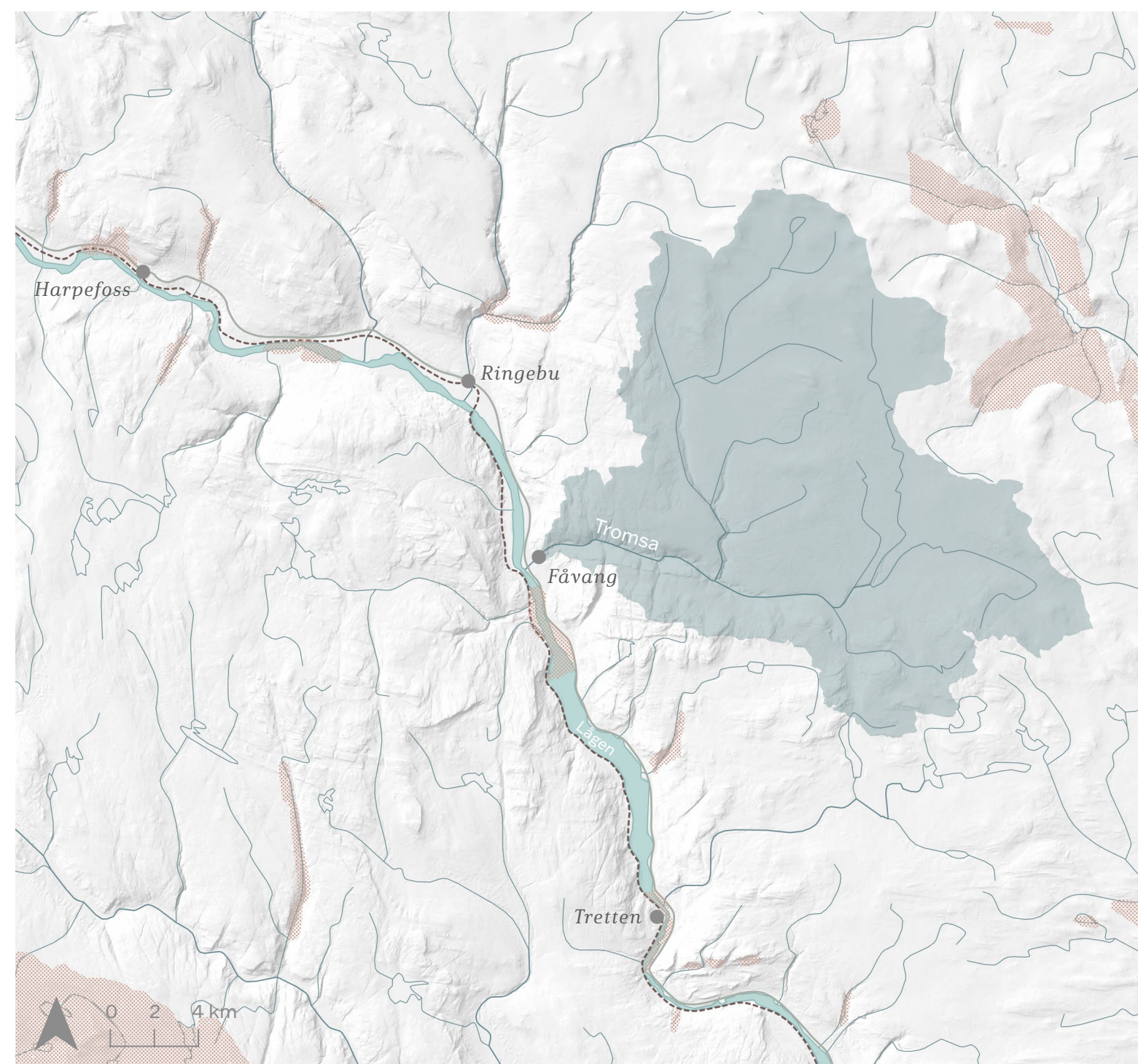

Figure 22b: Catchment area of Tromsa, and nature conservation areas. Map Scale 1:250 000 (Map: Fjeldberg, I. 2022).

- Catchment area - Tromsa
- Nature conservation
- Railway
- E6

The river Tromsa and connected rivers and streams are protected by the Verneplan IV of 1993, named Tromsa, ID 002/5 (NVEb, 2021). The catchment area of Tromsa implies the protected area's outline and is shown in figure 22b. Reasons for the conservation of the site are the river's characteristics, connected peatland, and that the site is a part of central parts of a characteristic and attractive landscape that contains mountain ranges combined with valleys with canyons and steep, narrow ravines. In addition, the shape of the rivers, flora, land fauna, and water fauna are all criteria for the conservation status (NVEb, 2021).



# Land cover Gudbrandsdalen valley

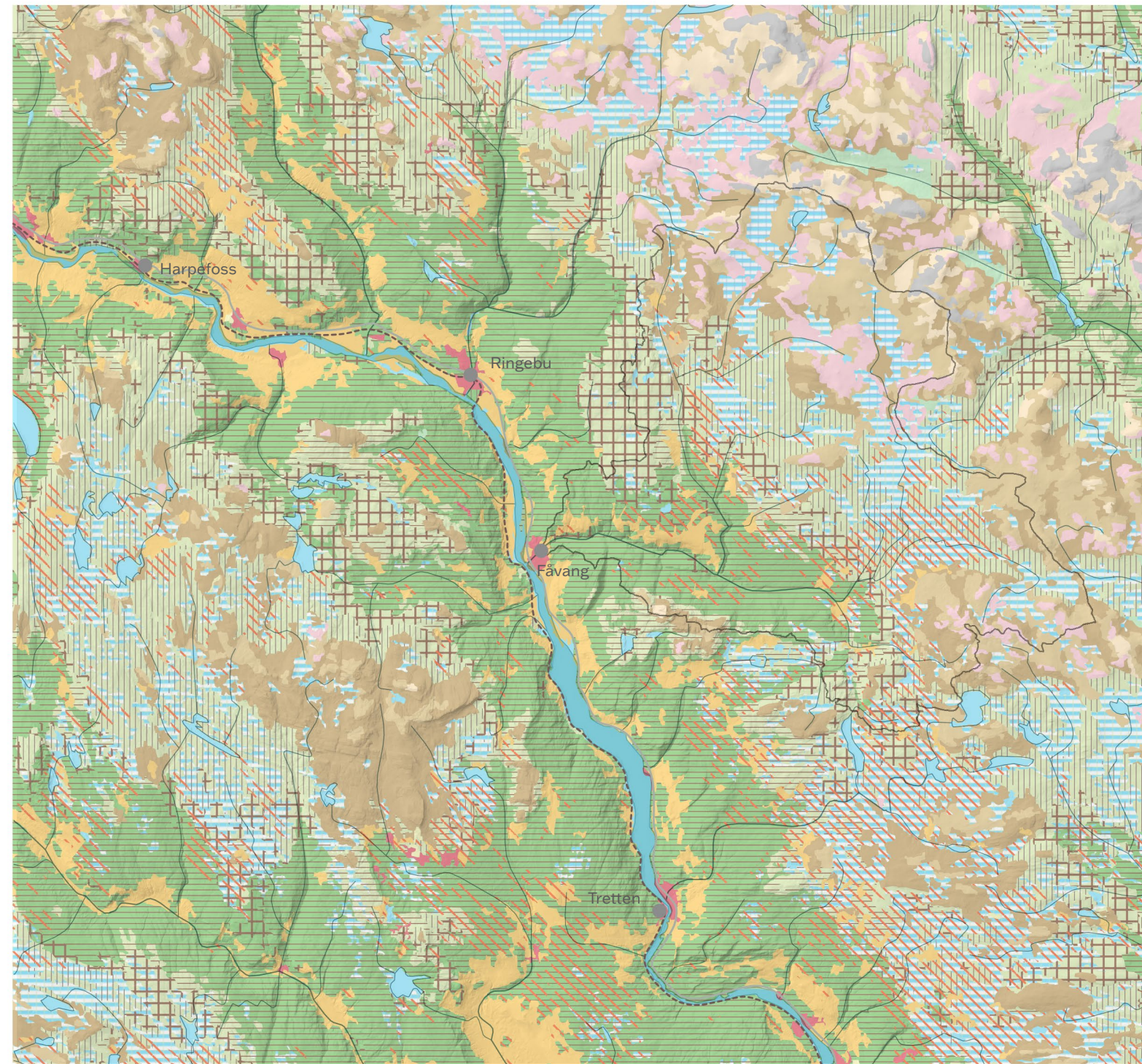

- Fresh vegetation
- connected dry - medium dry vegetation
- low covered ground
- patchy and sparse vegetation
- ground not covered by vegetation
- no registered vegetation cover
- ▨ arable land
- ▨ coniferous forest
- ▨ deciduous forest
- ▨ mixed forest
- ▨ swamp
- produktiv forest
- not produktiv forest
- no registered productivity class
- agricultural land
- forest
- Housing and infrastructure
- clacier
- fresh water

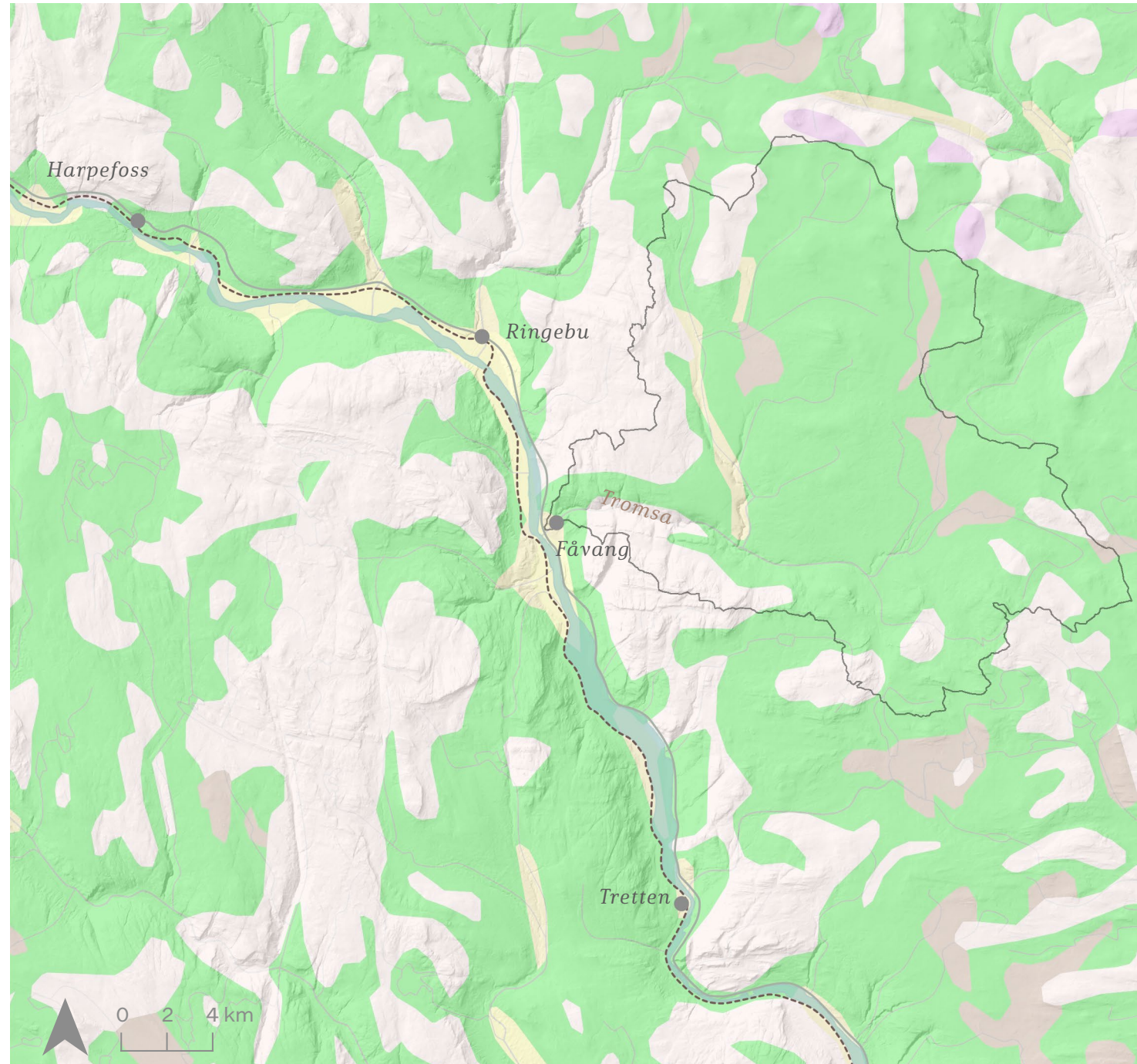

Figure 23: Landcover, Gudbrandsdalen.  
Scale 1:250 000 (Map: Fjeldberg, I. 2022).

In the closest proximity to the river Lågen, the landscape is dominated by agriculture, which separates the forest vegetation from the riversides at most sites.



# Geology



- Moraine material, thick cover
- Glacial rivers and glacial lakes
- Deposits from rivers and streams
- Turf and peat (organic material)
- Bare mountain and mountain with thin cover
- Ocean rock (Blokkhav)

Figure 24a: Soil, loose material map (Map: Fjeldberg, I. 2022).



Figure 24b: Geology at the dam site (Photo: Fjeldberg, I. 2022).

As shown in figure 24a, the Gudbrandsdalen valley has geology consisting of great areas with hard bedrock, thick moraine and glacial deposits in the valley floor, and organic geological material from turf in the mountain areas. The geology of the protected area, lower Tromsa, consists of shale and sandstone in the northern parts. In the south, the bedrock is more complex, including elements of limestone and slate. The site referred to in this thesis is located below the marine border from the ice age (NOU 1991: 12B).



# Nature risks

No episodes of avalanches are registered near Fåvang town center. Still, there are potential risks of snow avalanches and landslides, especially in the landscape of the steep canyons of the Tromsa river. The floods in Gudbrandsdalen valley can be severe, as Lågen meanders in the terrain of flat topology at many parts of the valley. Significant areas of Fåvang have been flooded several times. In figure 32 on page 84, the most considerable floods are mentioned. As of the last massive flood in 1995, significant land areas were underwater, and not many years later, new spring floods applied damage and costs to industry and private houses (GD, 2016). Figure 25c shows the zone of floods that is predicted to happen within a time range of 200 years. Floods like this have occurred even more frequently than indicated by the 200 years' predictions and referring to climate changes, we may prepare for even more frequent events like this.



-  Potential risk of landslide
-  Trigger area - snow avalanche
-  Outlet area - snow avalanche

Figure 25b: Caution zones for landslide and snow avalanches. Scale 1:15 000.

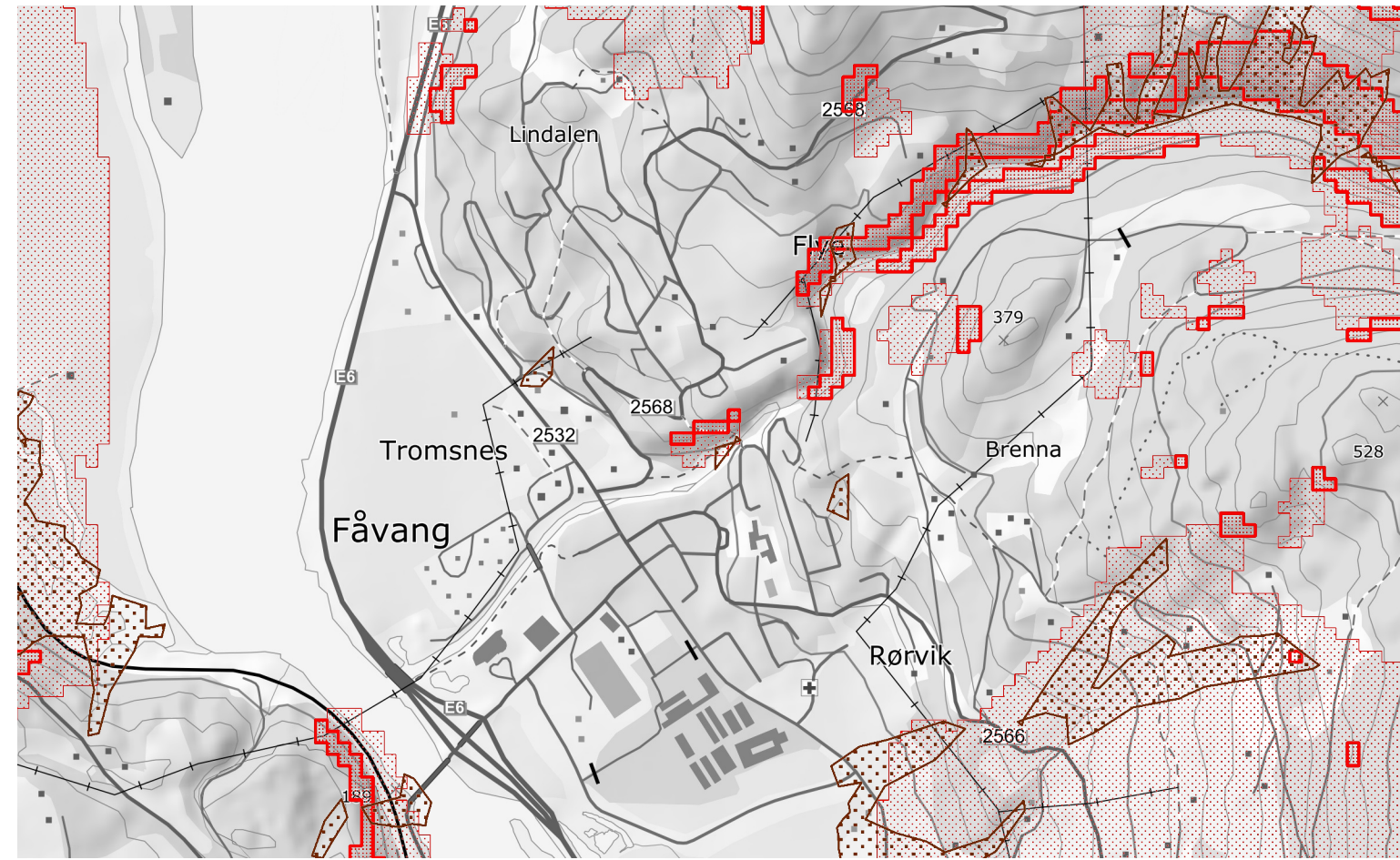

Figure 25c: 200-year flooding scenario. Scale 1:15 000.

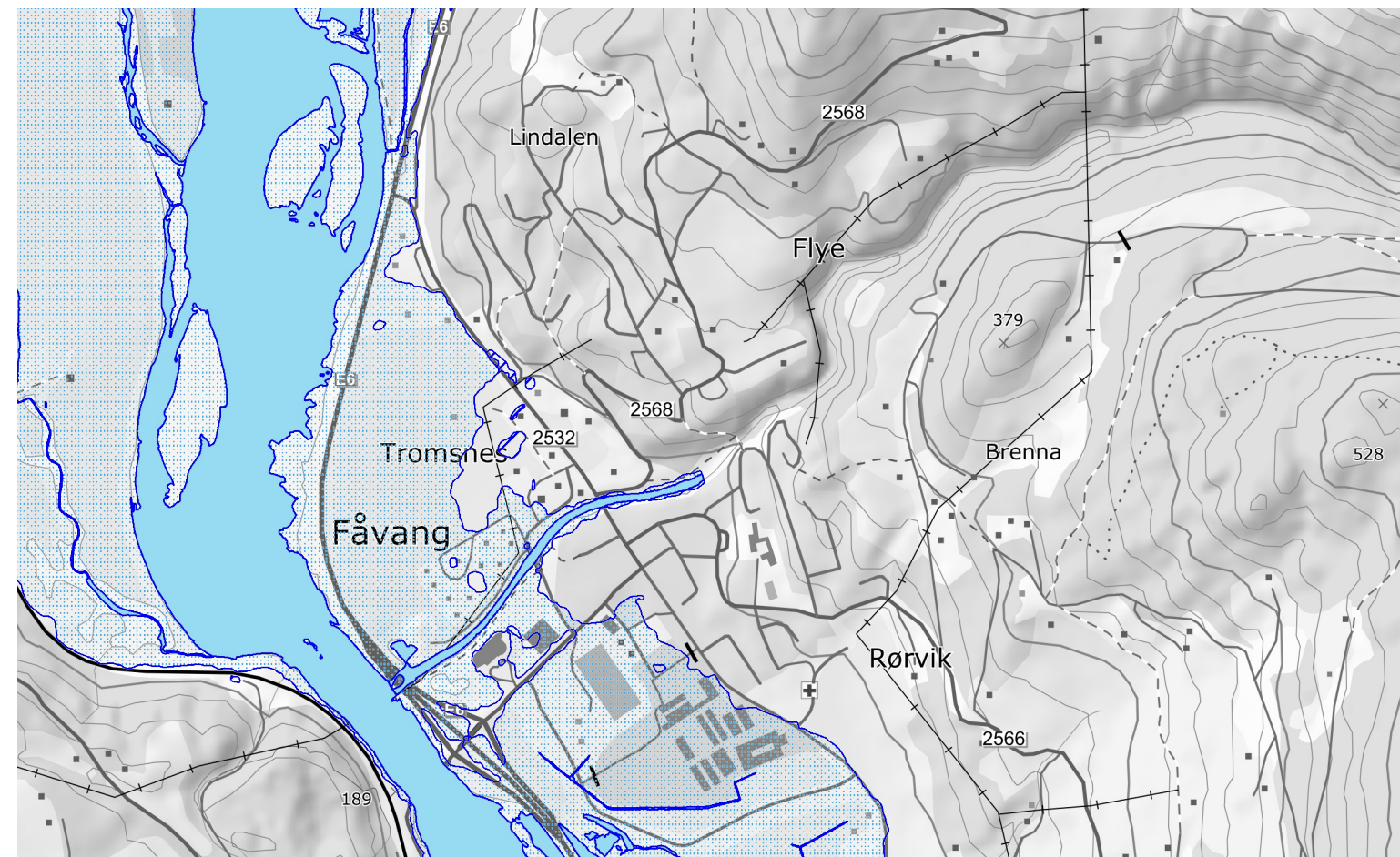

Figure 25a: One of the later floods in Fåvang. The year is not mentioned. View from the southeast (Photo: Veskje, K.).



# Regulation



Figure 26a: Regulation plan Tromsnesskogen (Image source: Ringebu municipality, 2014).



The 200-year flood zone of River Lågen and Tromsa is shown in both regulation maps as red diagonal lines. There are several buildings within this zone today. The map of Tromsnesskogen shows an area assigned for holiday cabins within the flood zone. In the southern parts of the map of Fåvang sør, significant land areas are allocated for business, industry, and parking within the flood zones. Referring to the map, at the south part of the river Tromsa starting at the outlet and stretching up to the second bridge, the river may be used for "extraction of raw material," as seen in the Fåvang sør map. This extraction involves removing excessive sediments transported in the river that has settled nearby the E6 bridge during flood events (NVE, 2013).

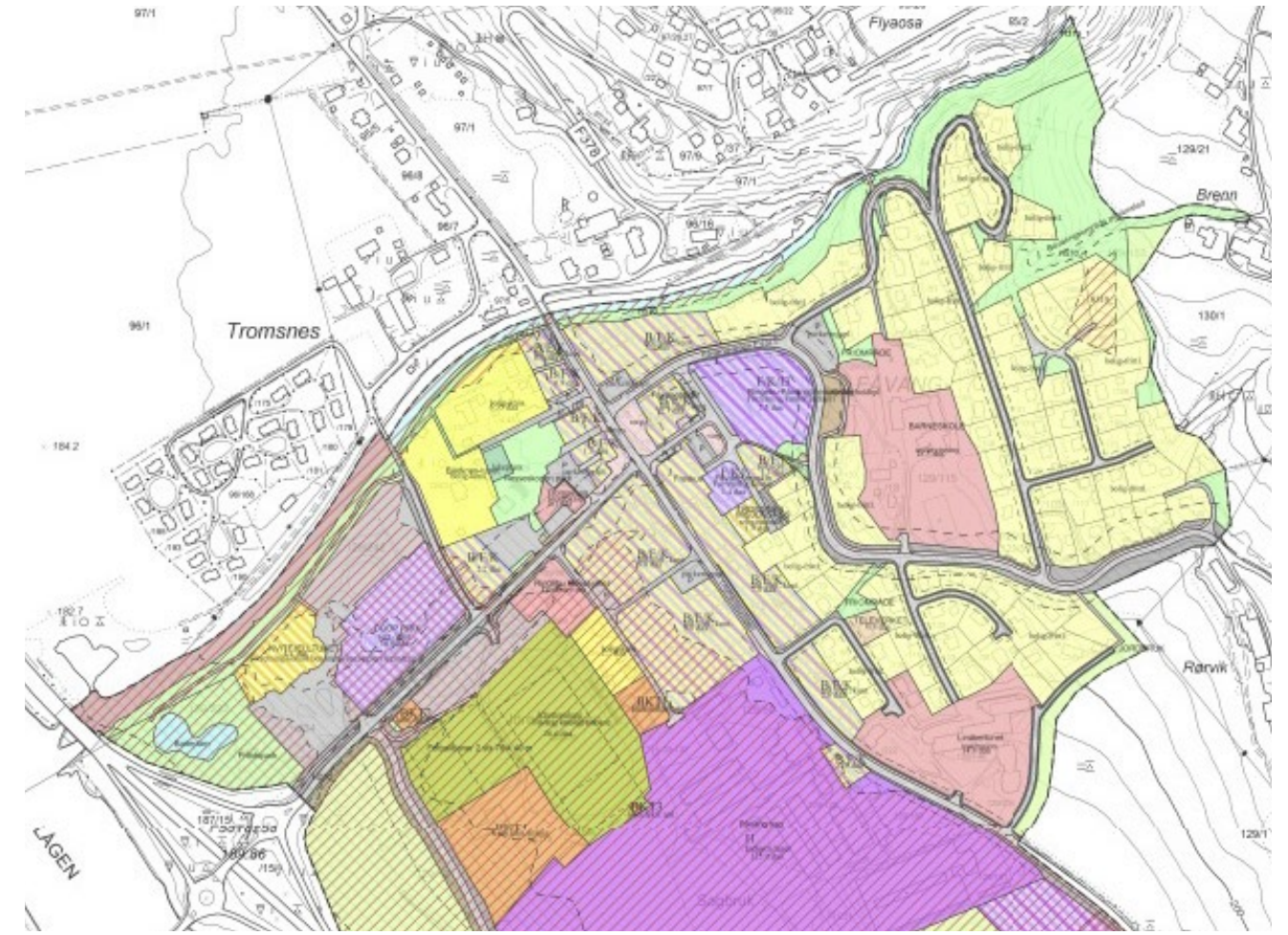
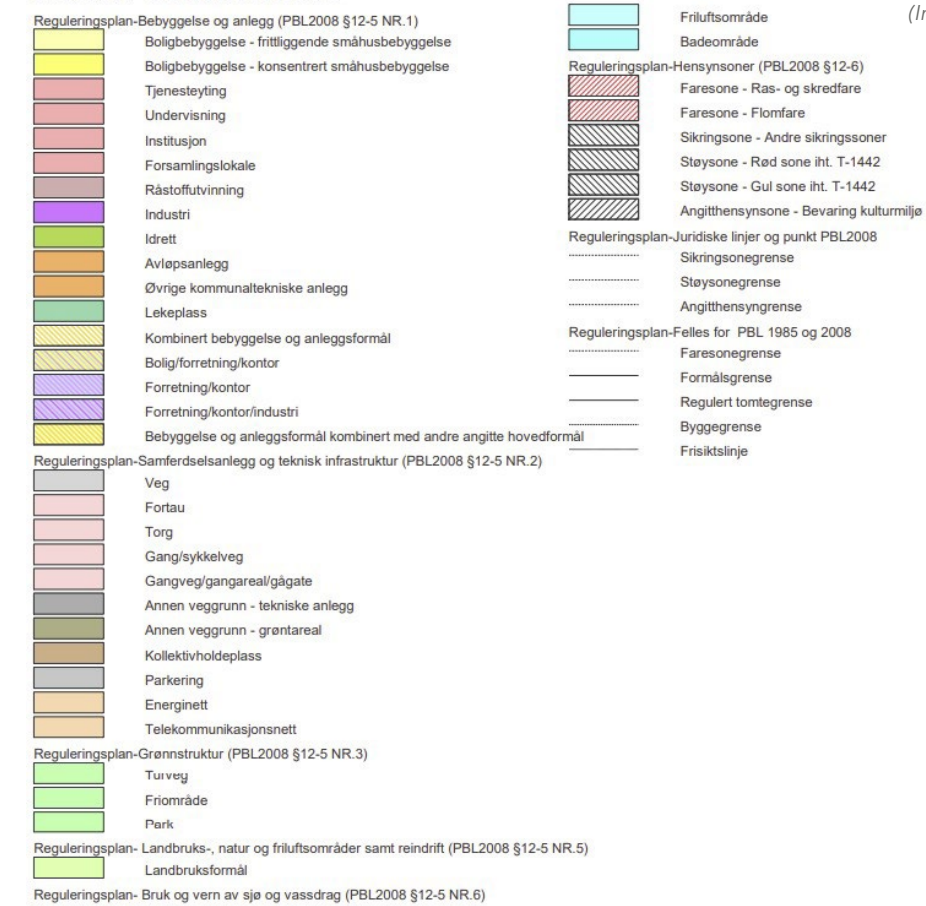

Figure 26b: Regulation plan Fåvang (Image source: Ringebu municipality, 2014).





## Let us get to know the place



Figure 27a: Cows of Fåvang (Photo: Fjeldberg, I. 2022).



Figure 27b: Ysterikroa with the high pipe (Photo: Fjeldberg, I. 2022).

Fåvang village is centered around the southern area of the river and the river outlet of Tromsa, with the city center on the south side of the river. The village has a calm atmosphere, as the site is rural, and the streets are quiet. Cars are driving through now and then, and a couple of people are walking along the streets. During the visits, most pedestrians seem to be walking toward the river Tromsa or the local cafeteria Ysterikroa. This building was used to produce dairy products such as cheese and butter and has been a meeting place for people in the town for several decades (Nordrum, 1995). You will find a few other commercial buildings in

the village center, but most have been transformed into offices or residential over the years. Agricultural landscapes surround the village outside of the built areas. Agriculture here consists mainly of crops, sheep, cattle, and forestry. Fåvang Sag covers most of the area south of the village center, almost out to Lågen. As Fåvang is located in a valley, hills covered with agricultural fields and forest, and mountains surround the village. Walking around the town, you can see the Kvitfjell mountain resort in the northeast from a close distance. When looking straight west, you will observe Myhre grustak, a local quarry.

Figure 27c: Town center of Fåvang (Photo: Fjeldberg, I. 2022).







Figure 28a: The landscape at a site a few kilometers up the valley in Fåvang (Photo: Fjeldberg, I. 2022).



Figure 28c: Huset Granmo- restored house from the 1800s that until recently served as accommodation for travelers (Photo: Fjeldberg, I. 2022).



Figure 28b: Pedestrian track from The high bridge to the pilgrimage rest stop (Photo: Fjeldberg, I. 2022).



Figure 28d: View of Tromsa river towards Lågen from the bridge at Tromsnesvegen (Photo: Fjeldberg, I. 2022).





Figure 29a: View from the High Bridge down to Tromsa, and the quarry on the other side of Lågen (Photo: Fjeldberg, I. 2022).



Figure 29b: Resting stop for pilgrimages (Photo: Fjeldberg, I. 2022).



Figure 29c: Resting stop (Photo: Fjeldberg, I. 2022).



## 4.2 Analyzing the landscape through its layers

The landscape around the Tromsa river and its outlet to the Lågen river is influenced mainly by agriculture, industry, and infrastructure. There is vegetation following the river sides, but the built areas shape the borders.

### Infrastructure

- Roads
- Europe road 6
- Railway

### Green areas

- Pinetrees dominating
- Deciduous vegetation
- Open grasslands

### Land use

- Agriculture
- Quarry
- Private housing
- Rental cabbins
- industry/ comercial

### Terrain and hydrology

- Lågen
- Tromsa
- ▼ Dam



Figure 30: (Diagram: Fjeldberg, I. 2022).



# History



Figure 31a: "Fåvang" (photo: Widerøe AS, 1952. Borrowed from Ringebu Historielagistorielag).

The river Tromsa has been playing an important role in the history of the village and is been described like this by one of the locals: "Det var vatnet som ga næring til den vesle spira som gjorde at tettsteillet voks fram her ved Tromsa i det førre århundreåret. Elva var livsnerven" (Nordrum, 1995). Direct translation: The water nurtured the tiny sprout that created the village by Tromsa in the previous century. The river was the life nerve. Den høye bro – translated to The high bridge, is a pedestrian bridge crossing Tromsa located where the

dam for hydropower production used to be. The high bridge has been mentioned in tales dated as far back as 1040 by the Famous story writer Peter Cristen Asbjørnsen. And a battle on the bridge between the Duke Skule and pilgrimages has been mentioned. Since then, the bridge has been upgraded several times, and today the pilgrimage route to Trondheim goes through the village of Fåvang and by this bridge. Moreover, this bridge is where the first road, "Den gamle tjødvegen" in Fåvang, was built (Hovdhaugen, 1976).



Figure 31b: A sketch of the High bridge at Tromsa, by Joach Frich from the 1840s. P. Chr Asbjørnsen described the experience of traveling over the bridge as something terrifying, with the fear of falling into the deep, dark hole that was the river Tromsa (Image source: Bygda vår, 1976, p.51)



After the first settlers came to Fåvang and the little village developed, the river was essential for daily life. Water mills were built in the 1800s, where the energy of the water ran the mills to grind grain. One of the known mills was Kvernstugua, which was placed close to the village center by the Øvre Tromsnes farm. At the farm Nedre Tromsnes, the water was used to process animal skins and fur at Garveriet. Across the river, the old sawmill Nessesaga was located, where the water was used to run the saw. The river's energy was also used for timber floating, but after the timber broke down the Bridge at the mill in 1921, this activity stopped (Hovdhaugen, 1976).

In 1916 the dam in Tromsa was built underneath the high bridge. This dam consisted of a concrete wall about 7 meters high. One year after the construction, a dynamo was installed to produce energy. Water pipes were stretched from the dam to the site near Kvennstua in the first years of the energy production. In 1936 the water pipes were extended to cross the river at Kvennstugua and over to Tromsa mølle og elkrafteverk, where the energy outtake was relocated. The energy production ended in the 1960s, and until January 2022, when the dam was partly removed, the dam's functions were mainly linked to recreational use.

## Driving forces

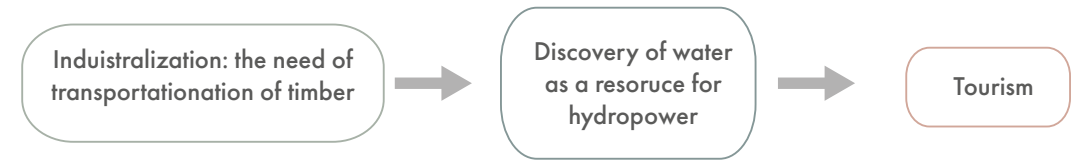
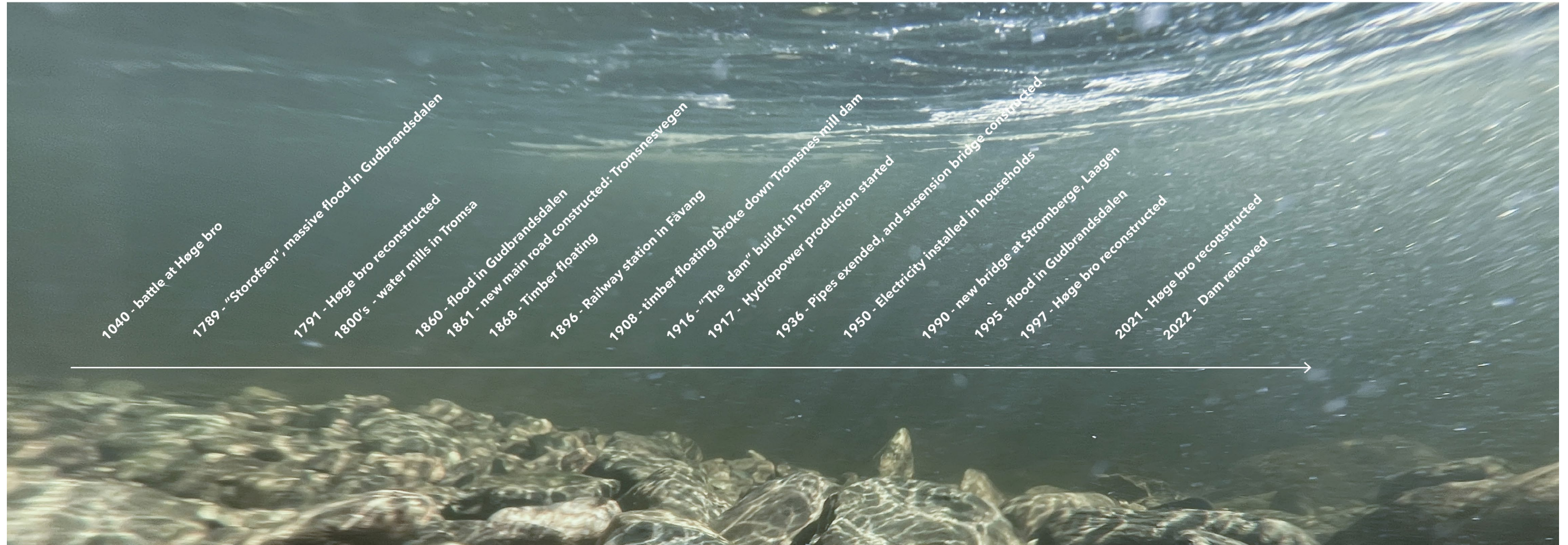

Figure 32: Events of importance for Tromsa river (Diagram: Fjeldberg, I. 2022).





# Important buildings and locations in the Tromsa area



Figure 33b: Route to the Ice church (map: Fjeldberg, I. 2022).





# Tromsa through time



Figure 34a: (Image source: Kart.Finn).

-  lost agriculture
-  Highway barrier
-  Industry and retail development
-  lost delta and wetland
-  Housing development



Figure 34b. Development in land use (Diagram: Fjeldberg, I. 2022).



Figure 34c. Areal photo from 2021 (Image source: Kart.Finn).



## Remaining wetland area

As mentioned in the section on wetland and river deltas (p. 26), it is a global trend that river deltas are changed and developed for socio-economic reasons and due to urban development, industrial development, agricultural intensification, and climate change impacts (Kuenzer & Renaud, 2012). The river delta in Fåvang is no exception. As shown in figure 34b, there has been a clear development in land use expansion since 1947. This time was the oldest description available of the area, but one may imagine by the patterns in the maps that the delta at the outlet of river Tromsa had more space further back in time as well.

In the reviews of remaining nature types in the Fåvang area, one of the biologists has commented that there have been great land areas consisting of flooded meadows and swamps south of the Tromsa river outlet, going back in time. And that the remaining wetland vegetation is only a small piece of what used to be (Miljødirektoratet, 2012b).

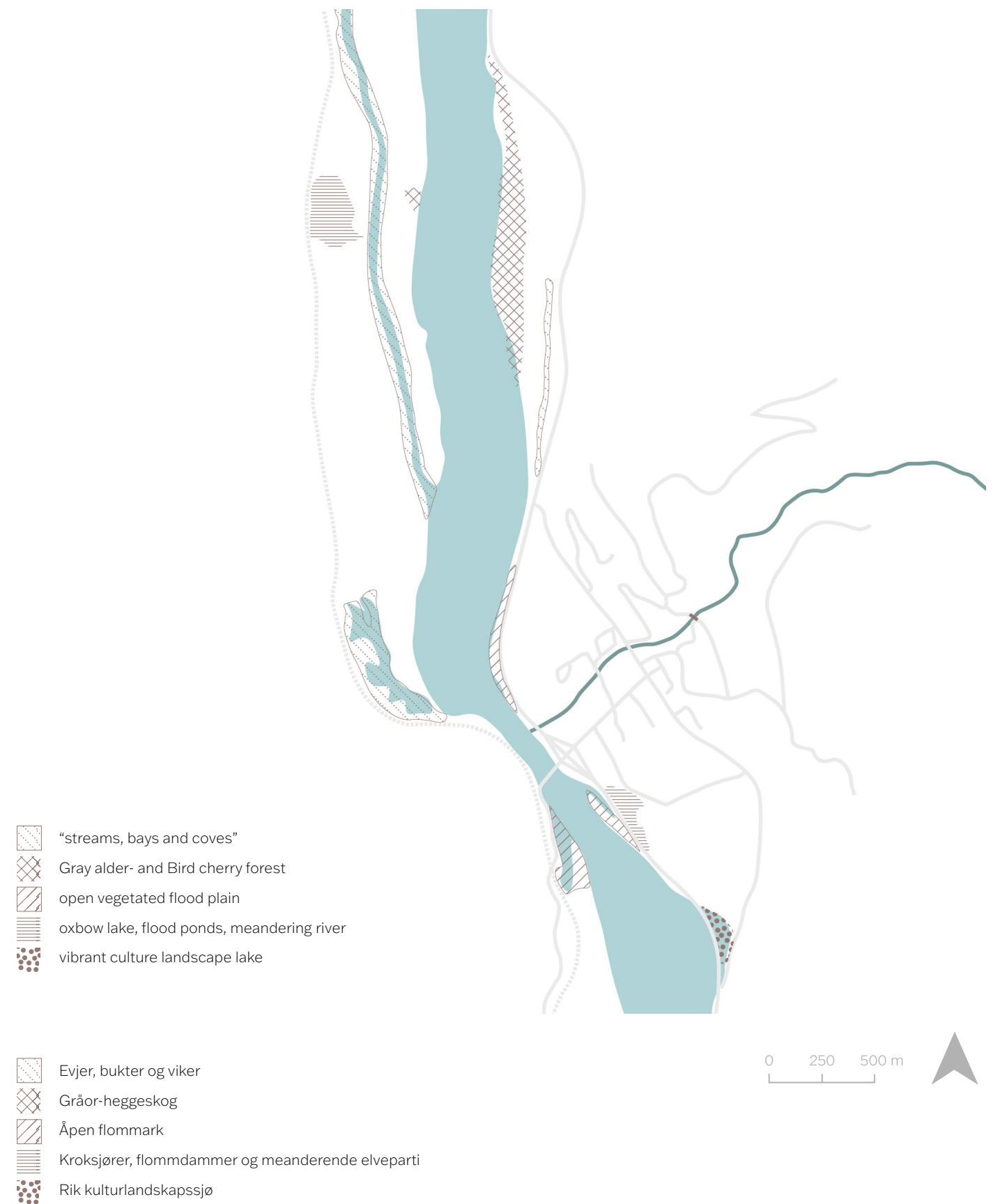

Figure 35: Remaining wetland areas (Map: Fjeldberg, I. 2022).

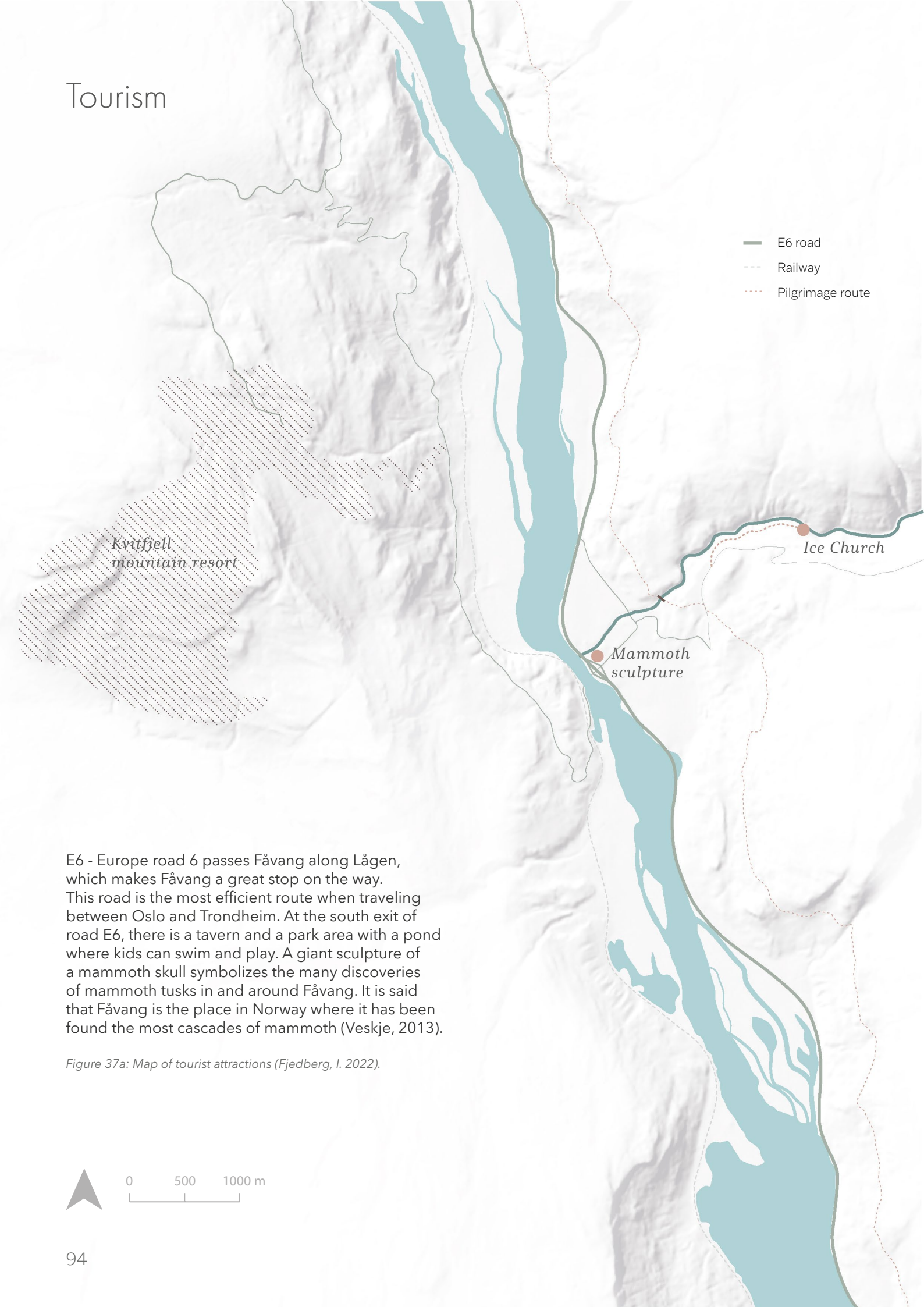



Figure 36: Photo from 1952 complemented with annotations of the border between agriculture and wetland at that time are marked in blue, and the Highway E6 that exists today in pink colour. (Original photo without annotations: Widerøe, 1952. borrowed from Ringebu Historielagistorielag).



# Tourism



E6 - Europe road 6 passes Fåvang along Lågen, which makes Fåvang a great stop on the way. This road is the most efficient route when traveling between Oslo and Trondheim. At the south exit of road E6, there is a tavern and a park area with a pond where kids can swim and play. A giant sculpture of a mammoth skull symbolizes the many discoveries of mammoth tusks in and around Fåvang. It is said that Fåvang is the place in Norway where it has been found the most cascades of mammoth (Veskje, 2013).

Figure 37a: Map of tourist attractions (Fjedberg, I. 2022).



Figure 37b: Markings of the pilgrimage route (Photo: Fjedberg, I. 2022).

The short distance to the Kvitfjell mountain resort may bring additional tourists. And in the wintertime, Fåvang provides its attraction, the Ice church, which has become a popular destination for people from around eastern Norway during the pandemic. The Ice church has been a local attraction since people first settled in Fåvang, and a local recreation group created a trail with informational posters, a fence, and boardwalks at exposed parts of the track. Sadly this trail has not been maintained for several years and would benefit from an update.

River Tromsa is a popular spot for Sports fishing; together with Lågen, Fåvang may be a hotspot for leisure fishing. The pilgrimage route Gudbrandsdalsleden goes through Fåvang, and The trail crosses Tromsa at the High bridge. Gudbrandsdalsleden stretches from Oslo to Tromdheim (Pilgrimsleden, no date)





Figure 38a: Parts of the trail that lead to the Ice church (Photo: Fjeldberg, I. 2022).



Figure 38b:  
Inside of the  
Icechurch (Photo:  
Lie, H. 1902.).



Figure 38c:  
The Ice church,  
(Lie, H. 1928,  
borrowed  
from Ringebru  
Historielag).



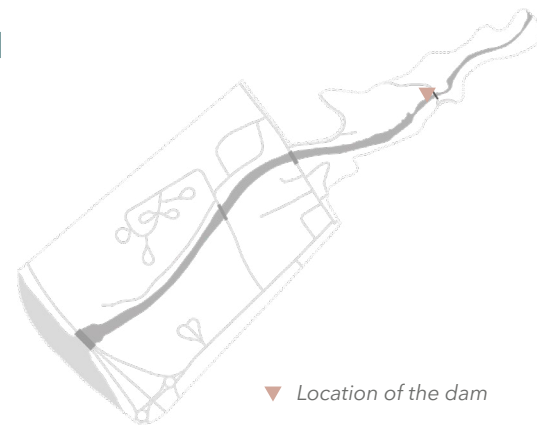

Figure 39: Tromsa dam in 1917 (Photo: 1917, borrowed from Ringebu Historielag).



# The dam and removal in river Tromsa

The dam in the Tromsa river was initially constructed to power a mill in 1916 but was later used to produce hydropower. Energy production was in operation from 1917 until the 1960s, until its removal in 2022. As of early fall 2022, approximately 2 meters (vertically) of the dam construction is still left and is planned to be removed soon. The illustrations below show how the dam was before removal.



The inside of the dam had a hatch at the bottom right (seen from the inside) corner to regulate water masses. This hatch had been filled with sediment masses and had become unable to open after years of sediment transportation. After demolishing the wall, these sediment masses were divided down the riverbed—parts downstream and the rest upstream from where the dam was removed. Bigger stones from the local quarry were brought to the site and placed carefully to shape pools for the fish to recreate a preferred environment and habitat (Sørås et al., 2018).

Figure 40c: A length section of the dam included digging slopes (Image source: Multiconsult, 2018).

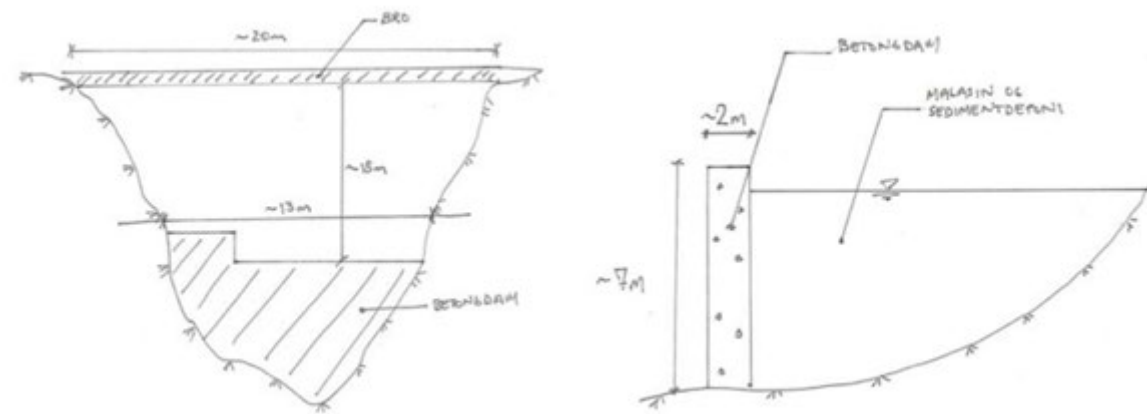

Figure 40a: Descriptive illustrations of the dam, not in scale. The first sketch is downstream, and the second is a length section (Image source: Multiconsult, 2018).

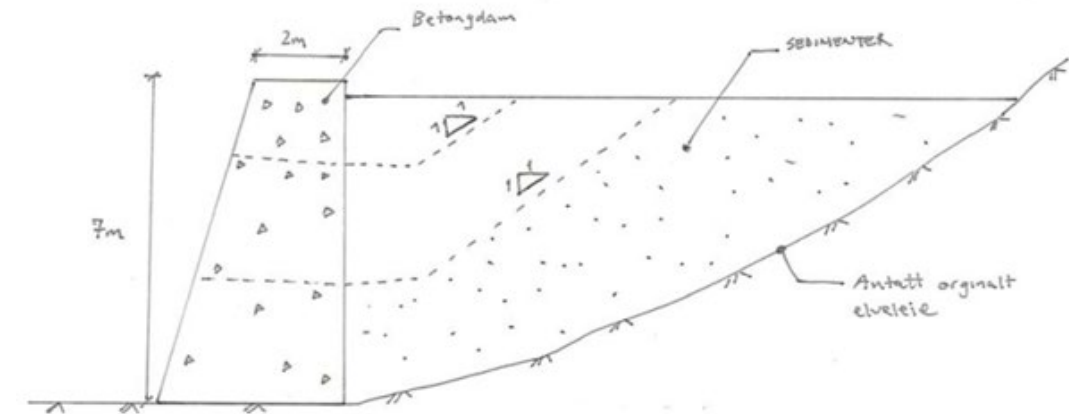

Figure 40b: The inside of the dam after construction (Photo borrowed from Ringebu Historielag).

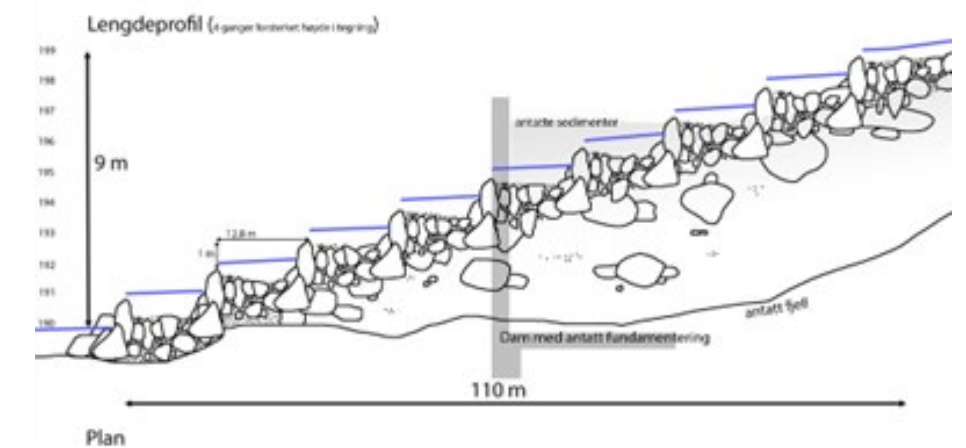

Figure 40d: The profile shows the planned division of the sediments and the construction of fish pools after removing the dam wall (Image source: Multiconsult, 2018).

The dam construction was demolished using explosives and then removed by an excavator in January 2022, when the water and temperatures were low. A temporary road was constructed to reach the dam with the big machine for removal (Dam Removal Europe, 2022b). In order to build the road, trees and vegetation were removed, and soil was transported and added to the site. During the spring flood, parts of this road got flushed away.





Figure 41a: Photo of a characteristic site in the Tromsa river (Photo: borrowed from Ringebu Historielag).

Imaginary situation before the construction of the dam

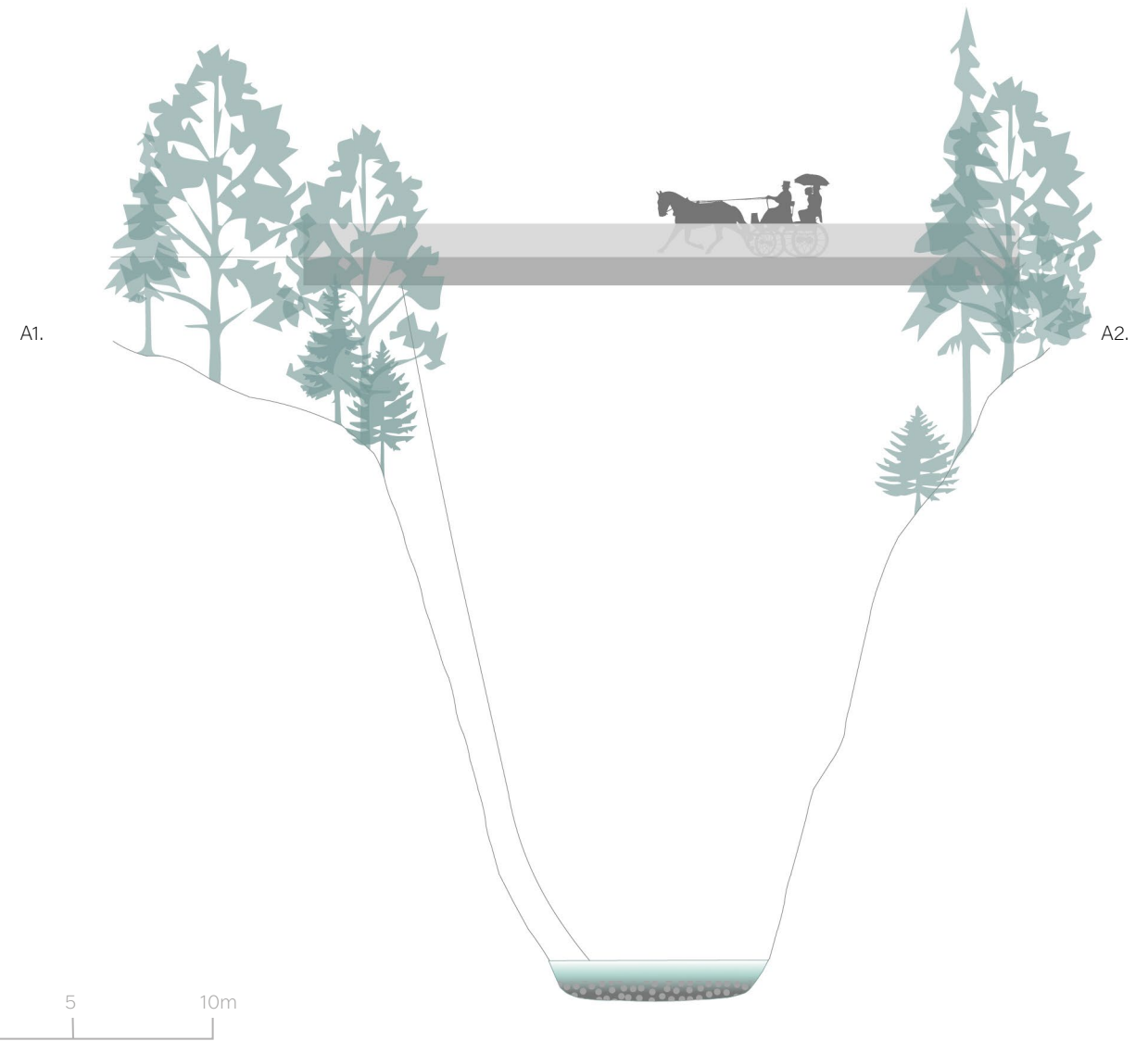
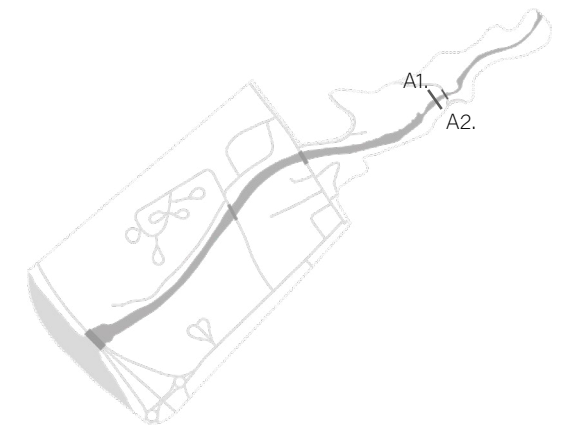
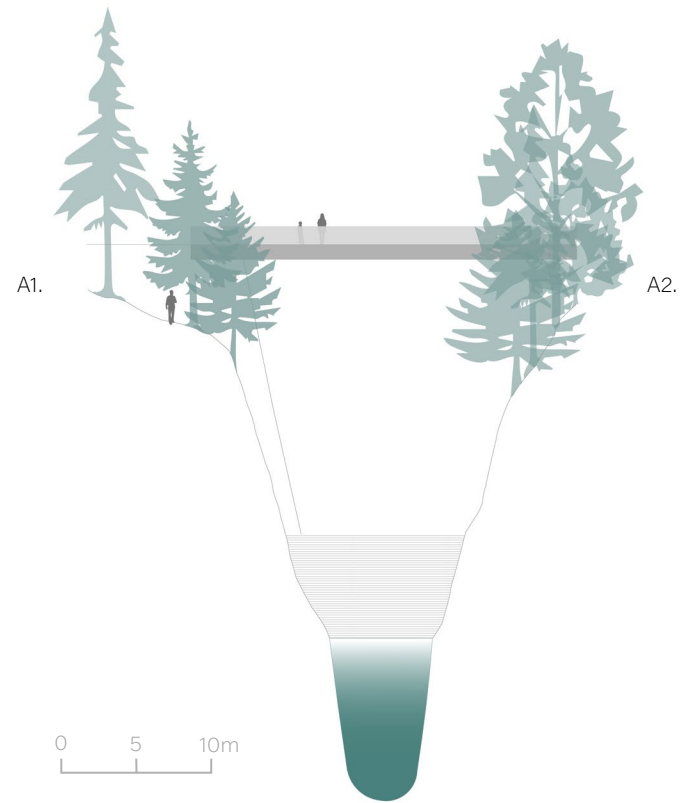

Figure 41b: Section A1-A2 - 1 (illustration: Fjeldberg, I. 2022).



### Imaginary situation with the dam present

Figure 42a: Section A1-2 - 2. The water masses had eroded a ditch approximately 11 meters deep during the time that the dam was present (illustration: Fjeldberg, I. 2022).



### Situation after partly removal of the dam

Figure 42b: Section A1-A2 -3. After the dam's removal, the deep ditch in the riverbed was filled with sediments that had been stored behind the dam's wall (illustration: Fjeldberg, I. 2022).

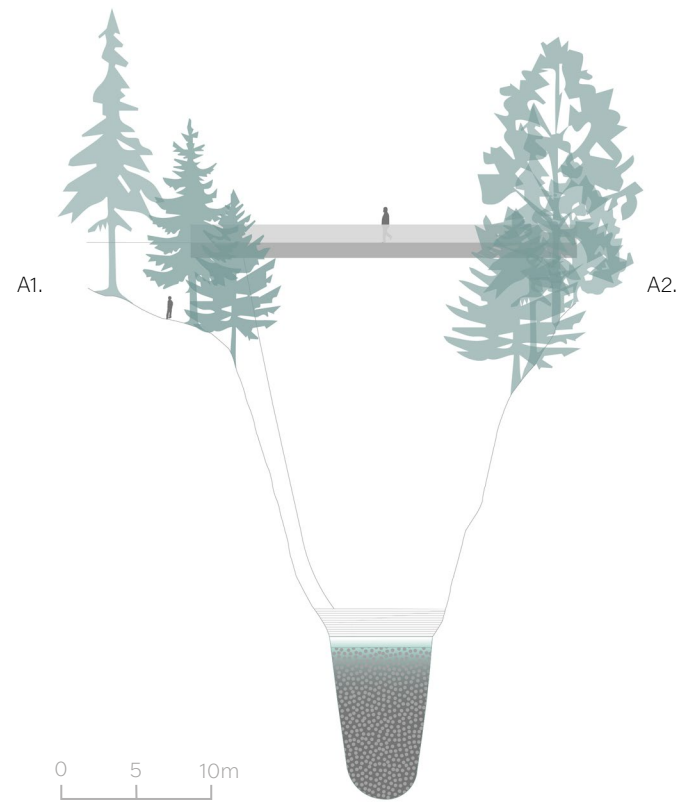

Figure 42c: "Dangerous passing over Tromsa at Trones" (Vigerudst, A. no date).





Unfortunately, due to strong currents in the river during the spring flood, the stones placed to create the habitat pools have been moved downstream. As a result, the constructed habitats are not in the preferred shape today.

After the main parts of the dam have been removed, it may have opened up an opportunity for the fish to migrate about 1 - 2 kilometers further up in Tromsa than they were able to before the dam removal project.

*Figure 43a: Situation after construction of habitat pools (Photo: Solbakken, T. 2022).*



*Figure 43b: Situation in August 2022, after the spring flood had moved the rocks (Photo: Fjeldberg, I. 2022).*



# Energy production

With the dam, it became possible to produce energy locally. The production happened in the basement of the building, which used to be a mill before the installation of a dynamo. Therefore the building is named Tromsø Mølle og Elverk. The building was also used as a general store. The production elements are still intact in the basement of Tromsø Mølle og Elverk. Pipes with water crossed the river upstream of the building and led it through the dynamo and installations inside the building before it was discharged back into the river. Hydropower production stopped in the 1960s when the hatch for the water pipes at the dam could not open anymore due to sediment accumulation.

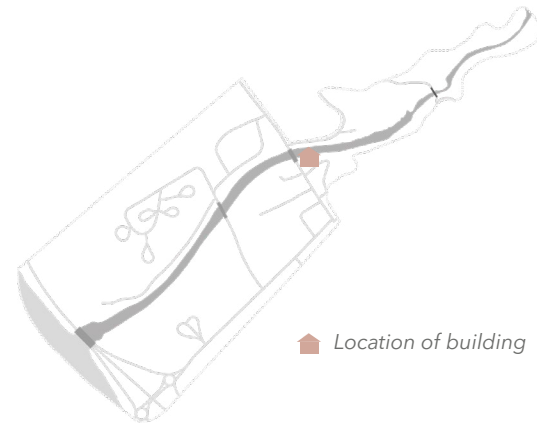

Figure 44a: Hydropower was produced in the basement of this building (Photo: Fjeldberg, I. 2022).



Figure 44b: Unit tag (Photo: Fjeldberg, I. 2022).

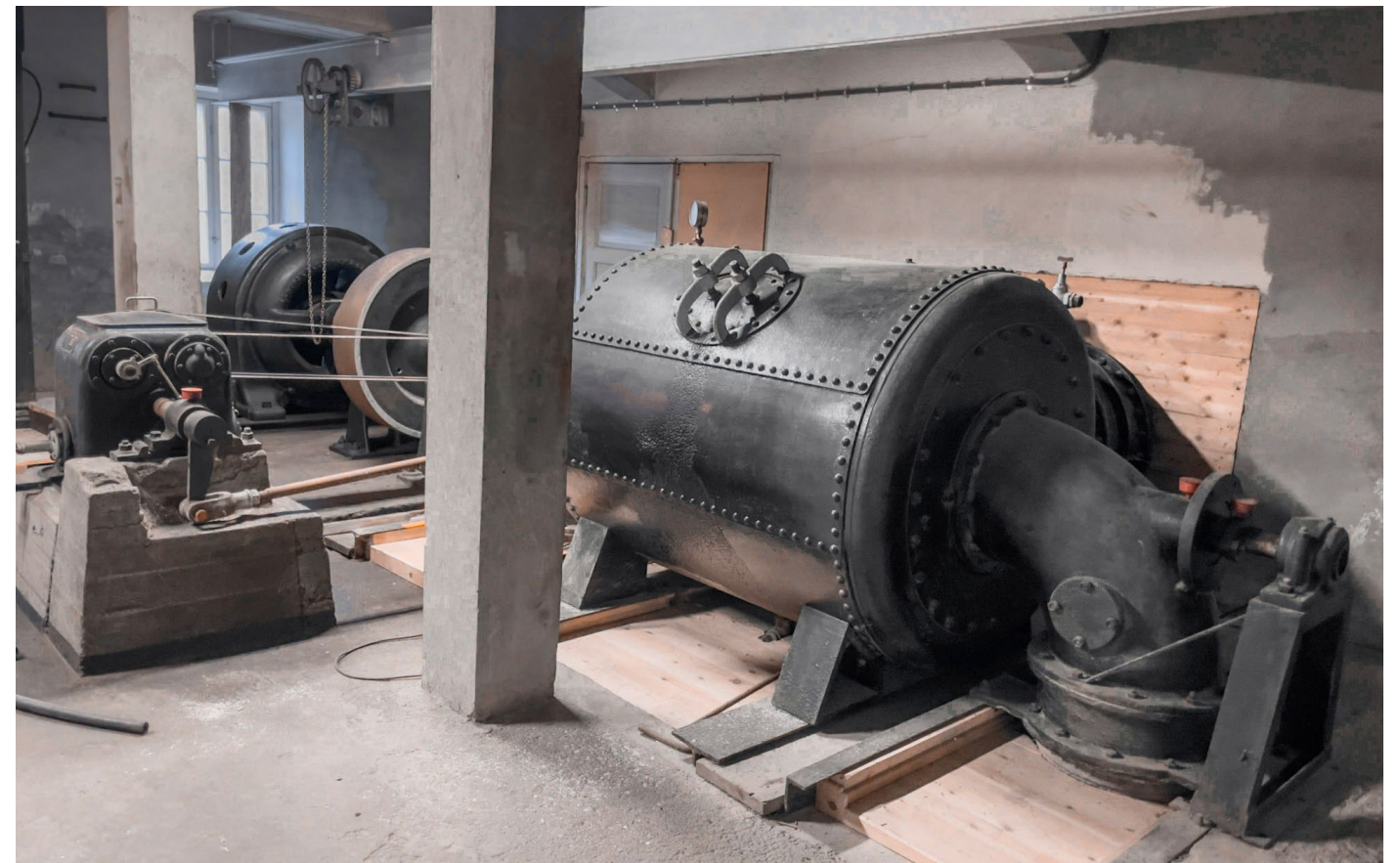

Figure 44c: Generator unit (Photo: Fjeldberg, I. 2022).



Figure 44d: Monitors (Photo: Fjeldberg, I. 2022).

Figure 44e: The hydropower station (Photo: Fjeldberg, I. 2022).





# Stakeholders at Tromsa

## Local community

The community in Fåvang used the site for recreational purposes before the dam was removed. For about 100 years, the dam had been in the river and created this constructed waterfall underneath the High bridge. This was now the way most of the locals knew this site at Tromsa. Locals have described that people swam in the river downstream of the dam in the summertime. Some dareful people even jumped from the cliffs on the sides. The riverside has been used for campfires, and there has been a concert in the wintertime. The landscape is still primarily intact around the river, except for the erosion and damage by the constructed road for the big machines. And parts of the trail up to the High bridge have also eroded. In the river itself, the rocks placed in the spring have been moved by the water. And a couple of wires that were used to fasten the stones are now visible after the rearrangement. As a result, the ability to swim at the usual spot has been reduced, according to stakeholders.

## Anglers

Tromsa and Lågen were popular spots for anglers also when the dam was present.

## Flora and fauna

The animals, fish, plants, fungi, and microorganisms in the ecosystem surrounding the river Tromsa are all important stakeholders of the site. Their voices are not so easily heard, and they must not be forgotten in the process of interference in their home.

## Pilgrimages

Occasionally pilgrimages cross the river on the route. A trail that runs along the river between the High Bridge towards the town center is marked with pilgrimage signs, allowing the option to walk along the river down to the town center. The route is marked in the following map, as well as in figure 33a (p.86) and figure (37a, p. 94).

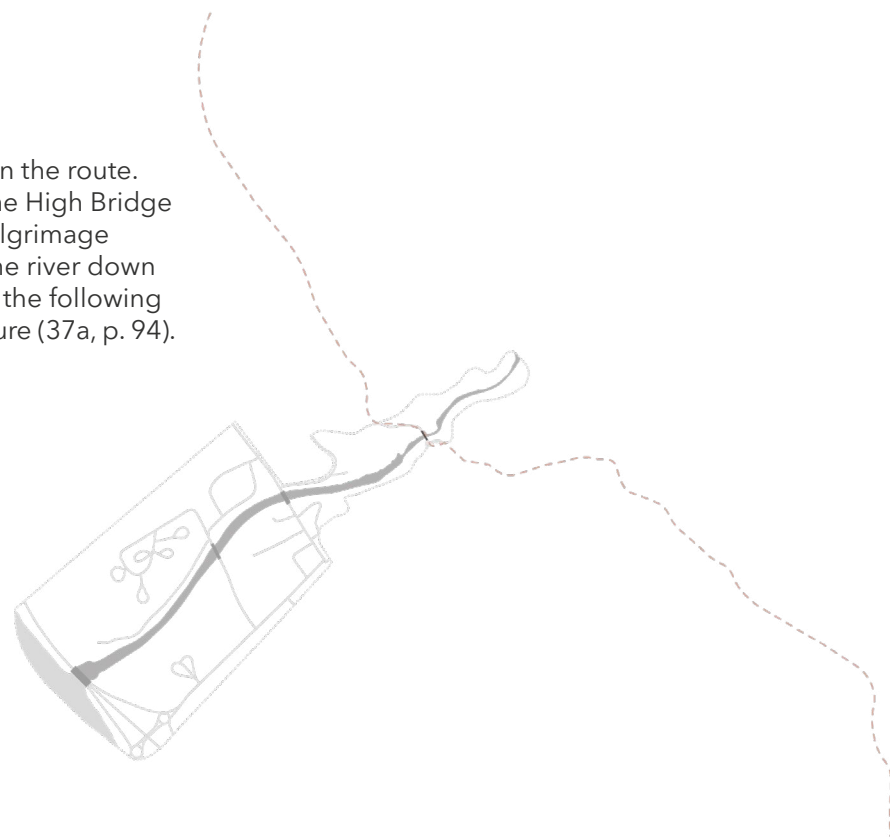

Figure 45a: Map indicating pilgrimage route (map: Fjeldberg, I. 2022).



Figure 45b: The site at the dam before removal. The photo was taken before the latest replacement of the High bridge (Photo: Ringlund, O. 2020).

Figure 45c: Closer view of the dam before removal (Photo: Ringlund, O. 2020).





## Site visits

In my research, I have conducted several site visits and observational analyses. I have spent time at the dam site, moved around, and familiarized myself with the surroundings. Some discoveries in the field where at the site the dam was removed are shown on the map on pages 114-115.



Figure 46a: A trail leading beside the dam and to the pilgrimage route and the High bridge (Photo: Fjeldberg, I. 2022).



Figure 46b: View into the open meadow in Room 2, annotated in the map on page 114 (Photo: Fjeldberg, I. 2022).



Figure 46c: Pipes that used to transport the water from the dam over to Tromsa mølle og elverk (Photo: Fjeldberg, I. 2022).



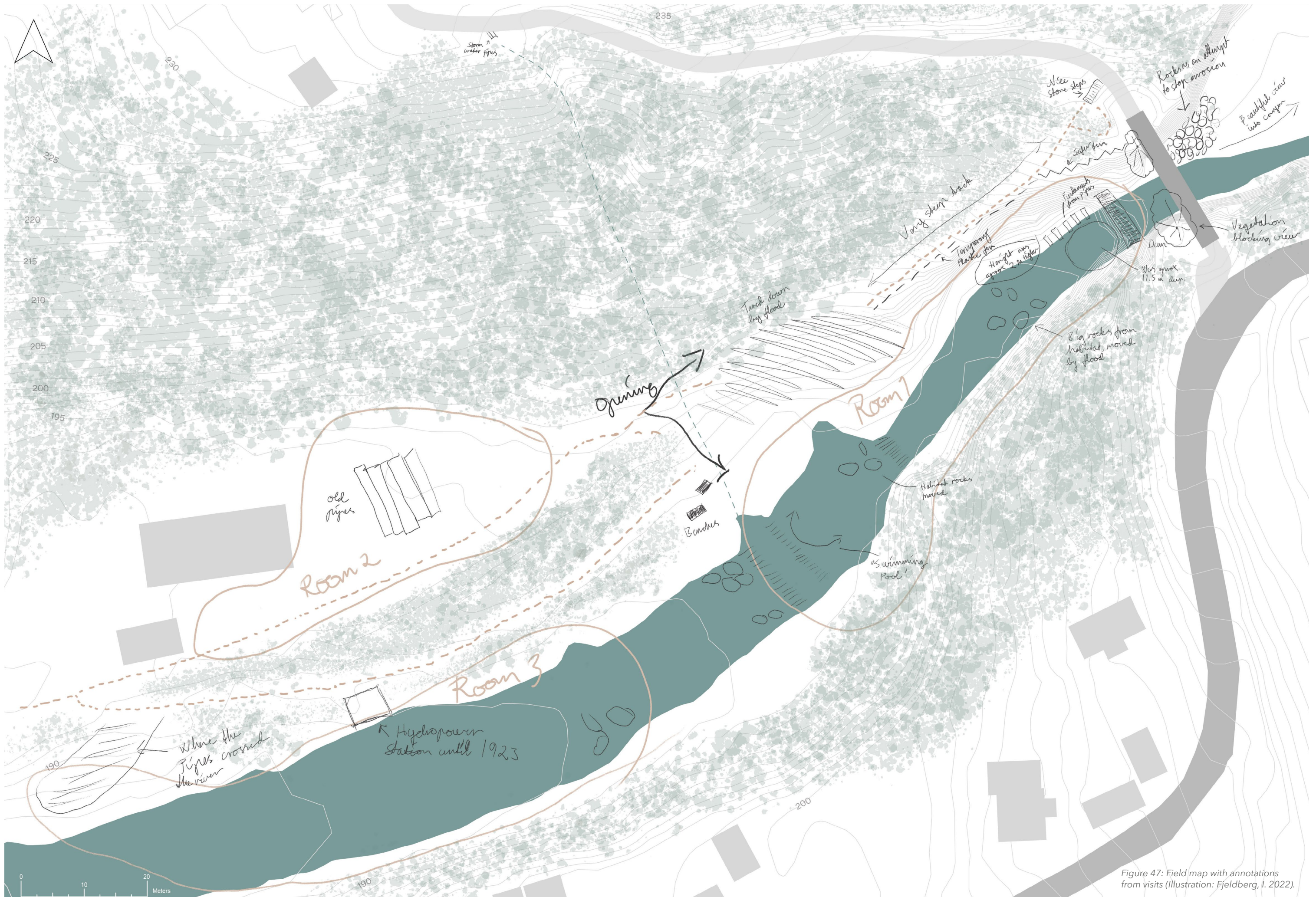

Figure 47: Field map with annotations from visits (Illustration: Fjeldberg, I. 2022).



## Noise barriers

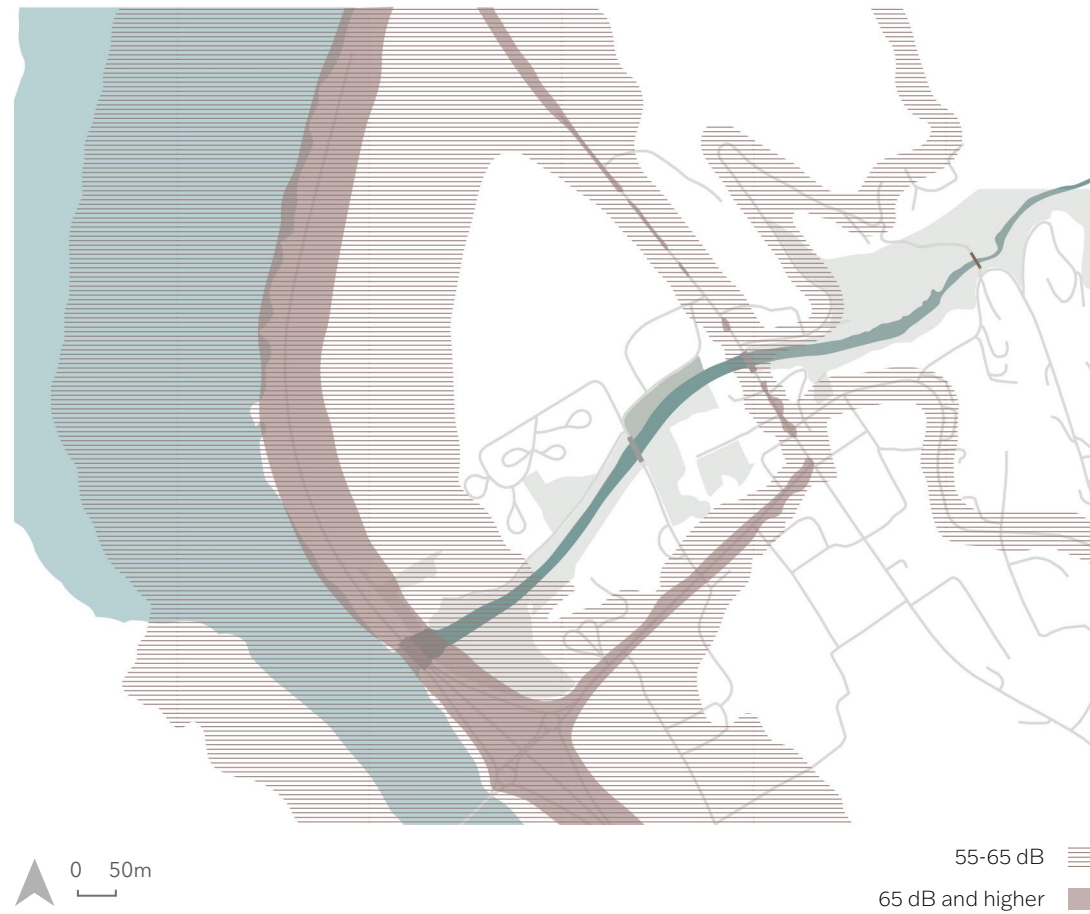

Figure 48a: Sound barriers from the infrastructure  
(Map: Fjeldberg, I. 2022).

With our modern infrastructure, there is also noise. The map gives an impression of the impact the sound from the most used roads are having on the environment. At the dam site, there is also sound from the water at the remaining level of the dam, which can be high in volume, even when the water level in the river is low. This is a different type of sound, and since it is related to nature, it does not have the same negative impact as noise from human infrastructure.



Figure 48b: *Campanula rotundifolia* at the riverside (Photo: Fjeldberg, I. 2022).



## Geology at the site

At the dam site and further upstream, geology consists of slatestone from organic material at the steep canyons close to the water. While in the river, the rocks seem to mix with a large amount of more complex material consisting of more quartz. The round shapes of these rocks indicate they have been transported and shaped by the river for thousands of years. As a result of the nutrient-rich geology of the slatestone, containing iron and most lightly lime, vegetation is blooming, and trees are growing densely. Moving toward Lågen, the landscape is flat, and the soil consists of sediments from the river delta.



Figure 49a: Porous and nutrient-rich geology around the river allowing vegetation to settle on most surfaces (Photo: Fjeldberg, I. 2022).

Figure 49b: Variation in rock sizes in the river (Photo: Fjeldberg, I. 2022).

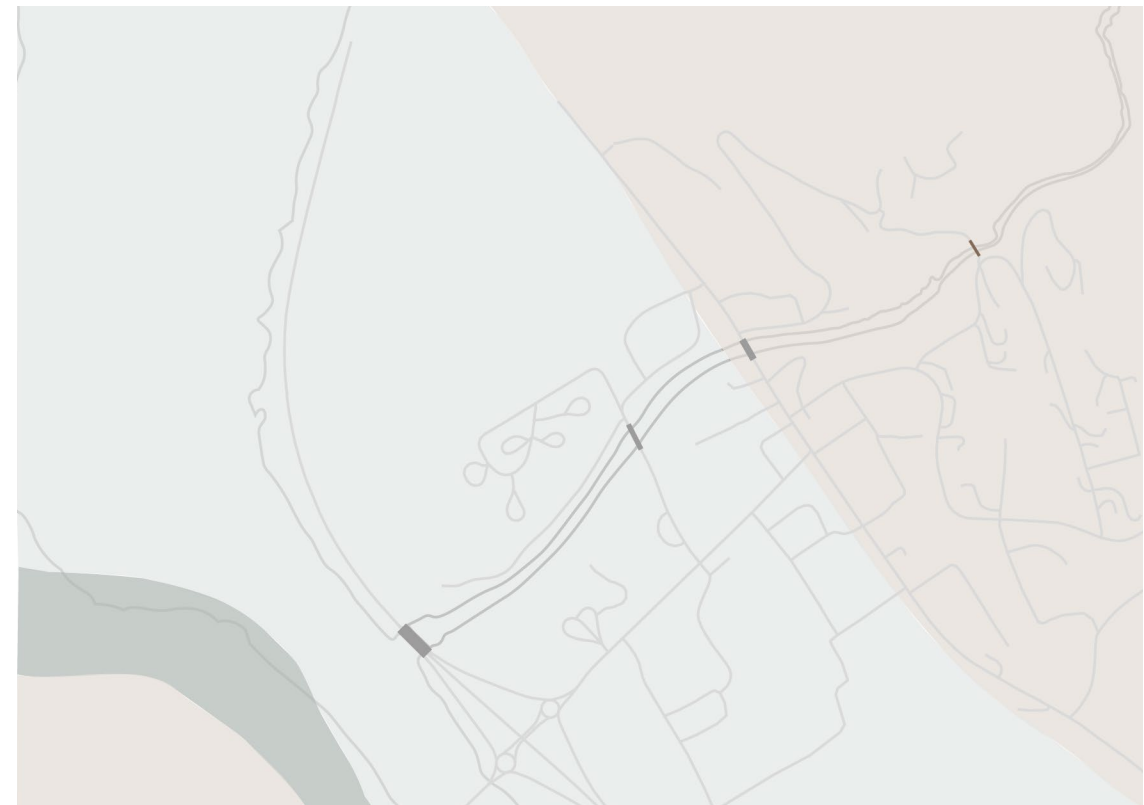

- Sandstone and slate (main rock: sandstone)
- Soil, loose material
- Biri slate and lime (main rock: slate)

0 50m

Figure 49c: Bedrock map showing Tromsa from Lågen and to the dam site (Map: Fjeldberg, I. 2022).

Figure 49d: View into the canyons from the High bridge (Photo: Fjeldberg, I. 2022).







Figure 50: The dam site seen in August (Photo: Fjeldberg, I. 2022).



# Ecology of the river

Tromsa river has vibrant flora and fauna. During site visits, I observed trout jumping in the river, White Dipper, and traces of beaver. According to Artsdatabanken, otters and several wetland birds live in the rivers. The plant community consists of water-tolerant tree species, grasses, herbs, and vascular plants that enjoy a humid climate. A selection of plants observed during site visits is listed in figure 52a (p. 126).



Figure 51a: *Phegopteris connectilis* (Photo: Fjeldberg, I. 2022).



Figure 51d: *Omphalodes verna* (Photo: Fjeldberg, I. 2022).



Figure 51e: *Alnus incana* (Photo: Fjeldberg, I. 2022).



Figure 51b: The first stage of succession after the excavator removed the dam (Photo: Fjeldberg, I. 2022).



Figure 51c: *Picea* (Photo: Fjeldberg, I. 2022).



Figure 51f: *Rubus idaeus* (Photo: Fjeldberg, I. 2022).



Figure 51g: *Vaccinium vitis-idaea* (Photo: Fjeldberg, I. 2022).



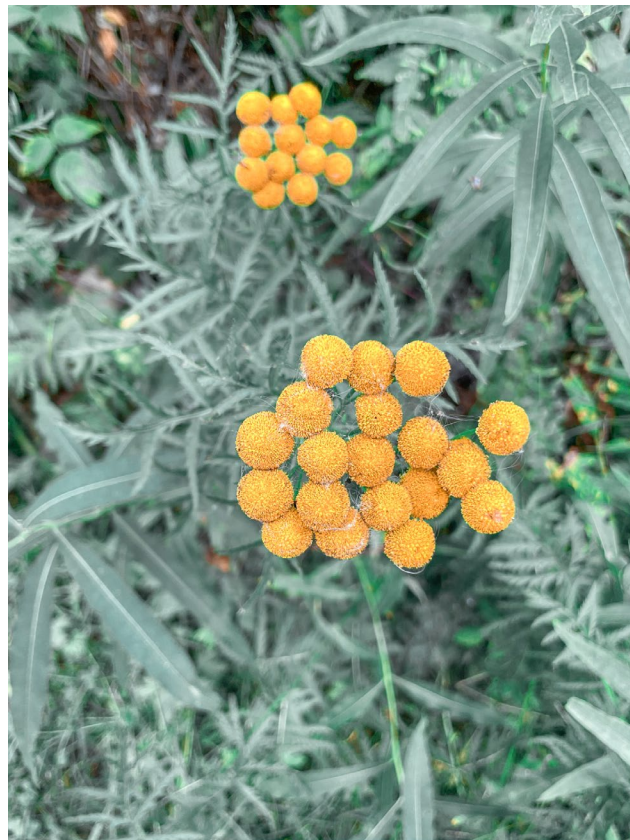

Figure 51h: *Tanacetum vulgare* (Photo: Fjeldberg, I. 2022).

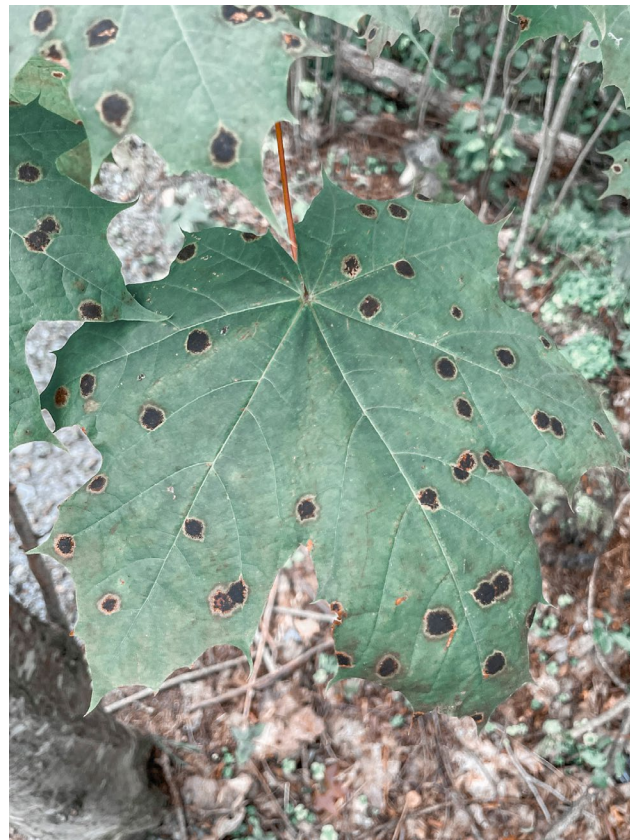

Figure 51i: *Acer platanoides* (Photo: Fjeldberg, I. 2022).



Figure 51j: *Athyrium filix-femina* (Photo: Fjeldberg, I. 2022).



Figure 51k: *Chamaenerion augustifolium* (Photo: Fjeldberg, I. 2022).

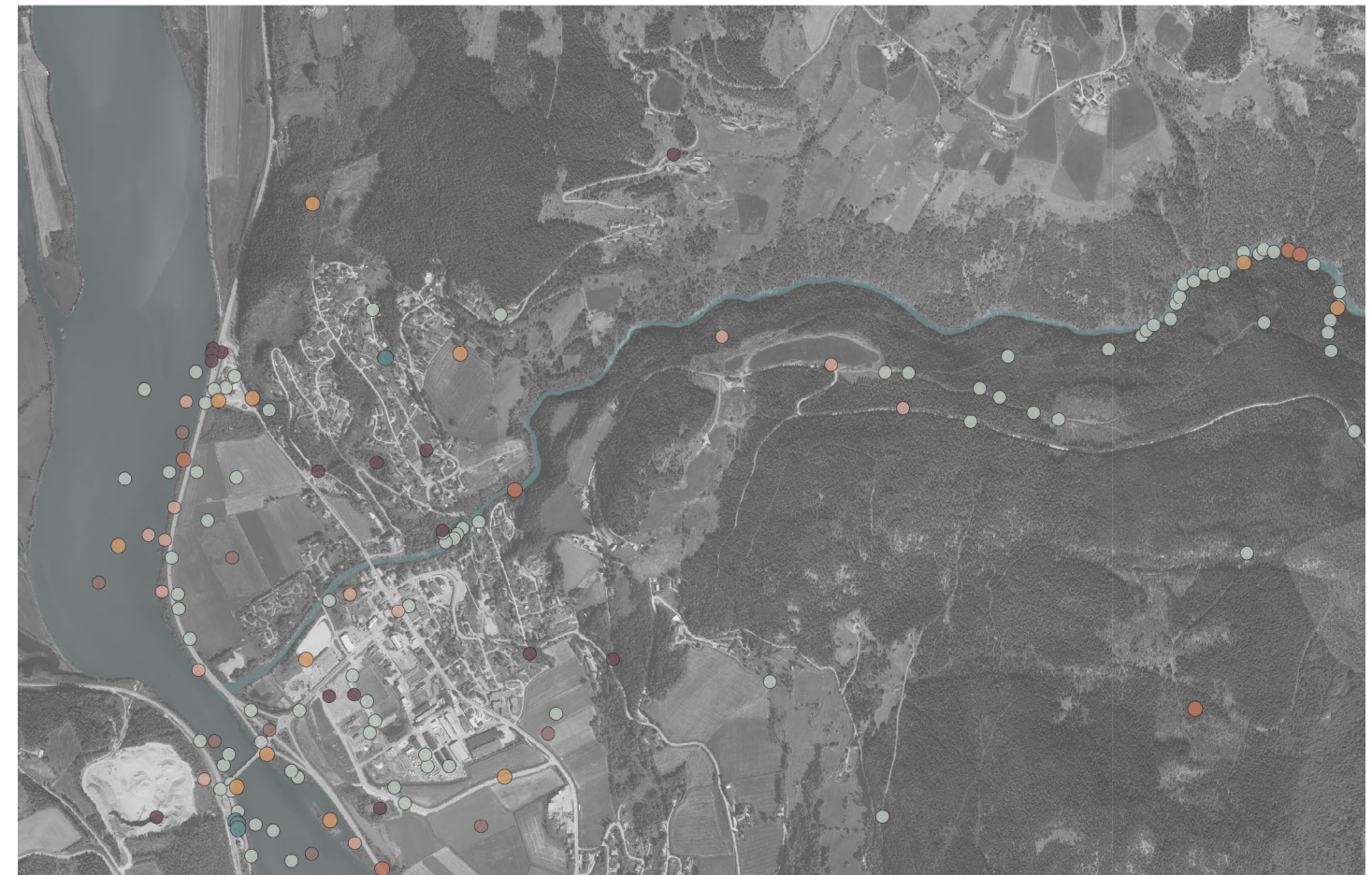

Figure 51l: Species registered between 2002 - 2022 at Artsdatabanken. The map is based on Artsdatabankens registrations of vulnerable, viable, and invasive species (Map: Fjeldberg, I. 2022).

- SE - Very high risk
- CR - Critically threatened
- PH - Potentially high risk
- LC - Viable
- EN - Highly threatened
- NT - Nearly threatened
- VU - Vulnerable

Both vulnerable and invasive species have been registered in areas surrounding Tromsø and its river outlet to Lågen. Among invasive species, the *Impatiens glandulifera* seems to be reported most frequently, while wetland birds make up most of the threatened and vulnerable species. The *Impatiens glandulifera* is also among the species I registered during my visits, as shown in the table below. In addition, a few wetland plants, such as the *Stellaria palustris* and *Salix triandra* L., categorized as vulnerable, are registered at the riverside of Lågen (Artsdatabanken, 2022).



## Observed plants and mushroom around Tromsa river

Name	Scientific name	Type of vegetation	Classification at Artsdatabanken
The grey alder	<i>Alnus incana</i>	tree	LC - Viable
Spruce	<i>Picea</i>	tree	
Norway maple	<i>Acer platanoides</i>	tree	LC - Viable
Scots pine	<i>Pinus sylvestris</i>	tree	LC - Viable
Birch	<i>Betula pubescens</i>	tree	LC - Viable
Goat willow	<i>Salix caprea</i>	tree	LC - Viable
Rowan	<i>Sorbus aucuparia</i>	tree	LC - Viable
Common hazel	<i>Corylus avellana</i>	shrub	LC - Viable
Red raspberry	<i>Rubus idaeus</i>	shrub	LC - Viable
Tansy	<i>Tanacetum vulgare</i>	herb	LC - Viable
Fireweed	<i>Chamaenerion augustifolium</i>	herb	LC - Viable
Great Stinging Nettle	<i>Urtica dioica</i>	nettle	LC - Viable
Wild strawberry	<i>Fragaria vesca</i> L.	fruit, rose family	LC - Viable
Northern lady fern	<i>Athyrium filix-femina</i>	fern	LC - Viable
Wood Avens	<i>Geum urbanum</i>	herb	LC - Viable
Lingonberry	<i>Vaccinium vitis-idaea</i>	small shrub	LC - Viable
Blueberry	<i>Vaccinium myrtillus</i>	small shrub	LC - Viable
Common polypody	<i>Polypodium vulgare</i>	fern	LC - Viable
Fly agaric	<i>Amanita muscaria</i>	mushroom	LC - Viable
Northern beech fern	<i>Phegopteris connectilis</i>	fern	LC - Viable
<b>Invasive / alien Species</b>			
Common lilac	<i>Syringa vulgaris</i>	tree	NR - not rated
Siberian Pea Tree	<i>Caragana arorescens</i>	tree	HI - high risk
Himalayan Balsam	<i>Impatiens glandulifera</i>	herb	SE - very high risk
Blue-eyed-mary	<i>Omphalodes verna</i>	herb	LO - low risk
Redcurrant	<i>Ribes rubrum</i>	berry shrub	NR - not rated

Figure 52a: List of observed plants and mushrooms at Tromsa (Table: Fjeldberg, I. 2022).

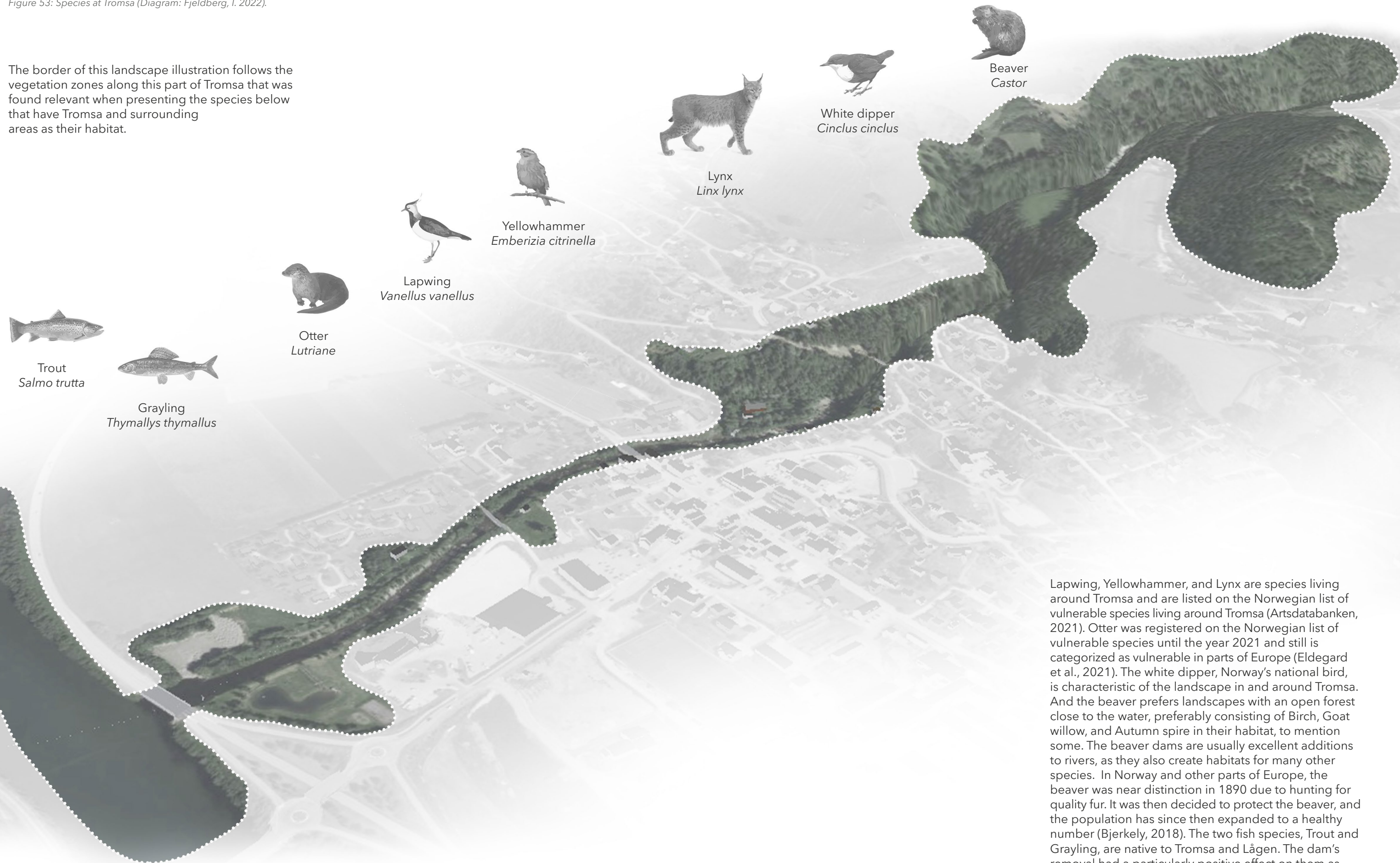

Figure 52b: Trail toward the dam site (Table: Fjeldberg, I. 2022).



Figure 53: Species at Tromsa (Diagram: Fjeldberg, I. 2022).

The border of this landscape illustration follows the vegetation zones along this part of Tromsa that was found relevant when presenting the species below that have Tromsa and surrounding areas as their habitat.



Lapwing, Yellowhammer, and Lynx are species living around Tromsa and are listed on the Norwegian list of vulnerable species living around Tromsa (Artsdatabanken, 2021). Otter was registered on the Norwegian list of vulnerable species until the year 2021 and still is categorized as vulnerable in parts of Europe (Eldegard et al., 2021). The white dipper, Norway's national bird, is characteristic of the landscape in and around Tromsa. And the beaver prefers landscapes with an open forest close to the water, preferably consisting of Birch, Goat willow, and Autumn spire in their habitat, to mention some. The beaver dams are usually excellent additions to rivers, as they also create habitats for many other species. In Norway and other parts of Europe, the beaver was near distinction in 1890 due to hunting for quality fur. It was then decided to protect the beaver, and the population has since then expanded to a healthy number (Bjerkely, 2018). The two fish species, Trout and Grayling, are native to Tromsa and Lågen. The dam's removal had a particularly positive effect on them as it allowed them to extend their habitat by migrating further upstream of Tromsa.



# Existing vegetation at the riparian zone

It is challenging for people to access the river and its shoulders within the canyon landscape. Here the vegetation is dense and thriving, and succession has climaxed. The pine trees dominate, competing for light, while some deciduous species are mixed in between. Downstream in the built-up areas, riparian zones have decreased. In some places, the zone is only a couple of meters wide, and vegetation consists mainly of shrubs and shorter plants.

Figure 54: Sections showing existing vegetation (Illustrations: Fjeldberg, I. 2022).

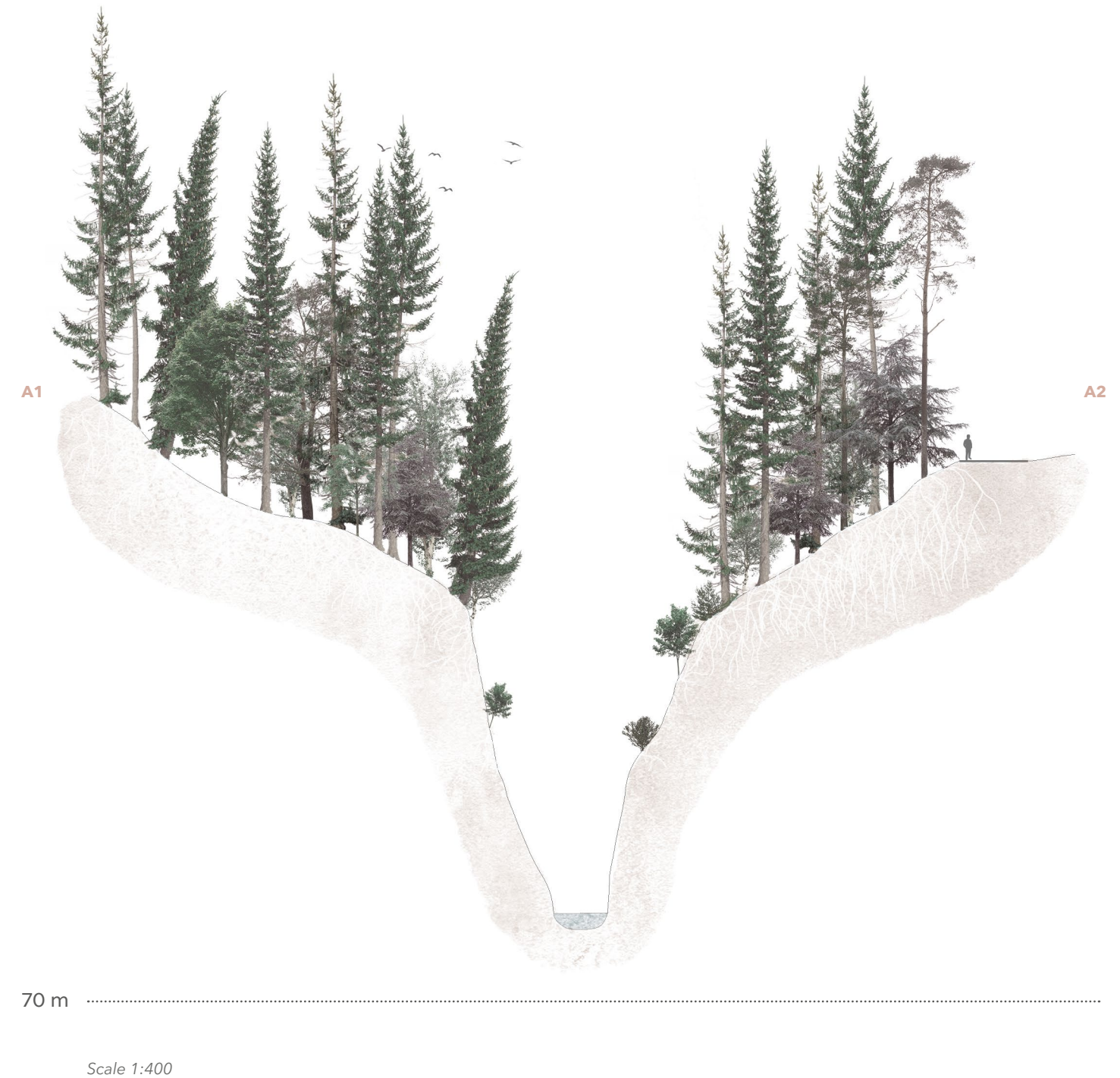
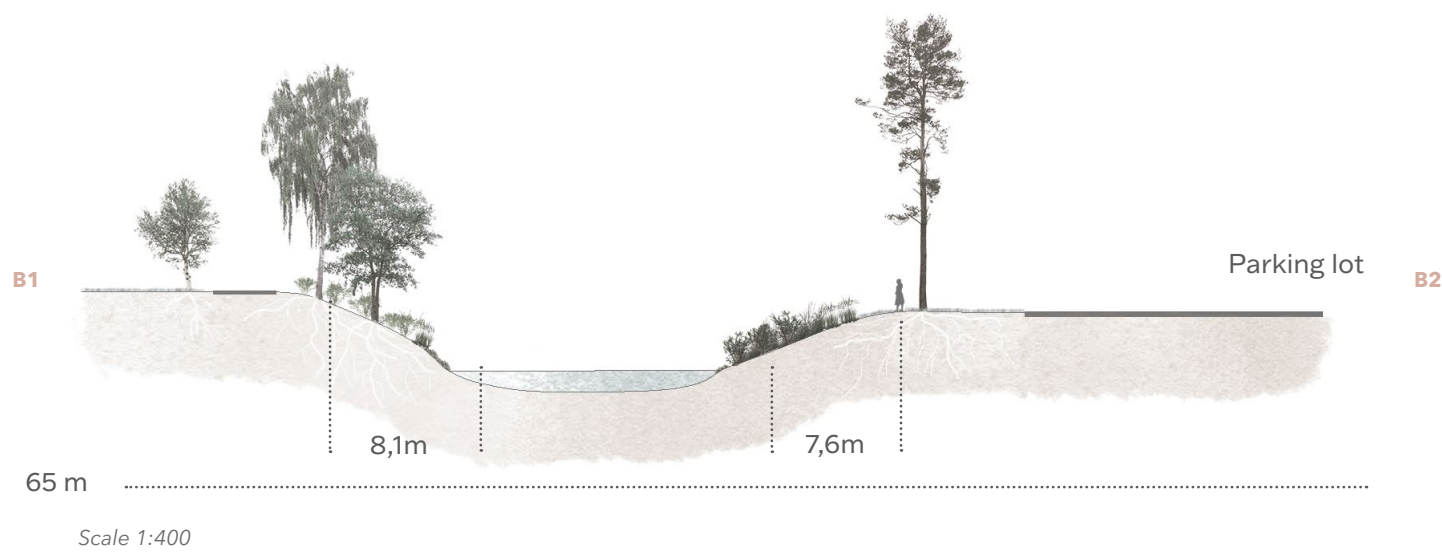
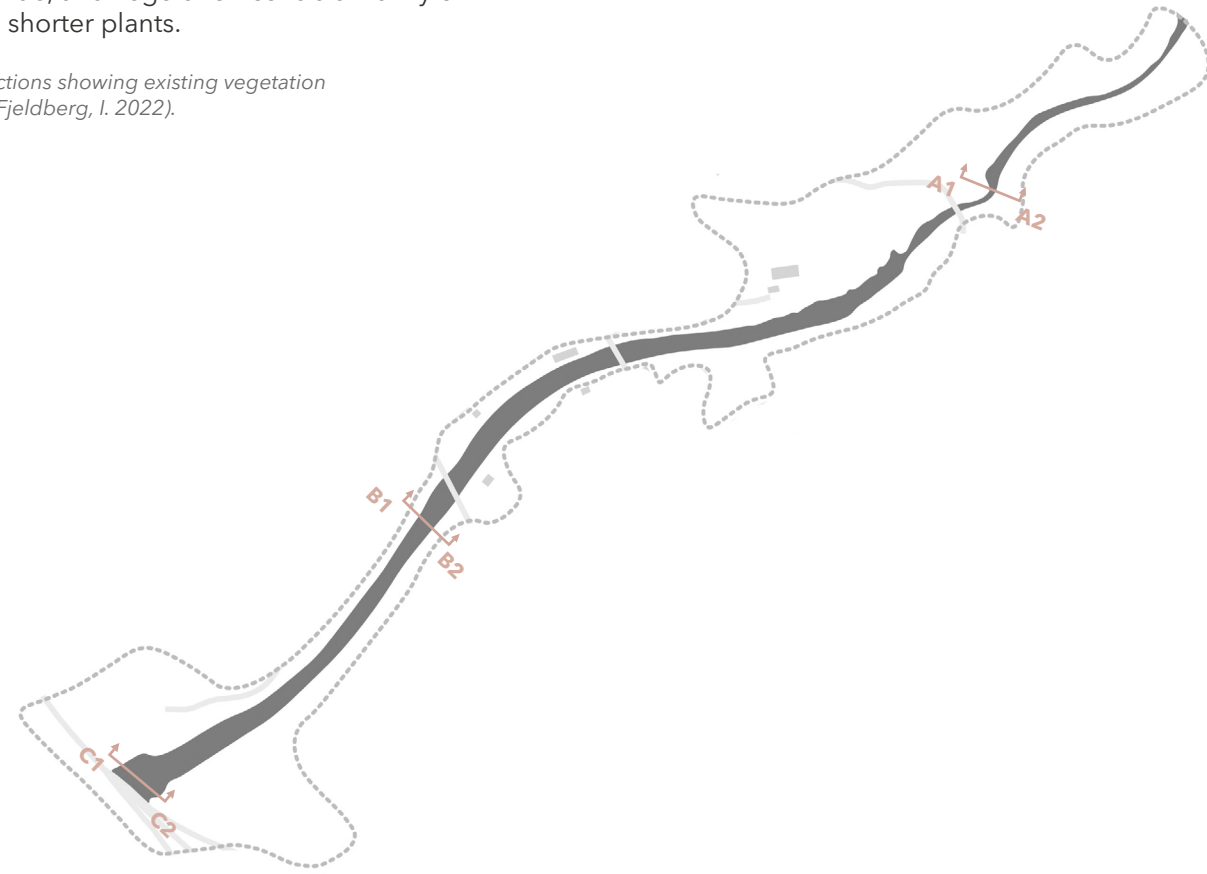





Figure 55a: Tromsa upstream of the dam, at the end of the Ice church trail (Photo: Fjeldberg, I. 2022).



Figure 55b: Squirrel in the forests of Fåvang (Photo: Fjeldberg, I. 2022).



# 4.3 Habitat for Trout and Grayling

Tromsa river has a direct ecological impact on Lågen at the geographic distance between Ringebu and Tretten. The fish species Trout and Grayling live in this part of Lågen and migrate to Tromsa for spawning. In Lågen, the river environment provides vital habitats for nutrition, reproduction, refuge, and migration routes. Fragmentation of habitats has resulted in a decline of trout and grayling in several parts of Europe. In Lågen, the populations of both species are very viable (Junge et al., 2014). This indicates ecological strength in this part of the river and underlines the importance of protecting the ecology here.

Figure 56a: Habitat of trout and grayling (map: Fjeldberg, I. 2022).

//// Habitat



Figure 56b: One of the habitat pools at the dam site (Photo: Fjeldberg, I. 2022).



# Trout

(*Salmo trutta*)



Figure 57a: Trout (Photo: Olsen, P. H.).

Tromsø is home to Trout, among several other species. This migratory fish swims up in rivers and streams for spawning when they mature. A newly hatched Trout will live in the gravel at the riverbed until the egg's nutrients are used up. Then, as the fish grows, the male will start to claim territory. The fish will spend the first two to five years of their life in the river and migrate downstream to a lake, a larger river, or the ocean. From Tromsø, they migrate to Lågen. At this time, the fish has reached a size of about 10-20 cm in length. The diet consists primarily of insects, but when the fish is big enough, it may also eat other smaller fish.

Most fish will migrate out from the river in the springtime, but a few migrate in the fall. The spawning period happens in the fall, between September and October. The timing depends on the water temperature; in some rivers, spawning may occur as late as December - January (Pethon, 2021).

During spawning, the female trout uses her fins to brush up gravel creating a small ditch for the eggs. The male trout then compete to fertilize the eggs, and the ditch will be covered by the female digging a new ditch upstream, which covers the eggs in gravel (Pethon et al., 2022). The size of the gravel is, therefore, an essential factor for suitable habitats. The size of the gravel is from the size of a pea to a walnut. Smaller fish need smaller gravel sizes, while bigger fish can handle bigger sizes, and bigger fish can use even bigger gravel. Another important factor when selecting a spawning area is that the stream has to be constant. The trout would never pick a site that may possibly dry out. The male trout guards the spawning area at nighttime and stay calm in the daytime (Pethon, 2021).

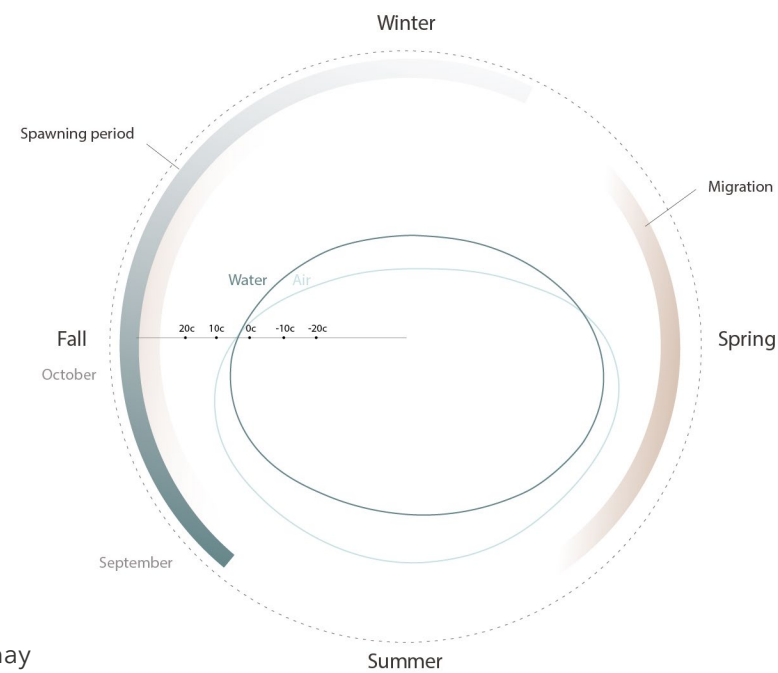

Figure 57b: Annual behavior, trout (Diagram: Fjeldberg, I. 2022).

# Grayling

(*Thymallus thymallus*)



Figure 57c: Grayling (Image source: Ristikent).

Another fish species that has river Tromsø as its habitat is the Grayling. It has the scent of the herb thyme, which is why it has the name *thymallus*, which means thyme in Latin. This species migrates up in the river for spawning, but in contrast to the trout, the spawning period is restricted to springtime between March - June. The male Grayling will dig a ditch approximately 4-8 cm deep for the female to lay the eggs, and the depth on this site is 0,2-4 meters. Grayling is a popular fish for anglers, but the meat must be prepared right after it has been caught, as it gets soggy quickly (Pethon, 2021). Migration happens mainly right before and after spawning, but bigger fish migrate seasonally to spend winter in deeper waters (Stewart et al., 2007).

The size of a mature fish is up to 60 cm, 3,5 kg in Norway, but usually a bit smaller. Diet contains plankton, insects, and crustation - when the fish is big enough. Grayling is highly selective regarding water quality, so if it is found in the waters, it is a good indicator of healthy water quality (Pethon, 2021).

Spawning happens in spring, in shallow water with gravelly substrata and shift velocities. The eggs hatch in early summer. The summer habitat selection for adult and juvenile fish varies more, but they tend to prefer the high velocity of the main river. In the autumn, they tend to migrate to deeper and slower pools in contrast to the summer sites (Nykänen et al., 2004).

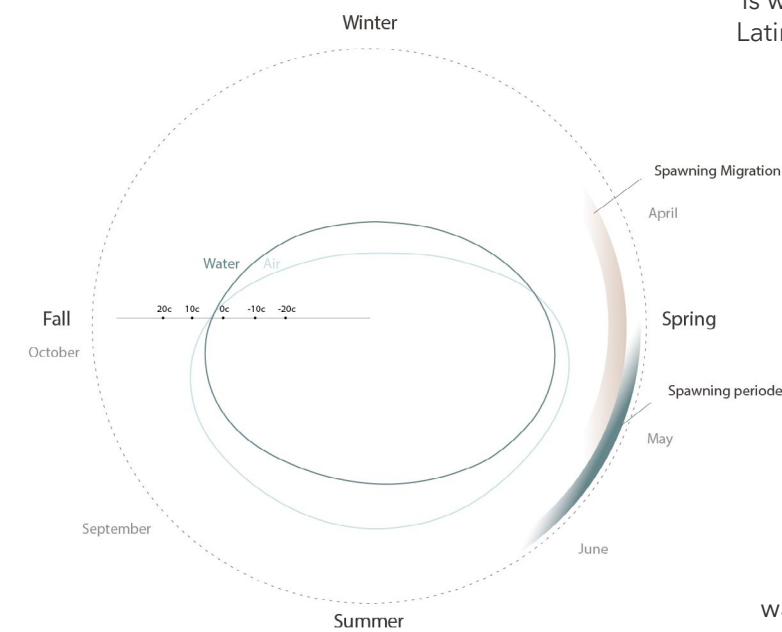

Figure 57d: Annual behavior, grayling (Diagram: Fjeldberg, I. 2022).



# 4.4 The status quo

Figure 58: Map of the existing situation. Scale on map is 1:2500 m (Map: Fjeldberg, I. 2022).

- Trails
- Existing trees



Rental cabins

Nesseskogen park

Mammuten Recreational area

Sports field

Tavern and gass station

Playground

Biketrack field

Remains of the dam

Area 1.

Area 2.

Area 3.

Area 4.

0 25 50 m



# Area 1.

Area 1. consists of the part of the river around the dam at Tromsa. The landscape opens up here, and the river formation is somewhat broader than other accessible parts of the river as the river transforms from a canyon landscape into a river delta further downstream. Surrounding buildings and infrastructure are not as visible from this site because of dense vegetation between the river and built areas. Here people go to look at the dam's waterfall, sit down and enjoy the river landscape, and maybe go down to the water. When the dam wall was present, there were small natural pools where it was possible to cool down in the summer. This is also where the habitat pools for the trout and grayling are constructed today. When you stand upon the High bridge, this area is what you are looking down at, facing west.

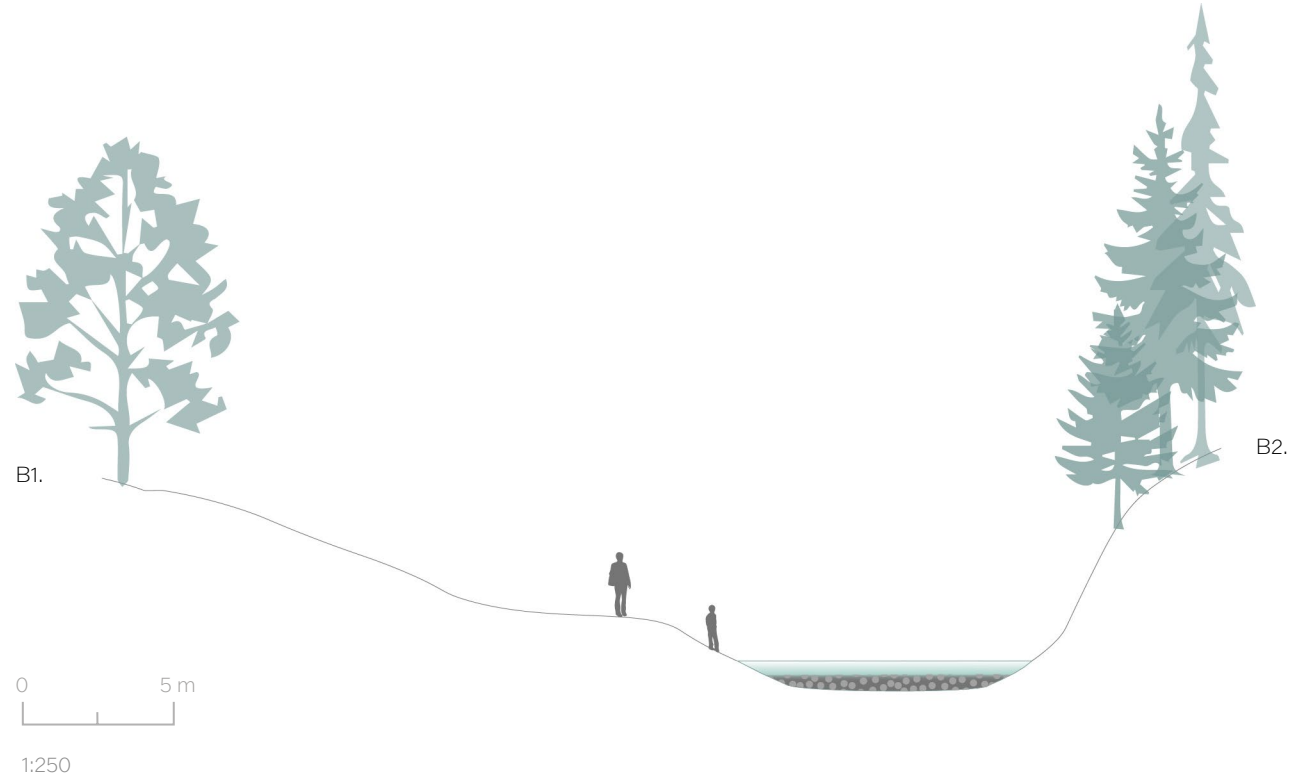
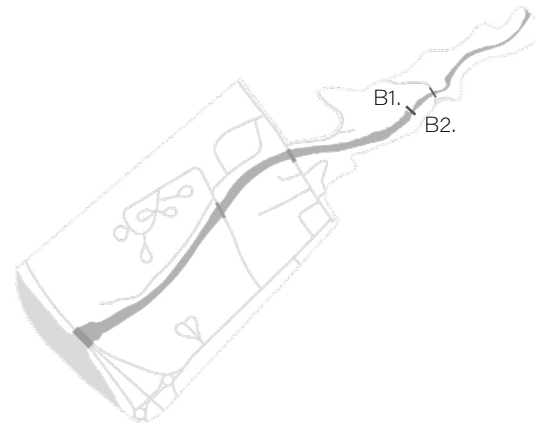

Figure 59a: Section B1-B2 (illustration: Fjeldberg, I. 2022).



Figure 59b: The dam site (Photo: Fjeldberg, I. 2022).



Figure 59c: Playfulness by the river (Photo: Fjeldberg, I. 2022).





Figure 59d: Section C1-C2 (illustration: Fjeldberg, I. 2022).





Figure 59e: View of Tromsa, with the temporarily constructed road that was washed away by the spring flood on the right (Photo: Fjeldberg, I. 2022).





Figure 59f: View towards the High bridge, into room 1, annotated in the map on page 114 (Photo: Fjeldberg, I. 2022).



Figure 59g: Top of the trail from the river side of Tromsa to the High bridge (Photo: Fjeldberg, I. 2022).



Figure 59h: The High bridge (Photo: Fjeldberg, I. 2022).



## Area 2.

The playground is close to the town center, with steep terrain and vegetation separating the space from Tromsa. Today the playground is equipped with traditional installations such as a swing, slide, balance training installations, and climbing wall.

On the other side of Tromsa, you find the Tromsnes farm. The riparian zone here is somewhat narrow due to the infrastructure. However, the landowner has built a wooden sidewalk to let people walk safely along the road from the town center to the dam site.

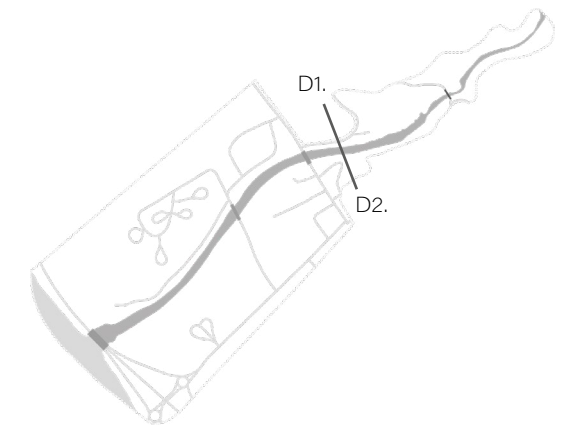

Figure 60a: Section D1-D2  
(illustration: Fjeldberg, I. 2022).



Figure 60b: Extended pedestrian walkway along Tromsa towards the dam site and the High bridge  
(Photo: Fjeldberg, I. 2022).



Figure 60c: The playground.  
(Photo: Fjeldberg, I. 2022).



# Area 3.

On the north side (left) of this area, you find the Tromsnes south farm. A road and a belt of vegetation separate the pastures from the river. Topology at the river sides becomes less steep here as we move further towards the river outlet. On the south side of Tromsa, you find the site that used to be Nessesaga, referring to the map on page 86. Today most of this space seems to be regarded as part of the garden area for the house built here, as the lawn is trimmed, and there are planted fruit trees. Fåvang town center owns the land on this side of the river, including the land the house in the south is on. A bridge over Tromsa connects the sites and is constructed south of the section shown below. The visitors of the cabin facility on the north side of the river also use this bridge. Walking north over the lawn, you will walk right into Nesseskogen park.

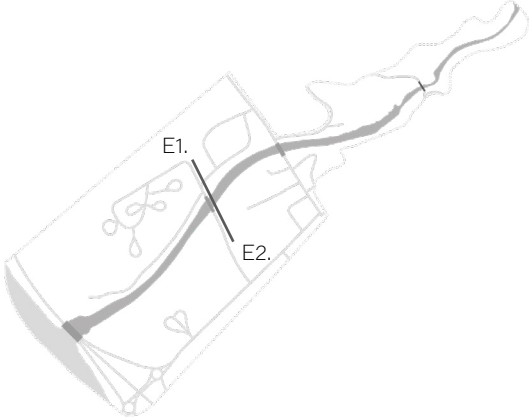

Figure 61a: Section E1-E2 (illustration: Fjeldberg, I. 2022).



Figure 61b: Facing north by the river. To the left, there is today a massive parking lot that was built after the image was taken (Image source: Google Street view, 2019).



Figure 61c: Nesseskogen park (Photo: Fjeldberg, I. 2022).



# Area 4.

We are located at the outlet of Tromsa, at the transition zone to Lågen. On the north side of the river, there is agricultural land and then an area of gravel before the riverside. The gravel was moved there to fill in the ground after it was dug out some years ago. The plan was to create a harbor for smaller boats here, but the land has been filled after changes in the plans. On the south side of Tromsa is a park named Mammuten recreational area, consisting of a big lawn and a constructed pond for kids to swim and play. Before we reach the road, two sports fields are on the corner of this park. This park is where the mammoth skull sculpture is located, refereeing to the map on page 138.

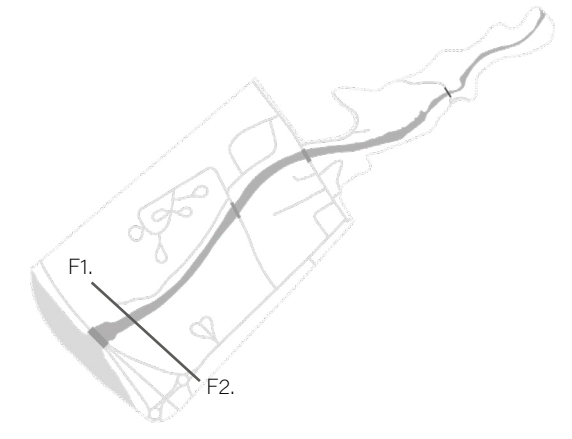

Figure 62a: Section F1-F2 (illustration: Fjeldberg, I. 2022).

Figure 62c: Mammuten recreational area (Photo: Fjeldberg, I.).

Figure 62b: View of Tromsa river and the site that has been filled with gravel (Image source: Google Street View, 2019).







Figure 62d: Recreational trail alongside Tromsa (Photo: Fjeldberg, I.).



Figure 62e: Stream from the swimming pond, to Tromsa (Photo: Fjeldberg, I.).

Figure 62f: Highway E6 at the outlet of Tromsa (Photo: Fjeldberg, I.).





# 4.5 Summarizing Analysis

## Accessibility and restoration potential

↔ River access fishing

↔ River access public

● Restoration potential

● Not easily accessible

▼ Dam

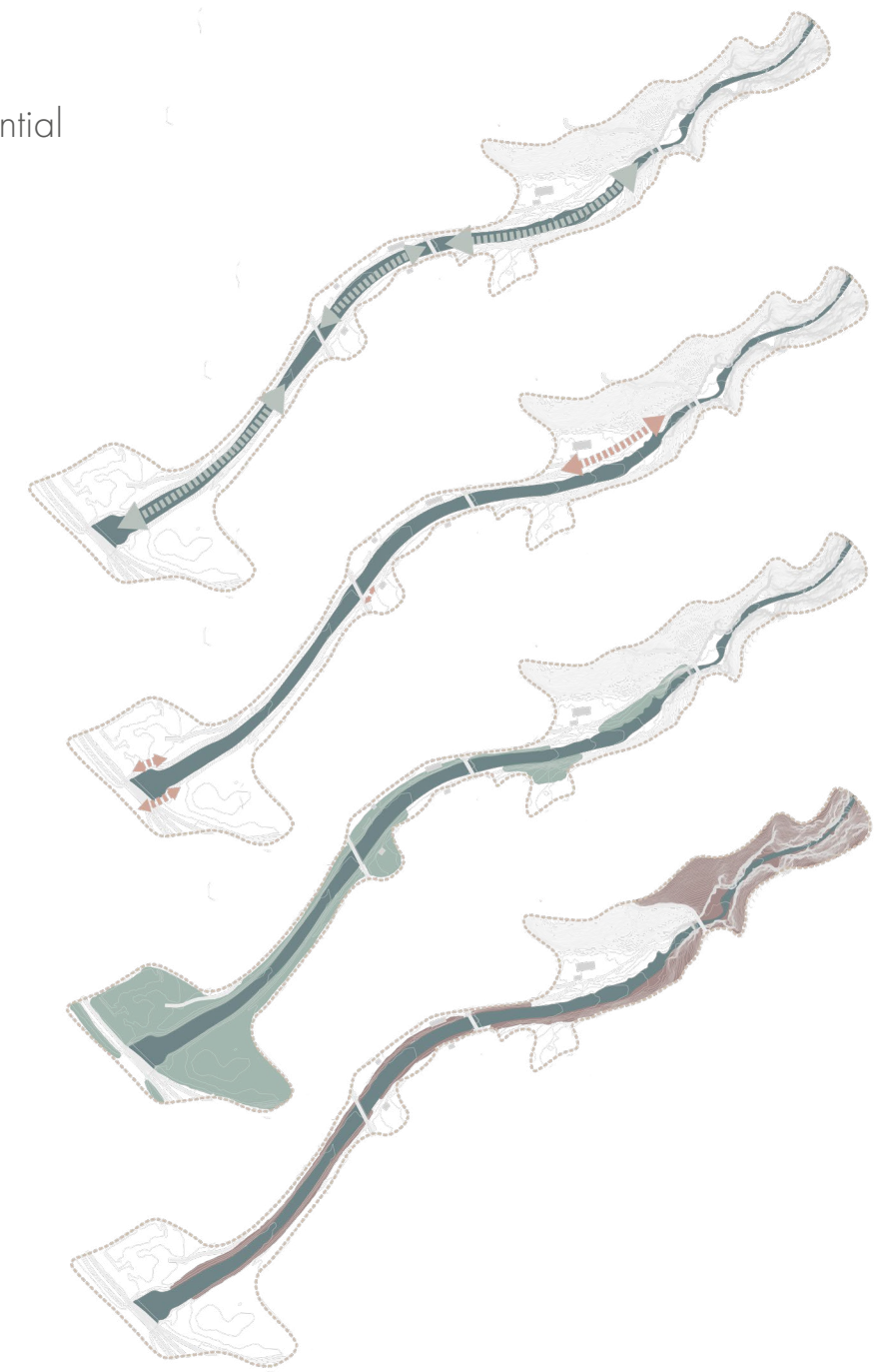

Figure 63a: Scale 1:10 000  
(diagram: Fjeldberg, I. 2022).



## Threats

The expansion of built areas, infrastructure, and agricultural development might be the greatest threat to the riverscape as it decreases riparian zones. This expansion also comes with extra noise barriers affecting wildlife and humans. Tourism areas as threats in this context are the cabins on the north side of the river Tromsa and the recreational area by the highway Europe road 6. Flooding may significantly threaten humans more than wildlife, as the rivers benefit from the flood, referring to the section on wetlands and river deltas (p.26). Moreover, the contaminants and pollution created by humans that may be traveling in flood water can be seen as a threat to the river concerning flooding.

Figure 63b: Threats summary maps  
(Diagram: Fjeldberg, I. 2022)

### Tourism

Tourist facilities



### Flood risk

200 year flood zone

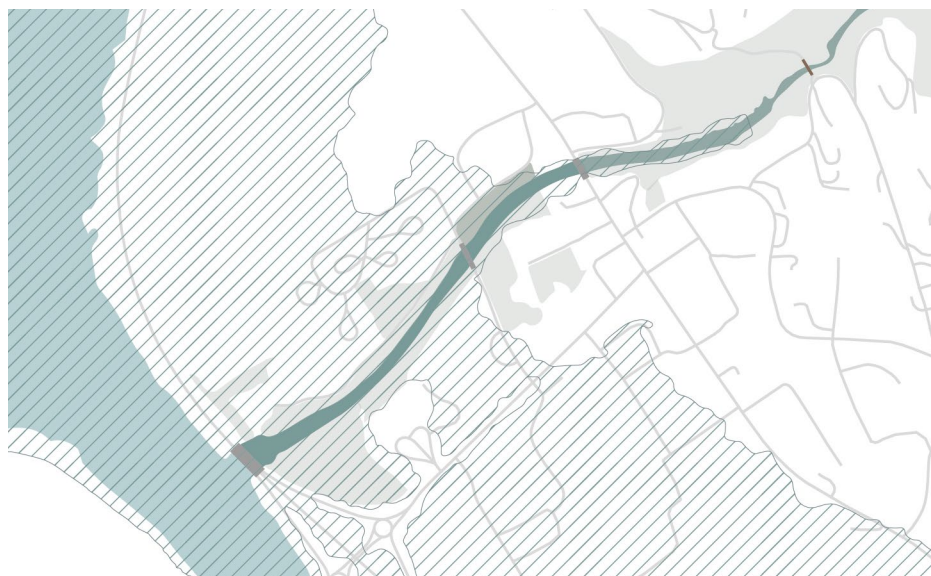

0 50m

### Agricultural expansion

Agricultural fields



### Noise

55-65 dB  
65 dB and higher



### Building and infrastructure expansion

built expansion



0 50m



## Effects of the dam removal in Tromsa - "modern SWOT"

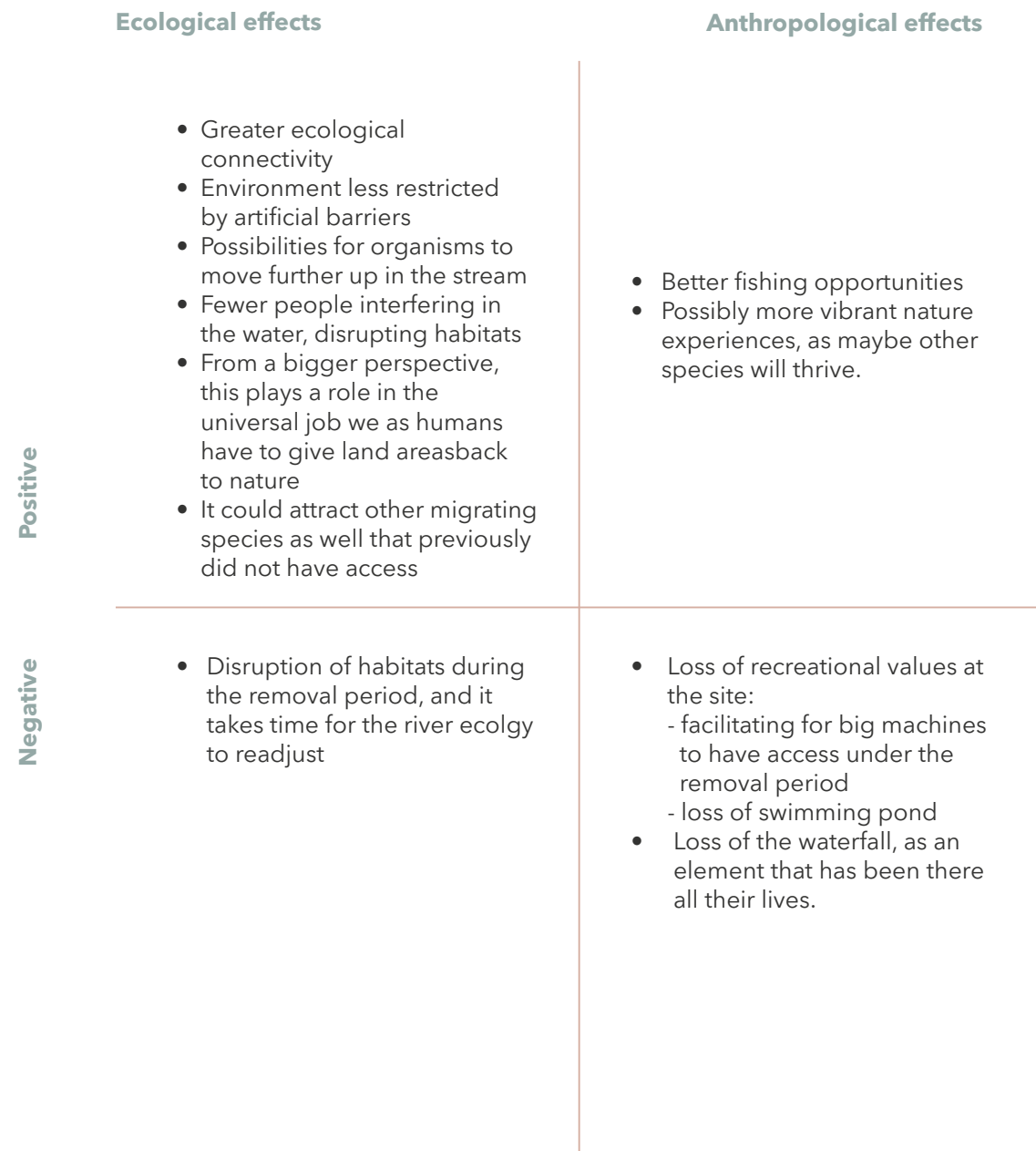

Figure 63c: Effects of the dam removal in Tromsa (Diagram: Fjeldberg, I. 2022).



# 5. Design



Figure 63d: Tromsa river (Photo: Fjeldberg, I. 2022).



# 5.1 Strategy map

Figure 64a: Scale on map is 1:2500 m  
(Map: Fjeldberg, I. 2022).

- Existing vegetation
- Revegetation
- Dynamic river movement
- Riparian zone - denser vegetated
- Wetland
- Stabilize soil with revegetation

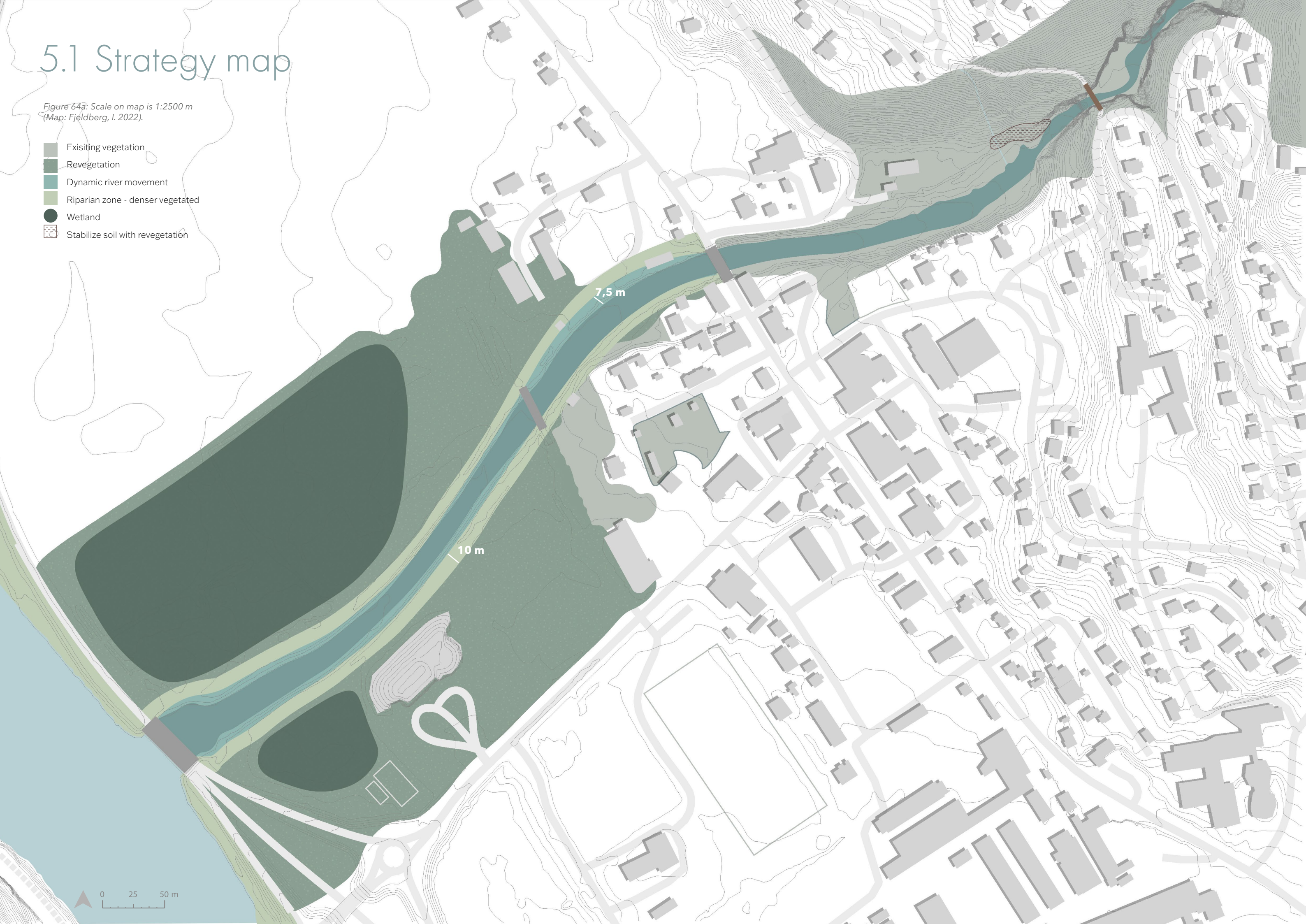



## Stabilize soil with vegetation

Below is an example of reconstructing the site with the constructed temporary road, as shown in the strategy map (figure 64a).

Figure 64b: Restabilization and prevent erosion (diagram: Fjeldberg, I. 2022).

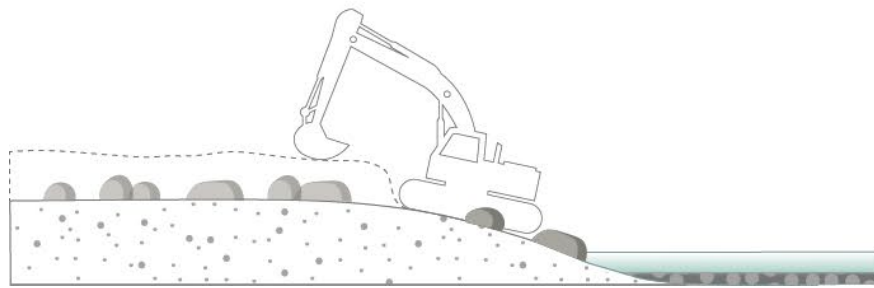

1. Stage: remove excessive soil, distribute it with an excavator, and shuffle.

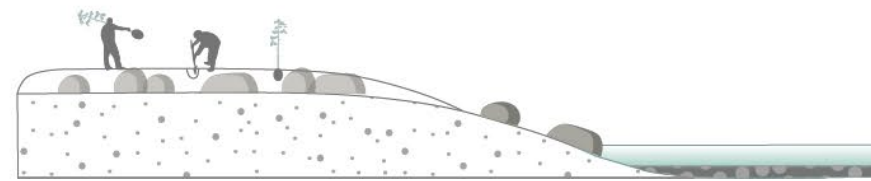

2. Stage: Plant trees, of the same species that are to be found native in the area.

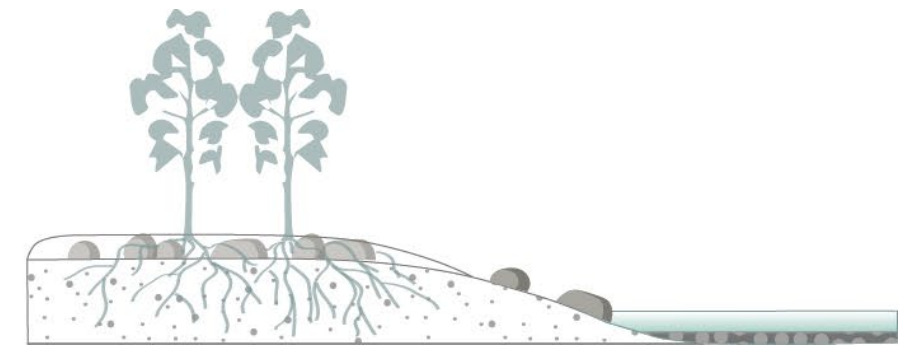

3. Stage. As the trees grow, the roots will stretch around rocks in the soil. The roots now hold the soil and stones together.

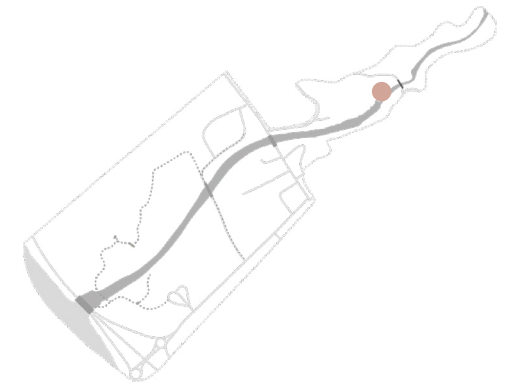

## Holiday cabins

It is suggested to move the holiday cabins on the north side of Tromsa to somewhere else. Preferably to a site that is not affected by any flood zones



## Information center

The tavern and gas station building may be transformed into an information center for water, wildlife, and biodiversity. This might be an excellent addition to education for schools and tourists and helps create awareness.

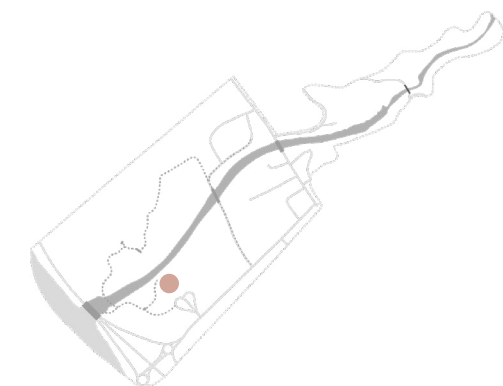



# 5.2 Proposal

Figure 65a: Scale on map is 1:2000 m  
(Map: Fjeldberg, I. 2022).

- Existing vegetation
- Seminatural meadow
- Wetland - seminatural wet meadow
- Wetland - marsh
- Dynamic river movement
- Trails - new
- Trails - existing
- Existing trees
- New trees and shrubs
- Perspective view



Information center:  
Water and biodiversity

G1.

G2.

0 25 50 m





Figure 65b: Section G1.-G2. Location is shown in the proposal map, figure 65a. (Illustration: Fjeldberg, I. 2022).

Meadow and wetland

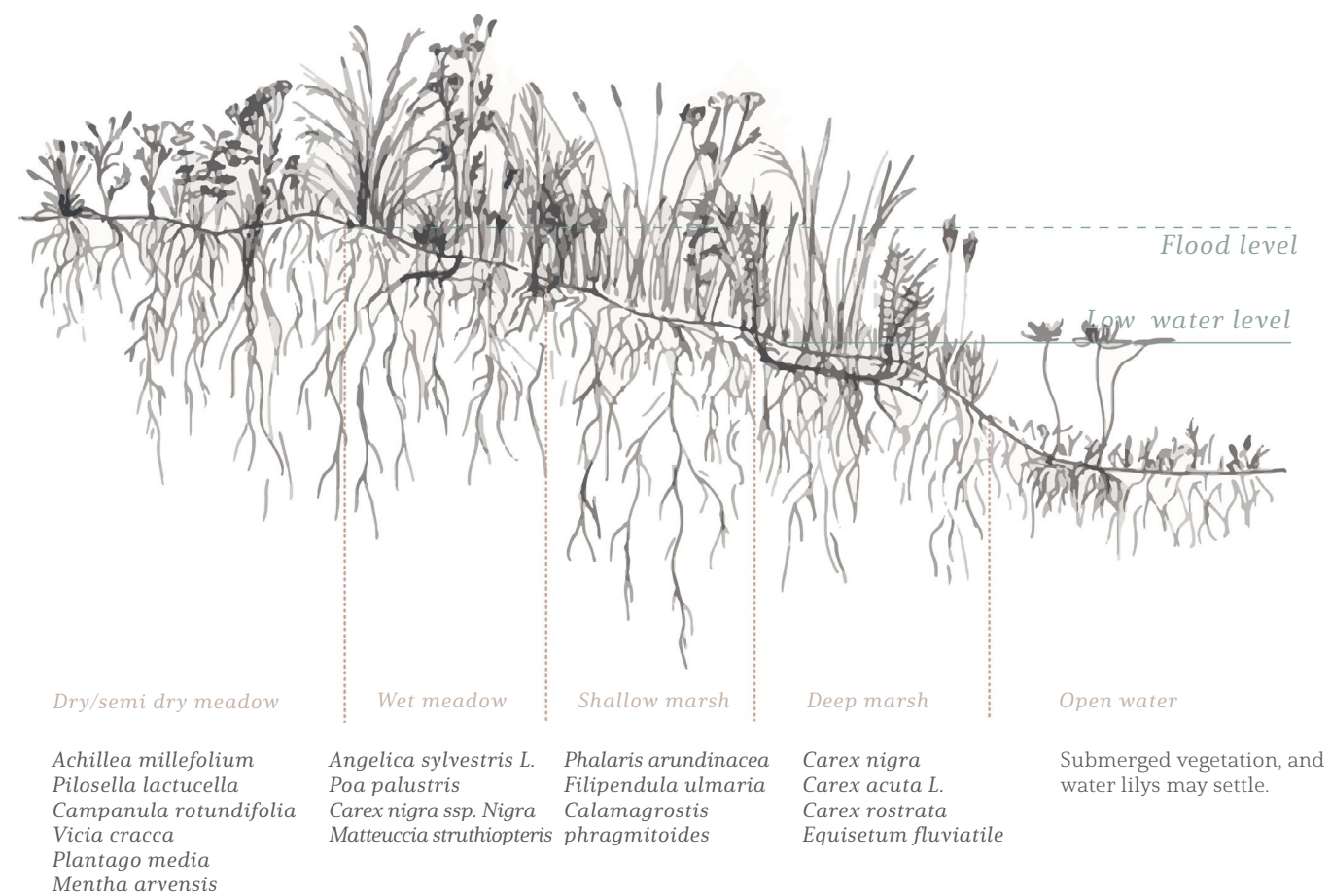

Figure 65c: Example of vegetation in meadows and wetlands (Illustration: Fjeldberg, I. 2022).

Riparian

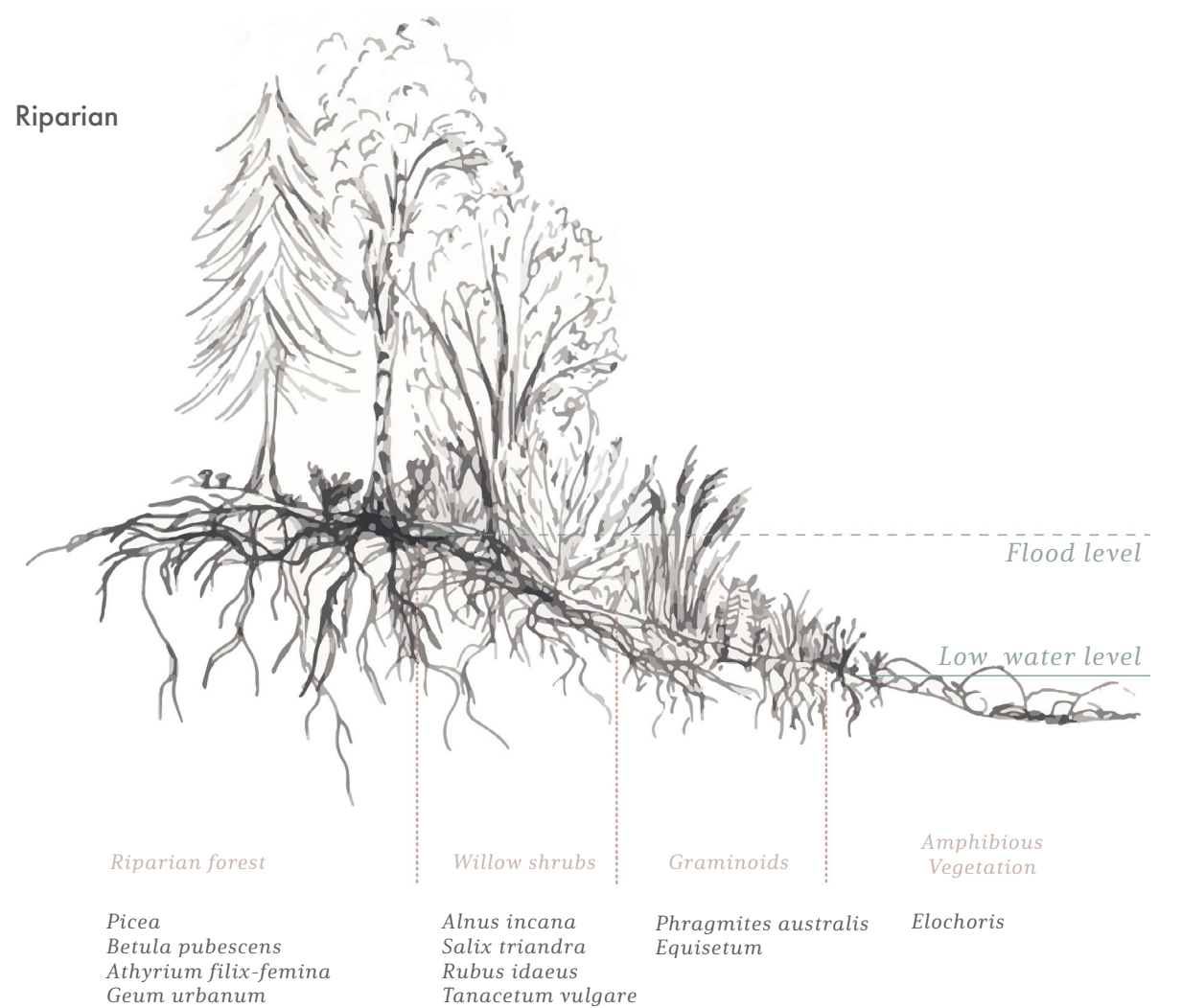
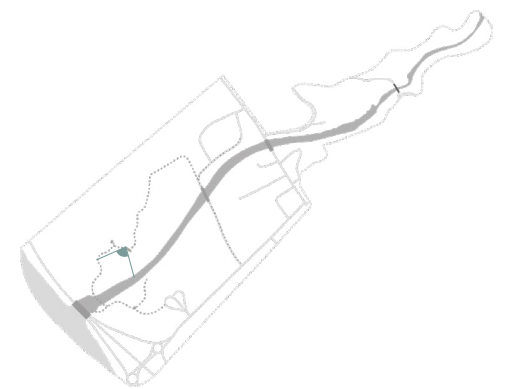

Figure 65d: Example of vegetation riparian vegetation (Illustration: Fjeldberg, I. 2022).





Figure 66: (Illustration: Fjeldberg, I. 2022).





### View onto the river

Figure 67a: (Illustration: Fjeldberg, I. 2022),

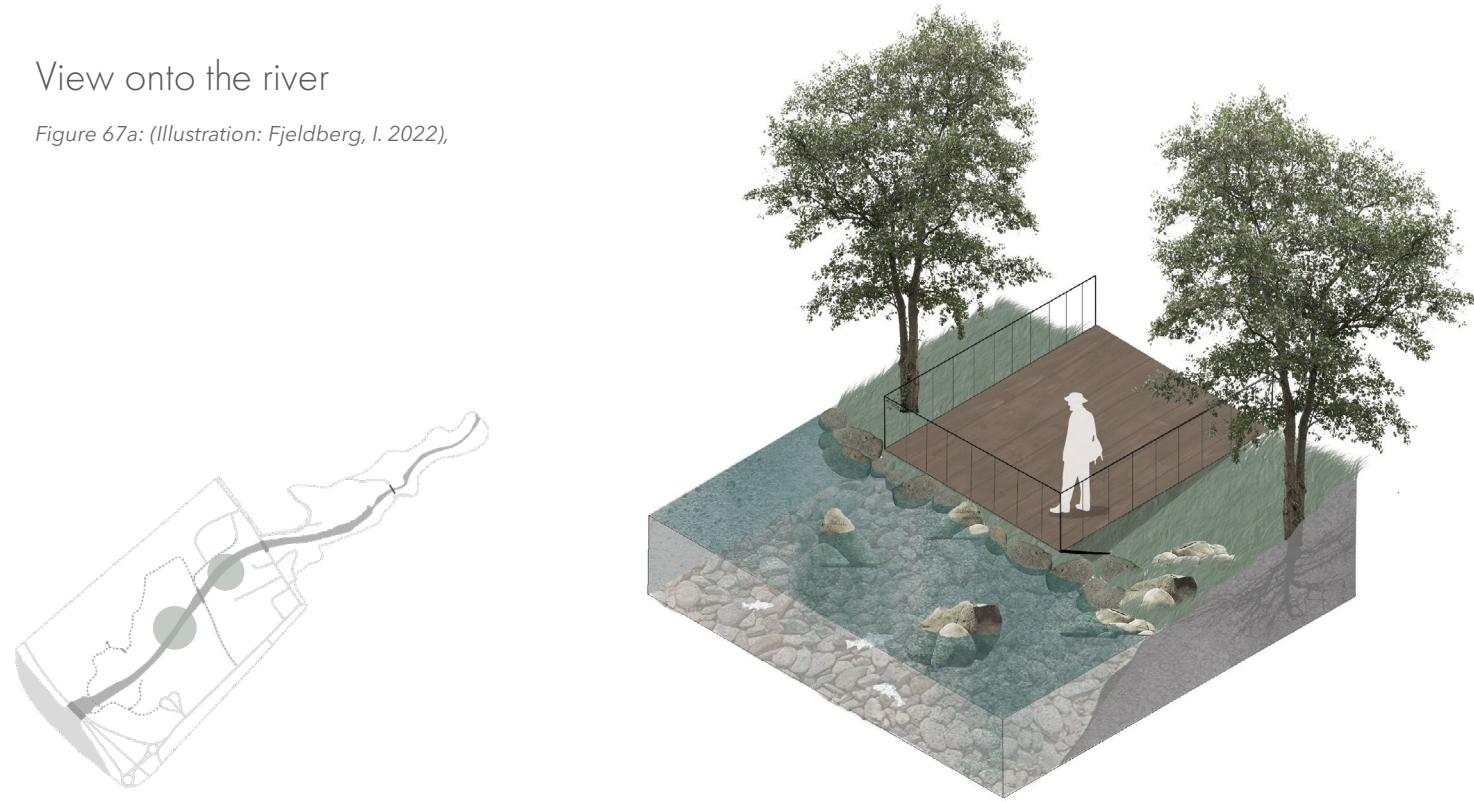

### Informal river crossings

Figure 67c: (Illustration: Fjeldberg, I. 2022),

There are no opportunities to use the stepping stones at high water levels.

At low water levels, the stepping stones may be an opportunity to play and to come closer to the water.

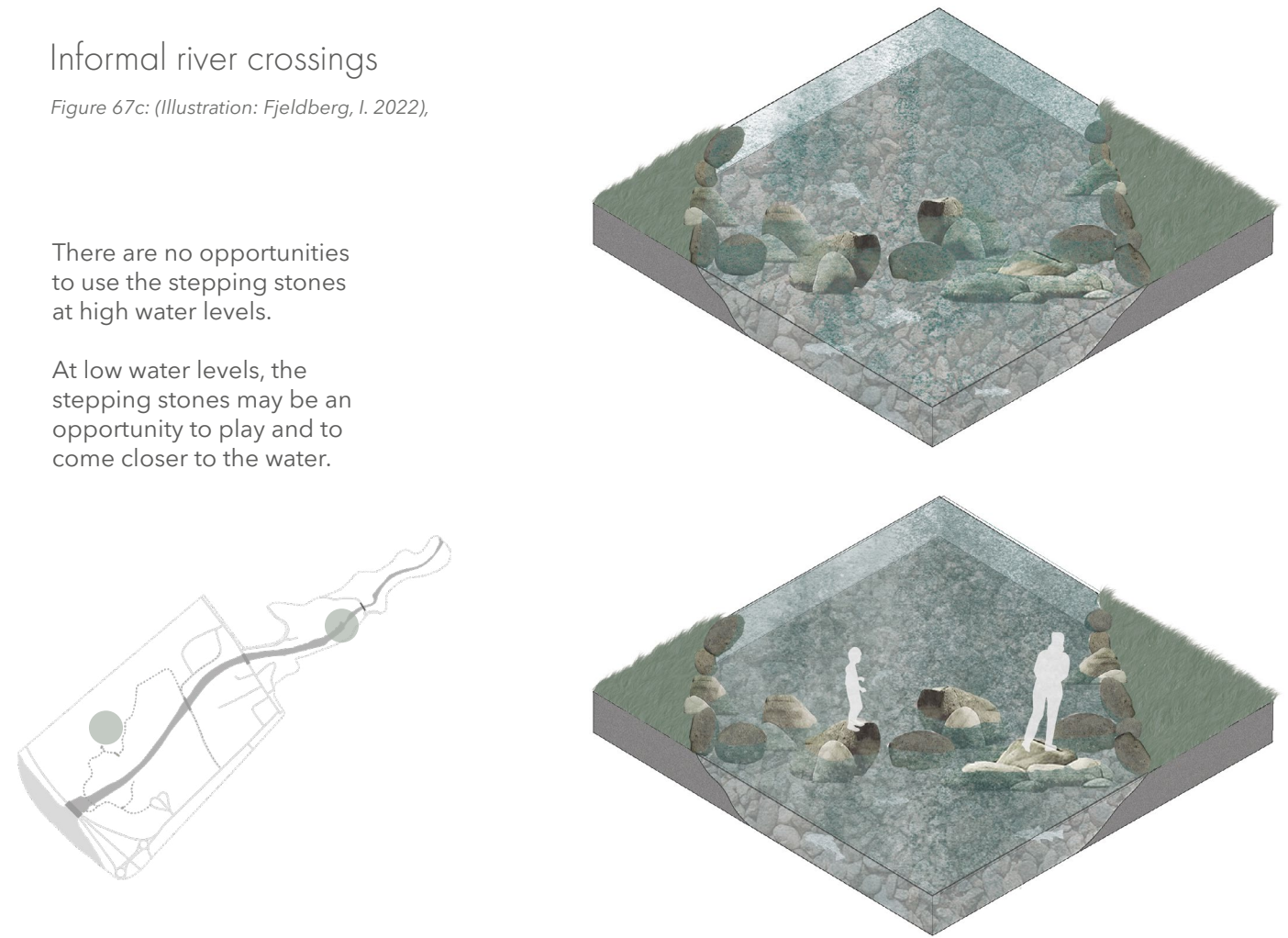

### Elevated path in the meadows

Figure 67b: (Illustration: Fjeldberg, I. 2022),

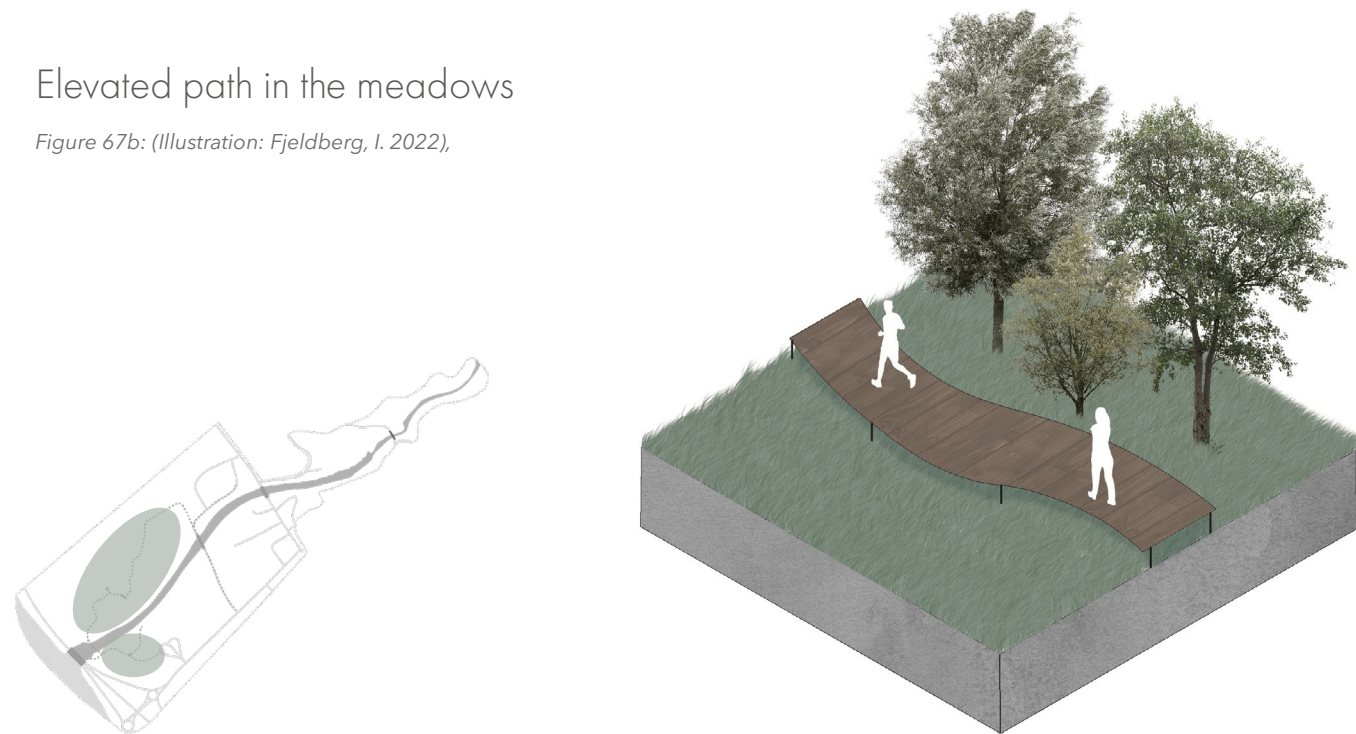

### Wildlife observation points

Figure 67d: (Illustration: Fjeldberg, I. 2022),

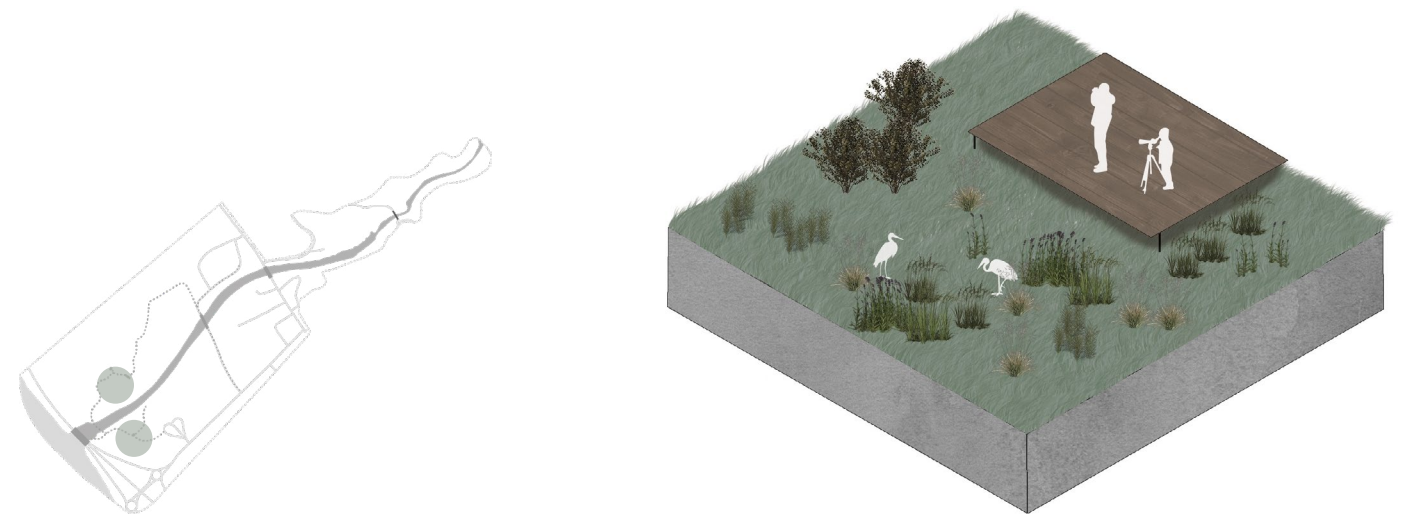



Pedestrian connectivity

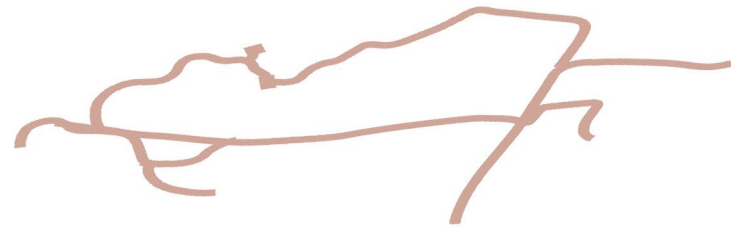

This network offers human stakeholders opportunities to visit the site and use it. Existing trails and proposed elevated paths may be used for recreational purposes and education. Boars can be placed with information about the wildlife at various locations.

Ecological connectivity  
– vegetation

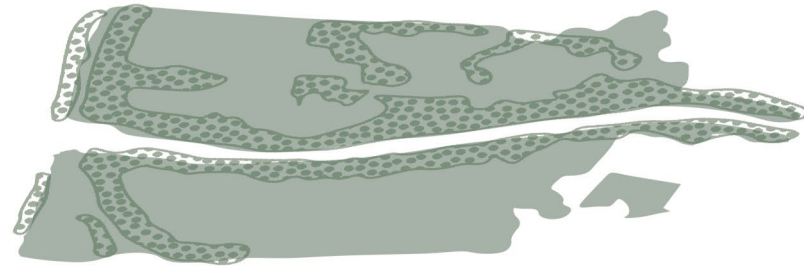

The trees, shrubs, and grasses in meadows have a network and will serve the river with more ecological energy. Mammals may use this landscape as a habitat, and pollinators and other insects that breed on land will also take advantage of it. In addition, birds may thrive in both the trees and on the ground

Wetland

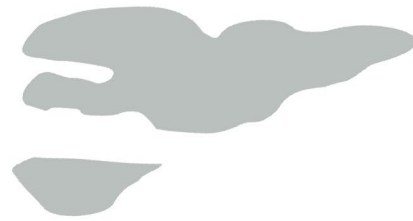

Wetlands may be home to insects and wetland birds and bind together vegetation and hydrology.

Ecological connectivity  
– Hydrology



Streams connecting wetlands and rivers into a network may improve the habitat of water-thriving organisms and fish. The fish will now have more opportunities to find suitable habitats for spawning and refuge. For example, when the water is high in Tromsa, they may swim into the wetland and find shallow waters with less current.

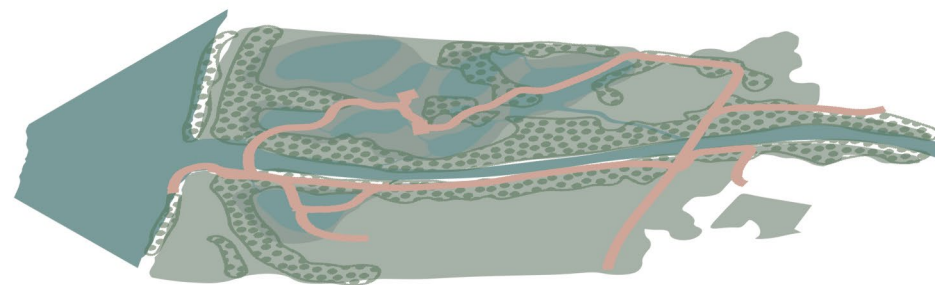



# Processes

## Continuous processes

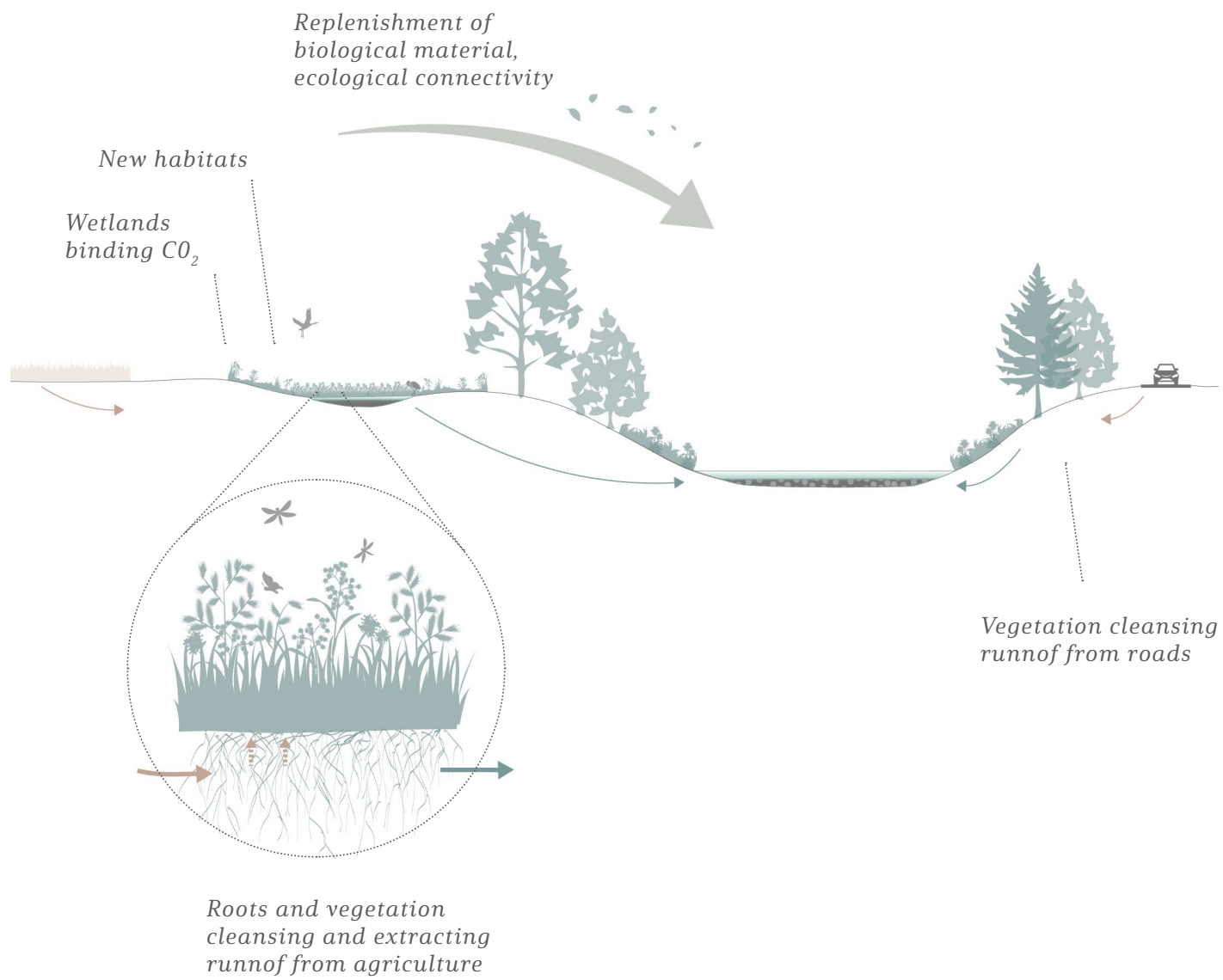

Figure 69a: Processes as a result of the proposal (Illustration: Fjeldberg, I. 2022).

## Flooded landscape

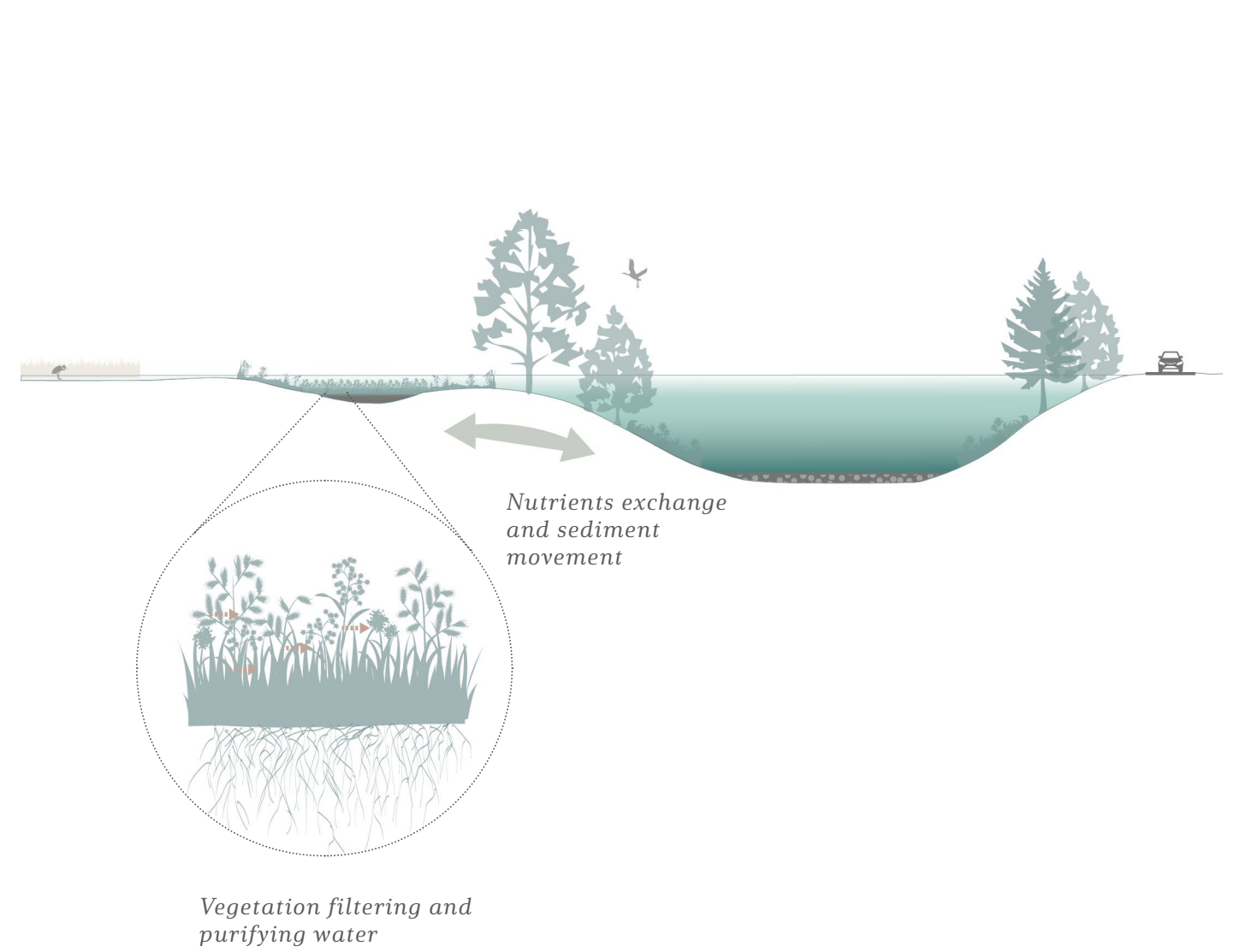

Figure 69b: Processes as a result of the proposal in flooded periods (Illustration: Fjeldberg, I. 2022).



## Benefits for the Trout and the Grayling

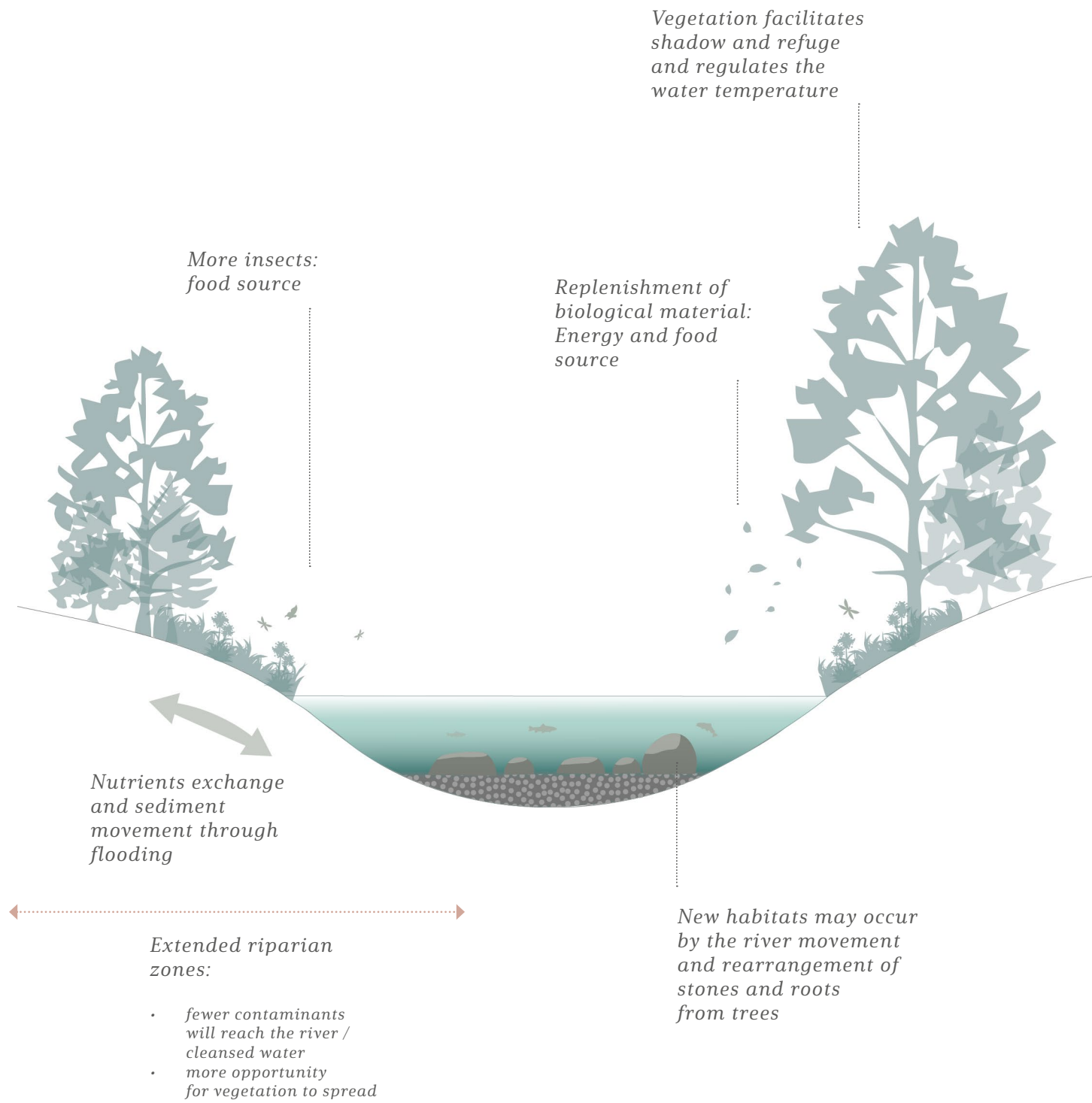

Figure 69c: Benefits for the trout and grayling (Illustration: Fjeldberg, I. 2022).



Figure 69d: The habitat pools are set to be reconstructed as part of the dam removal project (Photo: Fjeldberg, I. 2022).



# Vegetation gradientns

## Wetland

It is suggested to reconstruct wetlands within the flood zones combined with dryer meadows as an extension of the riparian vegetation.

## Seminatural wet meadow

This landscape type surrounds the marshland and will be flooded periodically. It contains more water than the seminatural meadow but is primarily dry enough for pastures to be present and keep the vegetation at a certain height. Species growing here are primarily smaller to medium size plants dominated by grass species and herbs (Artsdatabanken, no date-b).

## Marsh

These areas may be as broad and deep enough that they will look like ponds with open water surfaces when there is a high presence of water. The gradient zones with some selected plants are shown in the illustration on page 170, and medium and tall grass species dominate the vegetation.

As for the vegetation surrounding the marsh, it is suggested to facilitate seminatural wet meadow and seminatural meadow. Grazing pastures may maintain these landscape types to prevent further succession. It is recommended to use cattle, as they leave some of the vegetation, in contrast to sheep or goats (Norderhaug & Isdal, 1999).

## Seminatural meadow

In the remaining areas surrounding the wetlands, it is suggested natural succession of revegetation. The vegetation here is predicted to be categorized as a seminatural meadow. The flora here consists of grasses, herbs, mosses, and mushrooms. Nutrients are added by natural processes such as weathering, runoff from stormwater, nitrogen-binding bacteria, mycorrhiza, and algae (Artsdatabanken, no date-a). As with the wet meadow, grazing animals are recommended to maintain this meadow type well

## Riparian zones - denser vegetated

To further increase the benefits of riparian forest vegetation, it is proposed to let the vegetation thrive and allow more vegetation, like trees and shrubs, to settle here. In these zones, the vegetation is a mix of trees, shrubs, grasses, herbs, and other smaller plants. This will facilitate more organic material falling into the water and other benefits listed in the chapter Riparian vegetation (p. 23). In addition, more trees and shrubs will function as a visual barrier and, to some extent, as a sound barrier from highway E6. The vegetation will also collect dust and contaminants from the traffic.

## Trees and shrubs

In the riparian zones, in the seminatural meadows, and occasionally in the seminatural wet meadows, water-tolerant trees such as *Alnus incana*, *Prunus padus*, *Salix triandra*, and *Salix daphnoides subsp. Daphnoides* may settle. This is in addition to the registered species at the site today.

The selected categories and descriptions of the vegetation zones and the plants suggested in Figures 65c and 65d have been chosen by analyzing the nearby wetland vegetation shown on the map on (figure 31) page 91 (Miljødirektoratet, 2011; Miljødirektoratet, 2012a; Miljødirektoratet, 2012b) and information from Artsdatabanken (Artsdatabanken, no date-a; Artsdatabanken, no date-b), combined with research of other similar vegetation types around Lågen and in Fåvang (Fylkesmannen i Sør-Trøndelag, 2014), together with the information gathered at site visits. Therefore, all the plants are native, and only species that are not invasive or alien species are mentioned. The vegetation types provide habitat for insects, birds, small mammals, and organisms in the water. In addition, they all contribute to improving and maintaining water quality in the rivers.



## River scape

### Dynamic river movement

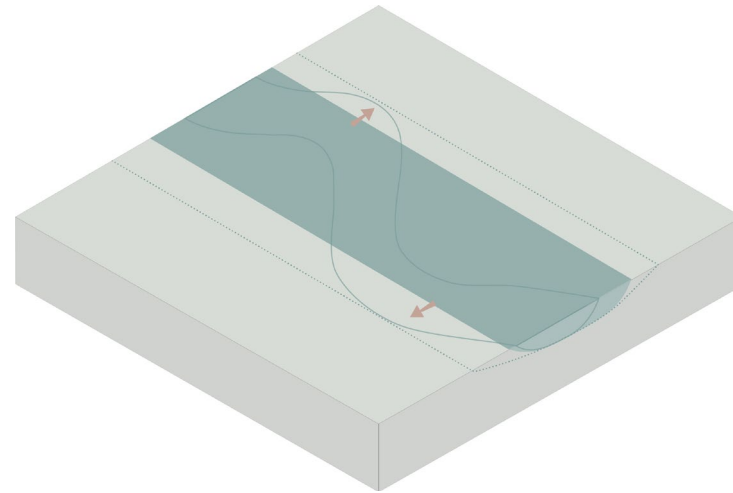

With extended side areas, the river will have more space to move. The shape may then transition naturally following environmental processes. Facilitating the river to stretch out in streams into the wetlands also opens opportunities for new essential habitats for migrating fish. A significant part of this habitat type has disappeared from Lågen and its tributaries in favor of agriculture, infrastructure, and industry (Fylkesmannen i Sør-Trøndelag, 2014).

Figure 70a: River movement (Illustration: Fjeldberg, I. 2022).

## Riparian vegetation

### SucceSSION

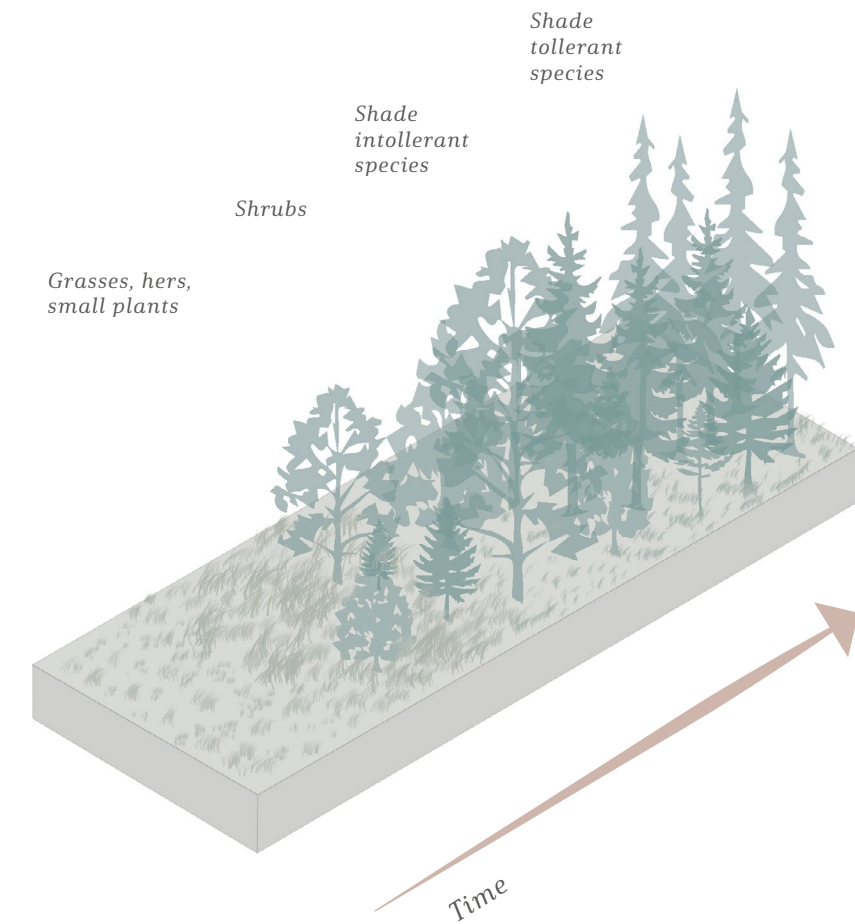

Vegetation will evolve where there is proposed natural succession unless grazing animals will use these areas. Then, different species will compete for space, and their appearance will change yearly. Preferably, the vegetation not maintained by grazing animals will evolve and grow old.

Figure 70b: Succession (Illustration: Fjeldberg, I. 2022).



## 5.3 Conclusion and reflection

### Conclusion

This project evolved around the selected site at the Tromsa river, where the dam was partly removed in January 2022. I have been working towards answering the research question: *In what ways can we sustainably restore a riverscape after dam removal?*

This thesis has looked at a time perspective that stretches further back than right before the dam's removal, as industrialization, with expanded infrastructure and competing agriculture, has been a significant game changer in how we use our natural resources. The past and present landscape has been observed, and then research has been done on what might be most beneficial for the river, the migrating fish species that have the river as their habitat, and the surrounding wildlife. This conclusion evolved through site visits, analyses, and reading relevant literature: By restoring riverscapes to more natural environments, we benefit biodiversity and adapt to climate change by avoiding severe flooding of the built areas and infrastructure.

The thesis illustrates that humans often manage natural resources in a way that may be negative for nature and wildlife. Perhaps there is a need to take land areas and give them back to the wilderness. Restoring the site to a similar state that previously existed, with similar surrounding wetland landscapes, would be more healthy for the river and the connecting ecosystems than to continue facilitating with mainly anthropological interests. But to make such changes last, the human stakeholders must also accept and embrace these changes. They need opportunities to use the site and to feel connected to it. Therefore along with the new trails, it is proposed ideas that may be implemented for humans, which allow them to use the site and get a feeling of connection without too much negative impact on nature.

Although landscape architecture is interdisciplinary, one must be able to work with other relevant fields to specialize in topics we work on to serve nature as best as possible. Examples, such as ecologists and hydrologists, will be essential colleagues in our work on designing sustainable landscapes. Broader knowledge of this topic at a local scale early might be a great addition. If kids learn about the local species and what threatens them, linking it to a global perspective, and creating an understanding and connection early in life, maybe that will help prevent the same anthropogenic use of nature in the future.

In December 2022, United Nations gathered leaders from all over the world to sign the new closure of ending and reversing the loss of nature within 2030. They decided that 30% of demolished nature shall be restored by that time (United Nations, 2022). I hope this proposal can be seen as a step in the right direction and that we will see more in the years to come.

The proposal was landed on a solution of taking nature back. The way we have used nature as a resource has become too overwhelming, and nature types are disappearing as the climate changes, making it hard for nature to keep up and adapt at this speed. While nature and wildlife can adapt to a limited extent to our management of landscapes, humans can more easily choose to adapt to nature's processes. Ultimately, we are all part of the exact nature and interconnected, but humans have been pushing nature's limits for a long time. It is time for us to change our mindset and cooperate with nature.

### Reflection

Working on this thesis has been exciting and engaging, and I have gained a lot of new knowledge to bring with me. In addition to new knowledge about ecology, I have learned more about the fact that stakeholders often want to preserve elements such as decommissioned dams, which was a bit surprising to me, and I believe this is valuable knowledge too. I was already interested in waterscapes and nature restoration, but this interest has grown stronger after working on this thesis. I started this project by focusing mainly on the site around the dam, but later in the process, I learned that I should shift my focus and concentrate more on the area around the river outlet. This is because the outlet is an important area for the river, and I became aware of the lost wetland areas and delta landscape. At first, this was a bit challenging, primarily because of the massive changes I was about to propose. But it felt right to make sustainable changes that would affect more of the global picture. Ideally, if there were more time and the context was somehow different, I would also like to engage the stakeholders more in the process.

Another challenge has been writing such an extensive document in English. I have written many assignments in English, but I met some frustrating moments with my texts here. Though I have learned from that, and I am hopefully better suited for international professional communication after this semester.



# 6. Bibliography

## References

- Algera, D. A., Rytwinski, T., Taylor, J. J., Bennett, J. R., Smokorowski, K. E., Harrison, P. M., Clarke, K. D., Enders, E. C., Power, M., Bevelhimer, M. S., et al. (2020). What are the relative risks of mortality and injury for fish during downstream passage at hydroelectric dams in temperate regions? A systematic review. *Environmental Evidence*, 9 (1): 3. doi: 10.1186/s13750-020-0184-0.
- AMBER. (2022). *AMBER Barrier Atlas*. Available at: <https://amber.international/>.
- American Rivers. (no date). *How dams are removed*. Available at: <https://www.americanrivers.org/threats-solutions/restoring-damaged-rivers/how-dams-are-removed/> (accessed: 07.11.2022).
- Andreoli, A., Chiaradia, E. A., Cislighi, A., Bischetti, G. B. & Comiti, F. (2020). Roots reinforcement by riparian trees in restored rivers. *Geomorphology*, 370: 107389. doi: <https://doi.org/10.1016/j.geomorph.2020.107389>.
- Armstrong, J. D., Kemp, P. S., Kennedy, G. J. A., Ladle, M. & Milner, N. J. (2003). Habitat requirements of Atlantic salmon and brown trout in rivers and streams. *Fisheries Research*, 62 (2): 143-170. doi: [https://doi.org/10.1016/S0165-7836\(02\)00160-1](https://doi.org/10.1016/S0165-7836(02)00160-1).
- Arsénio, P., Rodríguez-González, P. M., Bernez, I., S. Dias, F., Bugalho, M. N. & Dufour, S. (2020). Riparian vegetation restoration: Does social perception reflect ecological value? *River Research and Applications*, 36 (6): 907-920. doi: <https://doi.org/10.1002/rra.3514>.
- Artsdatabanken. (2021). *Norsk rødliste for arter 2021*. Available at: <https://www.artsdatabanken.no/lister/rodlisterforarter/2021> (accessed: 02.12.2022).
- Artsdatabanken. (2022). *Artskart*. Available at: [https://artskart.artsdatabanken.no/app/#map/243772,6822964/14/background/greyMap/filter/%7B%22IncludeSubTaxonIds%22%3Atrue%2C%22Found%22%3A%5B%2D%2C%22NotRecovered%22%3A%5B%2D%2C%22BoundingBox%22%3A%22POLYGON%20\(\(242923.30672924887%206822430.925999635%2C244621.09579174887%206822430.925999635%2C244621.09579174887%206823497.99435901%2C242923.30672924887%206823497.99435901%2C242923.30672924887%206822430.925999635\)\)%22%2C%22Style%22%3A1%7D](https://artskart.artsdatabanken.no/app/#map/243772,6822964/14/background/greyMap/filter/%7B%22IncludeSubTaxonIds%22%3Atrue%2C%22Found%22%3A%5B%2D%2C%22NotRecovered%22%3A%5B%2D%2C%22BoundingBox%22%3A%22POLYGON%20((242923.30672924887%206822430.925999635%2C244621.09579174887%206822430.925999635%2C244621.09579174887%206823497.99435901%2C242923.30672924887%206823497.99435901%2C242923.30672924887%206822430.925999635))%22%2C%22Style%22%3A1%7D) (accessed: 19.10.2022).
- Artsdatabanken. (no date-a). *T32 Semi-naturlig eng*. Available at: [https://www.artsdatabanken.no/Pages/171950/Semi-naturlig\\_eng](https://www.artsdatabanken.no/Pages/171950/Semi-naturlig_eng) (accessed: 10.12.2022).
- Artsdatabanken. (no date-b). *V10 Semi-naturlig våteng*. Available at: [https://www.artsdatabanken.no/Pages/171972/Semi-naturlig\\_vaateng](https://www.artsdatabanken.no/Pages/171972/Semi-naturlig_vaateng) (accessed: 12.12.2022).
- Bechmann, M., Thrane, J. E., Kværnø, S. & Turtumøygard, S. (2021). *Eutrofiering av Mjøsa - kartlegging av årsaksforhold og kilder til fosfor i delnedbørfelt: Gudbrandsdalslågen*. NIBIO POP 13/2021. Available at: [https://nibio.brage.unit.no/nibio-xmlui/bitstream/handle/11250/2734723/NIBIO\\_POP\\_2021\\_7\\_13.pdf?sequence=1&isAllowed=y](https://nibio.brage.unit.no/nibio-xmlui/bitstream/handle/11250/2734723/NIBIO_POP_2021_7_13.pdf?sequence=1&isAllowed=y).
- Bellmore, J., Pess, G., Duda, J., O'Connor, J., East, A., Foley, M., Wilcox, A., Major, J., Shafroth, P., Morley, S., et al. (2019). Conceptualizing Ecological Responses to Dam Removal: If You Remove It, What's to Come? *BioScience*, 69: 26-39. doi: 10.1093/biosci/biy152.
- Bergeron, R. (2022, November 13.). Rivers are drying up, but it's not too late to help. Here's where to start. *CNN*. Available at: <https://edition.cnn.com/2022/11/11/us/iyw-how-to-help-our-rivers/index.html> (accessed: 15.11.2022).
- Bjerkely, H. J. (2018). *Norske naturtyper - Økologi og mangfold*. 2nd ed. Oslo: Universitetsforlaget.
- Bjerknessenteret. (2015). The Gulf Stream and our mild climate in Norway. Available at: <https://bjerknes.uib.no/en/article/ipcc/gulf-stream> (accessed: 08.12.2022).
- Casanova, M. T. & Brock, M. A. (2000). How do depth, duration and frequency of flooding influence the establishment of wetland plant communities? *Plant Ecology*, 147 (2): 237-250. doi: 10.1023/A:1009875226637.
- Catlett, K. (2022). *The Impact of Hydropower Revealed*. Available at: [https://www.americanrivers.org/2022/08/methane-admissions-from-dams-and-reservoirs/?gclid=CjwKCAjwhNWZBhB\\_EiwAPzlhNI0pfbS0X94haoRzPS8WxSBXRd6XunuAX3WVYpns6AC924gtux5eohoCUIMQAvD\\_BwE](https://www.americanrivers.org/2022/08/methane-admissions-from-dams-and-reservoirs/?gclid=CjwKCAjwhNWZBhB_EiwAPzlhNI0pfbS0X94haoRzPS8WxSBXRd6XunuAX3WVYpns6AC924gtux5eohoCUIMQAvD_BwE) (accessed: 29.09.2022).
- Cowan, M. A. (2022). *National Geographic - Plankton Revealed*. Available at: <https://education.nationalgeographic.org/resource/plankton-revealed> (accessed: 16.11.2022).
- Dam Removal Europe. (2019). *Tikkurila Dam, Vantaa, Finland*. Available at: <https://damremoval.eu/portfolio/tikkurila-dam-vantaa-finland/> (accessed: 11.09.2022).
- Dam Removal Europe. (2022a). *Dam Removal Award*. Available at: <https://damremoval.eu/dam-removal-award/> (accessed: 01.12.2022).
- Dam Removal Europe. (2022b). *River Tromsa, Norway*. Available at: <https://damremoval.eu/portfolio/river-tromsa/> (accessed: 15.08.2022).
- Ding, L., Liqiang, C., Ding, C. & Tao, J. (2018). Global Trends in Dam Removal and Related Research: A Systematic Review Based on Associated Datasets and Bibliometric Analysis. *Chinese Geographical Science*. doi: 10.1007/s11769-018-1009-8.
- Douglas, I., Anderson, P. M. L., Goode, D., Houck, M. C., Maddox, D., Nagendra, H. & Yok, T. P. (eds). (2021). *The Routledge Handbook of Urban Ecology*. 2nd ed. Abingdon, Oxon: Routledge.
- Drabløs, Ø., T. (2022, 28.01.2022). Oslo kommune ber innbyggere spare på vannet for å unngå vannmangel. *Aftenposten*. Available at: <https://www.aftenposten.no/oslo/i/Bjngj9/oslo-kommune-ber-innbyggerne-spare-paa-vannet-for-aa-unngaa-vannmangel>.
- Eldegard, K., Syvertsen, P. O., Bjørge, A., Kovacs, K., Støen, O. G. & van der Kooij, J. (2021). *Pattedyr: Vurdering av oter Lutra lutra for Norge. Rødliste for arter 2021*. Artsdatabanken. Available at: <https://artsdatabanken.no/lister/rodlisterforarter/2021/3729> (accessed: 02.12.2022).
- Eloranta, A., Thomassen, G., A., B. M., Andersen, O. & Gregersen, F. (2019). *Restoration potential of old dams in Norway*. NINA report 1628. Available at: <https://brage.nina.no/nina-xmlui/handle/11250/2587701> (accessed: 29.06.2022).
- Energifaktanorge. (2022). *Kraftproduksjon*. Available at: <https://energifaktanorge.no/norsk-energiforsyning/kraft-forsyningen/>.
- Engage Missoula. (2021). *Rattlesnake Dam Removal Project*. Available at: <https://www.engagemissoula.com/rattlesnake-reservoir-restoration>.
- FEMA. (2020). *Hazard Mitigation Assistance Division Year in Review*. FEMA report 2020. Available at: [https://www.fema.gov/sites/default/files/documents/fema\\_hma-2020-year-in-review-summary\\_031821.pdf](https://www.fema.gov/sites/default/files/documents/fema_hma-2020-year-in-review-summary_031821.pdf).
- Fergus, T., Hoseth, K. A. & Sæterbø, E. (2010). *Vassdragshåndboka, Håndbok i vassdragsteknikk*. Trondheim: Tapir Akademiske Forlag.
- Folkehelseloven. (2022). *Innledende bestemmelser nr.1 Formål*. Available at: <https://lovdata.no/dokument/NL/lov/2011-06-24-29> (accessed: 18.11.2022).
- Foss, A. S. (2015). *It takes decades to restore a river*. Available at: <https://sciencenorway.no/cultural-history-environmental-protection-forskningno/it-takes-decades-to-restore-a-river/1420666> (accessed: 11.11.2022).
- Fossen, H. (2018). *Geologi: Stein, mineraler, fossiler og olje*. Bergen: Fagbokforlaget.
- Fylkesmannen i Sør-Trøndelag. (2014). *Fagrunnlag for kroksjøer, flomdammer og meanderende elvepartier*. Available at: <https://www.statsforvalteren.no/siteassets/utgatt/fm-sor-trondelag/dokument-fmst/miljo-og-klima/vann/fagrunnlag-for-kroksjoer-flomdammer-og-meanderende-elvepartier.pdf> (accessed: 18.12.2022).
- Galen, D. & Newman, Z. Q. (eds). (2022). *Landscape Architecture for Sea Level Rise: Innovative Global Solutions*. New York: Routledge.
- GD. (2016, December 11.). Forbilledlig spleiselag. *Gudbrandsdølen Dagningen*. Available at: <https://www.gd.no/debatt/leder/flom/forbilledlig-spleiselag/o/5-18-385588> (accessed: 10.01.2023).
- González, E., Felipe-Lucia, M. R., Bourgeois, B., Boz, B., Nilsson, C., Palmer, G. & Sher, A. A. (2017). Integrative conservation of riparian zones. *Biological Conservation*, 211: 20-29. doi: <https://doi.org/10.1016/j.biocon.2016.10.035>.
- Green, G. (2022, May 16.). Record number of dams removed from Europe's rivers in 2021. *The Guardian*. Available at: <https://www.theguardian.com/environment/2022/may/16/record-number-of-dams-removed-from-europe-rivers-in-2021-aoe> (accessed: 01.12.2022).
- Habel, M., Mechkin, K., Podgorska, K., Saunes, M., Babiński, Z., Chalov, S., Absalon, D., Podgórski, Z. & Obolewski, K. (2020). Dam and reservoir removal projects: a mix of social-ecological trends and cost-cutting attitudes. *Scientific Reports*, 10 (1): 19210. doi: 10.1038/s41598-020-76158-3.
- Hanssen-Bauer, I., Førland, E. J., Haddeland, I., Hisdal, H., Mayer, S., Nesje, A., Nilsen, J. E. Ø., Sandven, S., Sandø, A. B., Sorteberg, A., et al. (2017). *Climate in Norway 2100 - a knowledge base for climate adaptation*. NCCS report 1/2017. Available at: <https://www.miljodirektoratet.no/publikasjoner/2017/mai-2017/climate-in-norway-2100--a-knowledge-base-for-climate-adaptation/> (accessed: 20.11.2022).
- Heggenes, J. & Sageie, J. (2006). *Rehabilitering av Måna, Tinn i Telemark: Tilstand og tiltak*. HiT skrift 6/2006. Available at: <https://openarchive.usn.no/usn-xmlui/handle/11250/2439159> (accessed: 29.10.2022).
- Heibl, R. (2022). *Måna 1998 - 2021*. Miljødirektoratet, Oslo: Økogrønt AS (Power point presentation 20.09.2022).
- Hind, L. J. (2020). *Våtmarkene - oaser for fugler og insekter*. Available at: <https://www.nibio.no/nyheter/vatmarkene--oaser-for-fugler-og-insekter> (accessed: 07.12.2022).



- Hovdhaugen, E. (1976). *Bygda vår: Ringeby historielag*. International Rivers, The Cyrus R. Vance Center for International Justice & Earth Law Center. (2020). *Rights of Rivers*. Available at: <https://www.internationalrivers.org/resources/reports-and-publications/rights-of-river-report/> (accessed: 15.11.2022).
- IPBES. (2018). *Summary of policymakers of the assessment report on land degradation and restoration of the Inter governmental Science-Policy Platform on Biodiversity and Ecosystem Services*. IPBES report.
- IPBES. (2019). *Global assessment report on biodiversity and ecosystem services of the Intergovernmental Science-Policy Platform on Biodiversity and Ecosystem Services*. In Brondizio, E., Diaz, S., Settele, J. & Nugo, H. T. (eds). Bonn, Germany.
- IPCC. (2022). *Climate Change 2022: Mitigation of Climate Change*. In Shukla, P. R., Skea, J., Resinger, A., Slade, R., Khoualdjia, A. A., Diemen, R. V., McCollum, D., Pathak, M., Some, S., Vyas, P., et al. (eds). Contribution of Working Group III to the Sixth Assessment Report of the Intergovernmental Panel on Climate Change. Cambridge, UK and New York, NY, USA.
- Johnsen, S. I., Museth, J. & Dokk, J. G. (2021). *Kartlegging av viktige funksjonsområder for fisk i Gudbrandsdalslågen*. NINA Rapport 1173. Available at: <https://brage.nina.no/nina-xmlui/handle/11250/2381859>.
- Jørgensen, D. (2017). Competing ideas of 'natural' in a dam removal controversy. *Water Alternatives*, 10: 840-852.
- Junge, C., Museth, J., Hindar, K., Kraabøl, M. & Vøllestad, L. A. (2014). Assessing the consequences of habitat fragmentation for two migratory salmonid fishes. *Aquatic Conservation: Marine and Freshwater Ecosystems*, 24 (3): 297-311. doi: <https://doi.org/10.1002/aqc.2391>.
- Kartverket. (2021). Ikke bare istiden som er årsak til landheving. Available at: <https://kartverket.no/om-kartverket/nyheter/til-lands/2021/mai/ikke-bare-istiden-som-erarsaktilandheving> (accessed: 08.12.2022).
- Keesstra, S., Nunes, J., Novara, A., Finger, D., Avelar, D., Kalantari, Z. & Cerdà, A. (2018). The superior effect of nature based solutions in land management for enhancing ecosystem services. *Science of The Total Environment*, 610-611: 997-1009. doi: <https://doi.org/10.1016/j.scitotenv.2017.08.077>.
- Klima- og miljødepartementet (ed.) (2015). *Vann, elver og våtmarker*: Merkur Grafisk AS.
- Kuenzer, C. & Renaud, F. G. (2012). Climate Change and Environmental Change in River Deltas Globally: Expected Impacts, Resilience, and Adaption. In, pp. 7-48. Dordrecht: Springer.
- Kuriqi, A., Pinheiro, A. N., Sordo-Ward, A., Bejarano, M. D. & Garrote, L. (2021). Ecological impacts of run-of-river hydropower plants—Current status and future prospects on the brink of energy transition. *Renewable and Sustainable Energy Reviews*, 142: 110833. doi: <https://doi.org/10.1016/j.rser.2021.110833>.
- Leyshon, C., Geoghegan, H. & Harvey-Scholes, C. (2019). Landscape and climate change. In Howar, P., Thompson, I., Waterton, E. & Atha, M. (eds) vol. 2nd *The Routledge Companion to Landscape Studies*, pp. 453-463. Oxon, Abingdon: Routledge.
- Limpert, K. E., Carnell, P. E., Trevathan-Tackett, S. M. & Macreadie, P. I. (2020). Reducing Emissions From Degraded Floodplain Wetlands. *Frontiers in Environmental Science*, 8. doi: 10.3389/fenvs.2020.00008.
- Miljødirektoratet. (2011). *Naturtyper: Flyaosa*. Available at: <https://faktaark.naturbase.no/?id=BN00108347> (accessed: 10.12.2022).
- Miljødirektoratet. (2012a). *Naturtyper: S for Fåvang 2*. Available at: <https://faktaark.naturbase.no/?id=BN00092488> (accessed: 10.12.2022).
- Miljødirektoratet. (2012b). *Naturtyper: S for Fåvang 1*. Available at: <https://faktaark.naturbase.no/?id=BN00092499> (accessed: 10.12.2022).
- Mooney, C. (2019, September 11.). Six takeaways from The Post's analysis of the globe's fastest-warming areas. *The Washington Post*. Available at: <https://www.washingtonpost.com/climate-environment/2019/09/11/six-takeaways-posts-analysis-globes-fastest-warming-areas/> (accessed: 28.11.2022).
- Mulligan, M., Soesbergen, A. V. & Sáenz, L. (2020). GOODD, a global dataset of more than 38,000 georeferenced dams. *Scientific Data* 7(31). doi: <https://doi.org/10.1038/s41597-020-0362-5>.
- Myrvold, K. M. (2022). *Verdens fiskevandringdag fremhever betydningen av økologisk konnektivitet*. Available at: <https://blogg.forskning.no/blogg-feriskvannsbloggen/verdens-fiskevandringdag-fremhever-betydning-av-okologisk-konnektivitet/2028046> (accessed: 25.08.2022).
- Nassauer, J. I. (1995). Messy Ecosystems, Orderly Frames. *Landscape Journal*, 14 (2): 161-170.
- Nienhuis, P. & Leuven, R. S. E. W. (2001). River restoration and flood protection: Controversy or synergism? *Hydrobiologia*, 444: 85-99. doi: 10.1023/A:1017509410951.
- Nilsson, C., Jansson, R., Kuglerová, L., Lind, L. & Ström, L. (2013). Boreal Riparian Vegetation Under Climate Change. *Ecosystems*, 16. doi: 10.1007/s10021-012-9622-3.
- Norderhaug, A. & Isdal, K. (1999). *Skjøtselsboka : for kulturlandskap og gamle norske kulturmarker*. Oslo: Landbruksforl.
- Nordrum, M. O. (1995). TROMSA - ein livsnerve frå gåmål. In *Hemgrenda 1995*, pp. 44-55: Ringeby Historielag.
- NOU 1991: 12B. 002/5 TROMSA. Available at: <https://webfileservice.nve.no/API/PublishedFiles/Download/201600028/1700316> (accessed: 03.10.2022).
- NVE. (2009). 00/5 Tromsa. Available at: <https://nevina.nve.no/> (accessed: 10.09.2022).
- NVE. (2013). *Tiltak i vassdrag: Uttak av grus i Tromsø*. NVE tiltaksplan, saksnummer: 201303648-55.
- NVE. (2019). *Tillatelse til permanent og midlertidig senkning av vannstand ved magasinet Trondalsdammene*: Norges vassdrag -og energidirektorat. Available at: <https://webfileservice.nve.no/API/PublishedFiles/Download/201833836/2652663> (accessed: 02.12.2022).
- NVE. (2021a). *Enkel klassifisering av dammer og trykkrør*. Available at: <https://www.nve.no/energi/tilsyn/damsikkerhet/enkel-klassifisering-av-dammer-og-trykkror/> (accessed: 06.10.2022).
- NVE. (2022a). NEVIDA Nedbørfelt-Vannføring-INdeks-Analyse. Available at: <https://nevina.nve.no/> (accessed: 20.10.2022).
- NVE. (2022b). *NVEs utvalgte kulturminner*. Available at: <https://www.nve.no/om-nve/nves-utvalgte-kulturminner/?Dammer> (accessed: 20.07.2022).
- NVEb. (2021). 002/5 Tromsa. Available at: <https://nevina.nve.no/> (accessed: 10.09.2022).
- Nykänen, M., Huusko, A. & Lahti, M. (2004). Changes in movement, range and habitat preferences of adult grayling from late summer to early winter. *Journal of Fish Biology*, 64 (5): 1386-1398. doi: <https://doi.org/10.1111/j.0022-1112.2004.00403.x>.
- Opperman, J. J., Galloway, G. E., Fargione, J., Mount, J. F., Richter, B. D. & Secchi, S. (2009). Sustainable floodplains through large-scale reconnection to rivers. *Science*, 326 (5959): 1487-1488. doi: 10.1126/science.1178256.
- Pethon, M., Kirkemo, O. & Vøllestad, A. (2022). *Ørret i Store norske leksikon på snl.no*. Available at: <https://snl.no/%C3%B8rret>.
- Pethon, P. (2021). *Aschehougs store fiskebok*. 2nd ed. Oslo: Aschehoug.
- Pilgrimsleden. (no date). *Gudbrandsdalsleden*: Oslo-Gjøvik/Hamar-Trondheim. Available at: <https://pilegrimsleden.no/en/trails/gudbrandsdalsleden> (accessed: 05.12.2022).
- Plan- og bygningsloven. (2021). *Kapittel 1. Fellesbestemmelser nr.1-8 (forbud mot tiltak mv. langs sjø og vassdrag)*. Available at: [https://lovdata.no/dokument/NL/lov/2008-06-27-71/KAPITTEL\\_1-1#KAPITTEL\\_1-1](https://lovdata.no/dokument/NL/lov/2008-06-27-71/KAPITTEL_1-1#KAPITTEL_1-1) (accessed: 11.10.2022).
- Poff, N. L. & Matthews, J. H. (2013). Environmental flows in the Anthropocene: past progress and future prospects. *Current Opinion in Environmental Sustainability*, 5 (6): 667-675. doi: <https://doi.org/10.1016/j.cosust.2013.11.006>.
- Prominski, M., Stokman, A., Stokman, A., Stimberg, D., Voermanek, H., Zeller, S. & Bajc, K. (2017). *River.Space.Design : Planning Strategies, Methods and Projects for Urban Rivers*. 2nd ed. Basel: Birkhäuser.
- Pulg, U., Barlaup, B., T, Skoglung, H., Velle, G., Gabrielsen, S., E, Stranzl, S., Espeland, E., O, Lehmann, G., B, Wiers, T., Skår, B., et al. (2017). *Tiltakshåndbok for bedre fysisk vannmiljø: God praksis ved miljøforbedrende tiltak i elver og bekker*. LFI rapport 296. Available at: <https://www.miljodirektoratet.no/globalassets/publikasjoner/m1051/m1051.pdf> (accessed: 10.09.2022).
- Rhoads, B. L. (2020). Chapter 1 - Introduction. In *River Dynamics: Geomorphology to Support Management*, pp. 1-14. Cambridge: Cambridge University Press.
- Rosset, V., Ruhi, A., Bogan, M. T. & Datry, T. (2017). Do lentic and lotic communities respond similarly to drying? *Ecosphere*, 8 (7): e01809. doi: <https://doi.org/10.1002/ecs2.1809>.
- Rowiński, P. M., Västilä, K., Aberle, J., Järvelä, J. & Kalinowska, M. B. (2018). How vegetation can aid in coping with river management challenges: A brief review. *Ecohydrology & Hydrobiology*, 18 (4): 345-354. doi: <https://doi.org/10.1016/j.ecohyd.2018.07.003>.
- Shao, X., Fang, Y., Jawitz, J., W, Yan, J. & Cui, B. (2019). River network connectivity and fish diversity. *Elsevier*, 689 (1 November): 21-30. doi: <https://doi.org/10.1016/j.scitotenv.2019.06.340>.
- Sneddon, C., Barraud, R. & Germaine, M. A. (2017). Dam removals and river restoration in international perspective. *Water Alternatives*, 10 (3): 648-654.
- Sørås, S., Jose, F., G. & Kraabøl, M. (2018). *Riving av Dam i Tromsaelva*. Multiconsult report 130957-RIVASS-RAP-001.
- SSB. (2021). 05277: *Folkemengde, etter alder, kjønn, statistikkvariabel, år og region*. Available at: <https://www.ssb.no/statbank/table/05277/tableViewLayout1/> (accessed: 29.11.2022).
- Staubo, I., Carm, K., Høegh, B. Å., L'Abée-Lund, J. H. & Å., S. S. (2019). *Kantvegetasjon langs vassdrag*. NVE Veileder 2/2019. Available at: [https://publikasjoner.nve.no/veileder/2019/veileder2019\\_02.pdf](https://publikasjoner.nve.no/veileder/2019/veileder2019_02.pdf).
- Stewart, D. B., Mochnacz, N., Reist, J., Carmichael, T. & Sawatzky, C. (2007). *Fish life history and habitat use in the Northwest Territories: Arctic grayling (Thymallus arcticus)*. Canadian Manuscript Report of Fisheries and Aquatic Sciences 2797. Available at: [https://www.researchgate.net/publication/255580930\\_Fish\\_life\\_history\\_and\\_habitat\\_use\\_in\\_the\\_Northwest\\_Territories\\_Arctic\\_grayling\\_Thymallus\\_arcticus](https://www.researchgate.net/publication/255580930_Fish_life_history_and_habitat_use_in_the_Northwest_Territories_Arctic_grayling_Thymallus_arcticus) (accessed: 17.11.2022).
- Szatten, D. & Habel, M. (2020). Effects of Land Cover Changes on Sediment and Nutrient Balance in the Catchment with Cascade-Dammed Waters. *Remote Sensing*, 12 (20). doi: 10.3390/rs12203414.



- Thompson, C. W. (2015). Chapter 13: Is landscape life? In Waldheim, C. (ed.) *Is Landscape...?: Essays on the Identity of Landscape*, pp. 302-326. London: Taylor and Francis.
- Thorsnæs, G. (2022). *Gudbrandsdalslågen*. Available at: <https://snl.no/Gudbrandsdalsl%C3%A5gen>.
- United Nations. (2022, December 19.). UN conference concludes with 'historic' deal to protect a third of the world's biodiversity. *UN News*. Available at: <https://news.un.org/en/story/2022/12/1131837> (accessed: 10.01.2023).
- United Nations. (no date-a). *Goal 3*. Available at: <https://sdgs.un.org/goals/goal3> (accessed: 11.12.2022).
- United Nations. (no date-b). *Goal 6*. Available at: <https://sdgs.un.org/goals/goal6> (accessed: 11.12.2022).
- United Nations. (no date-c). *Goal 13*. Available at: <https://sdgs.un.org/goals/goal13> (accessed: 11.12.2022).
- United Nations. (no date-d). *Goal 14*. Available at: <https://sdgs.un.org/goals/goal14> (accessed: 11.12.2022).
- United Nations. (no date-e). *Goal 15*. Available at: <https://sdgs.un.org/goals/goal15> (accessed: 11.12.2022).
- United Nations. (no date-f). Sustainable Development Goals, 17 Goals to Transform Our World. Available at: <https://www.un.org/sustainabledevelopment/> (accessed: 17.10.2022).
- Vannressursloven. (2001a). *Alminnelige regler om vassdrag nr. 11 (kantvegetasjon)*. Available at: [https://lovdata.no/dokument/NL/lov/2000-11-24-82#KAPITTEL\\_7](https://lovdata.no/dokument/NL/lov/2000-11-24-82#KAPITTEL_7).
- Vannressursloven. (2001b). *Nedlegging av vassdragsanlegg nr.41 (adgangen til å nedlegge vassdragsanlegg)*. Available at: [https://lovdata.no/dokument/NL/lov/2000-11-24-82#KAPITTEL\\_7](https://lovdata.no/dokument/NL/lov/2000-11-24-82#KAPITTEL_7) (accessed: 15.11.2022).
- Vassdragsreguleringsloven. (1917). *Nedleggelse av anlegg nr.10*. Available at: [https://lovdata.no/dokument/NL/lov/1917-12-14-17#KAPITTEL\\_4](https://lovdata.no/dokument/NL/lov/1917-12-14-17#KAPITTEL_4).
- Vereide, K., Mo, B., Forseth, T., Lia, L., Nysveen, A., Dahlhaug, O. G., Schäffer, L. E., Bustos, A. A., Sundt-Hansen, L., Øvregård, E., et al. (2020). *AlternaFuture - Final Report*. HydroCen Report nr.18.
- Vesikansa, K. (2022). An Oasis Along the Rapids. Available at: <https://www.ark.fi/en/2022/03/an-oasis-along-the-rapids/>.
- Veskje, K. (2013, July 2.). Mammut- eventyr i grustaket. *Gudbrandsdølen Dagningen*. Available at: <https://www.gd.no/nyheter/mammut-eventyr-i-grustaket/s/1-934610-6740068> (accessed: 21.08.2022).
- Warrick, J. A., Stevens, A. W., Miller, I. M., Harrison, S. R., Ritchie, A. C. & Gelfenbaum, G. (2019). World's largest dam removal reverses coastal erosion. *Scientific Reports*, 9 (1): 13968. doi: 10.1038/s41598-019-50387-7.
- Wohl, E. (2017). Connectivity in rivers. *Progress in Physical Geography: Earth and Environment*, 41 (3): 345-362. doi: 10.1177/0309133317714972.
- Xiang, H., Zhang, Y. & Richardson, J. (2016). Importance of Riparian Zone: Effects of Resource Availability at Land-water Interface. *Riparian Ecology and Conservation*, 3: 1-17. doi: 10.1515/remc-2016-0001.



## List of figures

**Figure 1a:** Fjeldberg, I. (2022). *Colorful slate at the dam site, river Tromsa*. Photography.  
**Figure 1b:** Fjeldberg, I. (2022). Remains of the dam in Tromsa river. Photography.

**Figure 2:** United Nations (no date). *UN Sustainable Development Goals*. Available at: <https://www.un.org/sustainabledevelopment/news/communications-material/>. (accessed 13.10.20223). Symbols.

**Figure 3a:** Fjeldberg, I. (2022). Based on figure by: Ritchie, H. (2019). *Global primary energy consumption by source*. Available at: <https://ourworldindata.org/energy-mix>. Creative Commons license (CC BY 4.0) <https://creativecommons.org/licenses/by/4.0/> (accessed 15.09.2022). Map.

**Figure 3b:** Fjeldberg, I. (2022). Based on map by Mulligan et al. (2020), Available at: <https://www.nature.com/articles/s41597-020-0362-5>. Creative Commons license (CC BY 4.0): <https://creativecommons.org/licenses/by/4.0/>. Map.

**Figure 3c:** Fjeldberg, I. (2022). Based on map by Mulligan et al. (2020), Available at: <https://www.nature.com/articles/s41597-020-0362-5>. Creative Commons license (CC BY 4.0): <https://creativecommons.org/licenses/by/4.0/>. Map.

**Figure 4:** Fjeldberg, I. (2022). *Under the water surface of river Tromsa*. Photography.

**Figure 5a:** Rhoads (2020) *Hierarchical morphological structure of alluvial river systems*. In *River Dynamics*, Introduction, p.11. Copyright: Cambridge University Press. PLSclear Ref No:73035, Reproduced with permission of Cambridge University Press through PLSclear. Diagram.

**Figure 5b:** Prominski et al. (2017) No title. In *River Space*. Design. p. 22. Open access. Diagram.

**Figure 5c:** Fjeldberg, I. (2022) *river movement*. Diagram.

**Figure 5d:** Sørås et al. (2018). In report: *Riving av Dam i Tromsaelva*, Appendix. Page 3. Table.

**Figure 6a:** Fjeldberg, I. (2022). *Alnus Incana along the riverside of Tromsa*. Photography.

**Figure 6b:** Fjeldberg, I. (2022). *Parts of the riparian vegetation along Tromsa river*. Photography.

**Figure 6c:** Fjeldberg, I. (2022). *Example of thriving riparian vegetation at Tromsa seen from the river*. Photography.

**Figure 6d:** Fjeldberg, I. (2022). *Explanation of vegetative zones at river sides*. Diagram.

**Figure 7:** Prominski et al. (2017). No title. In *River Space*. Design., p. 27. Diagram.

**Figure 8a:** Fjeldberg, I. (2022) Directly translation of table by NVE (2021), Available at: <https://www.nve.no/energi/tilsyn/damsikkerhet/enkel-klassifisering-av-dammer-og-trykkror/>. Table.

**Figure 8b:** AMBER (2022). *A representation of existing barriers in waterways in Europe*. Available at: <https://amber.international/european-barrier-atlas/>. Reproduced with permission.

**Figure 9a:** Fjeldberg, I. (2022). Diagram based on map data from the Global temperature report of 2021, by Berkeley Earth. Available at: <https://berkeleyearth.org/global-temperature-report-for-2021/>. Creative Commons license (CC BY-NC4.0): <https://creativecommons.org/licenses/by-nc/4.0/>. Map.

**Figure 9b:** Sparby, K. (1985). *Befaring m/bl. a. advokat Karlsrud til Tromsa, Ringebu. Flomsklader. Turbinrør. 1985*. Owner Norsk Skogbruksmuseum. Creative Commons License (CC BY-NC4.0): <https://creativecommons.org/licenses/by-nc/4.0/>. Photography.

**Figure 10:** Fjeldberg, I. (2022). *View from the Tromsa river*. Photography.

**Figure 11a:** Fjeldberg, I. (2022) *Share of primary energy from hydroelectric power, 2021*. Graphic remaid based on map by Our world in data. (2022). Available at: <https://ourworldindata.org/energy-mix>. Creative Commons License (CC BY 4.0) <https://creativecommons.org/licenses/by/4.0/>. Map.

**Figure 11b:** Nordregio (2008). *Generation of electricity in the Nordic countries*. Available at: <https://archive.nordregio.se/Maps/05-Environment-and-energy/Generation-of-electricity-in-the-Nordic-Countries/index.html>. (accessed 10.11.2022). Map.

**Figure 11c:** NVE (2022). *NVE vannkraft utbygd og ikke utbygd*. Layer: Dam\_N250. Available at: <https://temakart.nve.no/link/?link=vannkraft>. Accessed: 03.12.2022. Map.

**Figure 11d:** NVE (2022). *NVE vannkraft utbygd og ikke utbygd*, Layer: Vannkraftver. Available at: <https://temakart.nve.no/link/?link=vannkraft>. Accessed: 03.12.2022. Map.

**Figure 12a:** NCCS (2015). In M741, *Climate in Norway 2100*, p.20. Available at: <https://www.miljodirektoratet.no/globalassets/publikasjoner/M741/M741.pdf>. Map.

**Figure 12b:** NCCS (2015). In M741, *Climate in Norway*

2100, p.18. Available at: <https://www.miljodirektoratet.no/globalassets/publikasjoner/M741/M741.pdf>. Map.

**Figure 12c:** In M741, *Climate in Norway 2100*, p.31. Available at: <https://www.miljodirektoratet.no/globalassets/publikasjoner/M741/M741.pdf>. Map.

**Figure 13:** Piry Kantonen Photography. (2019). *Loki\_Tikurilla\_35*. Reproduced with permission provided by the photographer, Piry-Pekka Kantonen. Photography.

**Figure 14:** Fjeldberg, I. (2022). *In the Tromsa river*. Photography.

**Figure 15a:** Piry Kantonen Photography. (2019). *Vernissaouisto\_Aerial\_005*. Reproduced with permission provided by the photographer, Piry Kantonen. Photography.

**Figure 15b:** Piry Kantonen Photography. (2019). *Vernissapuisto\_Aerial\_009*. Reproduced with permission provided by the photographer, Piry-Pekka Kantonen. Photography.

**Figure 15c:** Loci Landscape Architects Finnlnd (no date). Available at: <https://www.ark.fi/en/2022/03/an-oasis-along-the-rapids/>

**Figure 15d:** Piry Kantonen Photography. (2019). *Tikkurila\_022*. Reproduced with permission provided by the photographer, Piry-Pekka Kantonen. Photography.

**Figure 15e:** Piry Kantonen Photography. (2019). *Kesä\_003*. Reproduced with permission provided by the photographer, Piry Kantonen Piry-Pekka Kantonen. Photography.

**Figure 15f:** Piry Kantonen Photography. (2019). *Tikkurila\_031*. Reproduced with permission provided by the photographer, Piry-Pekka Kantonen. Photography.

**Figure 15g:** Piry Kantonen Photography. (2019). *Kesä\_093*. Reproduced with permission provided by the photographer, Piry-Pekka Kantonen. Photography.

**Figure 16a:** City of Missoula (2019). *Draft Rattlesnake Greenbelt Existing condition*. Available at: <https://www.engagemissoula.com/rattlesnake-reservoir-restoration>. (accessed 14.10.2022). Reproduced with permission. Illustration.

**Figure 16b:** Eisenhand, T. (no date). *Blooming Clarikia from our seed mix*. Available at: <https://www.engagemissoula.com/rattlesnake-reservoir-restoration>. (accessed 14.10.2022). Reproduced with permission. Photography.

**Figure 16c:** City of Missoula (2018). *Aerial "before" photo - June 2018*. Available at: <https://www.engagemissoula.com/rattlesnake-reservoir-restoration/widgets/19912/photos/6241>. (accessed 14.10.2022). Reproduced with permission. Photography.

**Figure 16d:** City of Missoula (no date). *Creek Excavation Starting to Wrap up*. Available at: <https://www.engagemissoula.com/rattlesnake-reservoir-restoration/widgets/19912/photos/6664>. (accessed 14.10.2022). Reproduced with permission. Photography.

**Figure 16e:** City of Missoula (no date). *Former Dam Site Ready for Revegetation*. Available at: <https://www.engagemissoula.com/rattlesnake-reservoir-restoration/widgets/19912/photos/6664>. (accessed 14.10.2022). Reproduced with permission. Photography.

**Figure 17a:** Økogrønt AS (2022). *Rjukan sentrum 2003*. (Powerpoint presentation 20.09.2022 at Miljødirektoratet, Oslo). Presentation available at: <https://vannforeningen.no/foredrag/20-21-09-nasjonalt-seminar-om-restaurering-av-vassdrag-og-vatmarker/>. Reproduced with permission provided by Roland Heibl. Photography.

**Figure 17b:** Økogrønt AS (2022). *Rjukan sentrum etter tiltakene*. (Powerpoint presentation 20.09.2022 at Miljødirektoratet, Oslo). Presentation available at: <https://vannforeningen.no/foredrag/20-21-09-nasjonalt-seminar-om-restaurering-av-vassdrag-og-vatmarker/>. Reproduced with permission provided by Roland Heibl. Photography.

**Figure 17c:** Økogrønt AS (2022). *Måna 1998 - 2021*. (Powerpoint presentation 20.09.2022 at Miljødirektoratet, Oslo). Presentation available at: <https://vannforeningen.no/foredrag/20-21-09-nasjonalt-seminar-om-restaurering-av-vassdrag-og-vatmarker/>. Reproduced with permission provided by Roland Heibl. Photography.

**Figure 17d:** Økogrønt AS (2022). *Terskler*. (Powerpoint presentation 20.09.2022 at Miljødirektoratet, Oslo). Presentation available at: <https://vannforeningen.no/foredrag/20-21-09-nasjonalt-seminar-om-restaurering-av-vassdrag-og-vatmarker/>. Reproduced with permission provided by Roland Heibl. Illustration.

**Figure 17e:** Økogrønt AS (2022). *Kjøreterskel - nedre Måna1*. (Powerpoint presentation 20.09.2022 at Miljødirektoratet, Oslo). Presentation available at: <https://vannforeningen.no/foredrag/20-21-09-nasjonalt-seminar-om-restaurering-av-vassdrag-og-vatmarker/>. Reproduced with permission provided by Roland Heibl. Illustration.

**Figure 17f:** Økogrønt AS (2022). *Kjøreterskel - nedre Måna2*. (Powerpoint presentation 20.09.2022 at Miljødirektoratet, Oslo). Presentation available at: <https://vannforeningen.no/foredrag/20-21-09-nasjonalt-seminar-om-restaurering-av-vassdrag-og-vatmarker/>. Reproduced with permission provided by Roland Heibl. Photography.

**Figure 17g:** Økogrønt AS (2022). *Måna - gangsti*. (Powerpoint presentation 20.09.2022 at Miljødirektoratet, Oslo). Presentation available at: <https://vannforeningen.no/foredrag/20-21-09-nasjonalt-seminar-om-restaurering-av-vassdrag-og-vatmarker/>. Reproduced with permission provided by Roland Heibl. Photography.

**Figure 18:** Kantonen Photography. (2019). *Vernissapuisto\_042*. Reproduced with permission provided by the photographer, Piry Kantonen Photography. Photography.



**Figure 19a:** Fjeldberg, I. (2022) *Methology and process diagram*. Diagram.

**Figure 19b:** Fjeldberg, I. (2022). *the dam site, Tromsa, with vibrant colors*. Photography.

**Figure 20:** (map: Fjeldberg, I. (2022). *Location map and catchment area of Lågen and the river network*. Based on Topografisk Norgeskart WMS, Kartverket, (Accessed 12.12.2022) from: <https://register.geonorge.no/inspire-statusregister/topografisk-norgeskart/f004268c-d4a1-4801-91cb-daa46236fab7>. Catchment area calculated at NVE map service NEVINA (accessed 12.12.2022) from: <https://nevina.nve.no/>. Map of counties from: <https://commons.wikimedia.org/wiki/File:Fylkeskart-regionreform.jpg>. Map.

**Figure 21a:** Hafslund Eco Vannkraft (no date). *Harpefoss karafteverk flyfoto*. Reproduced with permission provided by the owner. Photography.

**Figure 21b:** Hafslund Eco Vannkraft (no date). *Hunderfossen dam flyfoto*. Reproduced with permission provided by the owner. Photography.

**Figure 21c:** Fjeldberg, I. (2022). *Lågen river with tributaries and dams*. Based on Topografisk Norgeskart WMS, Kartverket, (Accessed 20.09..2022) from: <https://register.geonorge.no/inspire-statusregister/topografisk-norgeskart/f004268c-d4a1-4801-91cb-daa46236fab7>. NVE Vannkraft utbygd og ikke utbygd (Accessed 20.09..2022) from: <https://temakart.nve.no/link/?link=vannkraft>. Map.

**Figure 21d:** Fjeldberg, I. (2022). *Thresholds constructed in the Tromsa river after the removal of the dam*. Photography.

**Figure 22a:** Fjeldberg, I (2022). *Location Fåvang*. Based on Map of counties from: <https://commons.wikimedia.org/wiki/File:Fylkeskart-regionreform.jpg>. Catchment area calculated at NVE map service NEVINA (accessed 09.11.2022) from: <https://nevina.nve.no/>. Map.

**Figure 22b:** Fjeldberg, I. (2022). *Catchment area of Tromsa, and nature conservation areas*. Based on Topografisk Norgeskart WMS, Kartverket, (Accessed 23.10.2022) from: <https://register.geonorge.no/inspire-statusregister/topografisk-norgeskart/f004268c-d4a1-4801-91cb-daa46236fab7>. Catchment area calculated at NVE map service NEVINA (accessed 09.11.2022) ) from: <https://nevina.nve.no/>. Naturvernrområder WMS, Miljødirektoratet, (accessed 09.11.2022) from: <https://register.geonorge.no/inspire-statusregister/vern-wms/fa6a495d-05a1-4c0d-ba67-45a1d47fca92>. Map.

**Figure 23:** Fjeldberg, I. (2022). *Landcover, Gudbrandsdalen*. Based on AR250 WMS, NIBIO, (accessed 10.11.2022) from: <https://www.nibio.no/tjenester/wms-tjenester/wms-tjeneste-ar250>. Catchment

area calculated at NVE map service NEVINA (accessed 09.11.2022). ) from: <https://nevina.nve.no/>. Map.

**Figure 24a:** Fjeldberg, I. (2022). *Soil, loose material map*. Based on Topografisk Norgeskart WMS, Kartverket, (Accessed 20.09..2022) from: <https://register.geonorge.no/inspire-statusregister/topografisk-norgeskart/f004268c-d4a1-4801-91cb-daa46236fab7>. Løsmasser WMS, NGU, (accessed 09.10.2022) from: <https://geo.ngu.no/mapservers/LosmasserWMS2>. Catchment area calculated at NVE map service NEVINA (accessed 09.11.2022). ) from: <https://nevina.nve.no/>. Map.

**Figure 24b:** Fjeldberg, I. (2022). *Geology at the dam site*. Photography.

**Figure 25a:** Veskje, K. (no date). *Fåvang sikres mot flom, samtidig som tungtrafikken til og fra industribedriftene ledes utenom sentrum*. Available at: <https://www.gd.no/debatt/leder/flom/forbilledlig-spleiselag/o/5-18-385588>. Reproduced with permission provided by the owner, Gudbrandsdølen Dagingen. Photography.

**Figure 25b:** Fjeldberg, I. (2022). *Caution zones for landslide and snow avalanches*. Based on Topografisk norgeskart 3 gråtone WMS, Kartverket (accessed 22.10.2022) from: <https://register.geonorge.no/varsler/topografisk-norgeskart-3-gratone/7f-c4f5b9-1964-4cd3-9f80-1e4fd8cb9f07>. Jord- og flomskred aktsomhetsområder WMS, Noreges vassdrags- og energidirektorat, (accessed 12.11.2022) from: <https://register.geonorge.no/inspire-statusregister/jord-og-flomskred-aktsomhetsomrader-wms/aac7c7d9-5101-49f2-870e-6e88c9633a38>. Snø og steinskred - Aktsomhetsområder WMS, Noreges vassdrags- og energidirektorat (accessed 12.11.2022) from: <https://register.geonorge.no/inspire-statusregister/sno-og-steinskred-aktsomhetsomrader-wms/1a-f1a34f-af1a-463e-a1bf-c3bcd1347c5e?InspireRegistry-Type=service>. Map.

**Figure 25c:** Fjeldberg, I. (2022). *200-year flooding scenario*. Based on Topografisk norgeskart 3 gråtone WMS, Kartverket (accessed 22.10.2022) from: <https://register.geonorge.no/varsler/topografisk-norgeskart-3-gratone/7fc4f5b9-1964-4cd3-9f80-1e4fd8cb9f07>. Flom aktsomhetsområder WMS, Noreges vassdrags- og energidirektorat (accessed 12.11.2022) from: <https://register.geonorge.no/inspire-statusregister/flom-aktsomhetsomrader-wms/834179b8-d189-4bc0-b00f-533ffe80faed>. Map.

**Figure 26a:** Ringeby kommune (2014). *Reguleringsplan for Tromsnesskogen*. Available at: <https://www.arealplaner.no/3439/arealplaner/162>. Map.

**Figure 26b:** Ringeby kommune (2015). *Fåvang*. Available at: <https://www.arealplaner.no/3439/arealplaner/164>. Map.

**Figure 27a:** Fjeldberg, I. (2022). *Cows of Fåvang*. Photography.

**Figure 27b:** Fjeldberg, I. (2022). *Ysterikroa with the high pipe*. Photography.

**Figure 27c:** Fjeldberg, I. (2022). *Town center of Fåvang*. Photography.

**Figure 28a:** Fjeldberg, I. (2022). *The landscape, at a site a few kilometers up the valley in Fåvang*. Photography.

**Figure 28b:** Fjeldberg, I. (2022). *Pedestrian track from The high bridge to the pilgrimage rest stop*. Photography.

**Figure 28c:** Fjeldberg, I. (2022). *Huset Granmo- restored house from the 1800s that until recently served as accommodation for travelers*. Photography.

**Figure 28d:** Fjeldberg, I. (2022). *View of Tromsa river towards Lågen from the bridge at Tromsnesvegen*. Photography.

**Figure 29a:** Fjeldberg, I. (2022). *View from the High Bridge down to Tromsa, and the quarry on the other side of Lågen*. Photography.

**Figure 29b:** Fjeldberg, I. (2022). *Resting stop for pilgrimages*. Photography.

**Figure 29c:** Fjeldberg, I. (2022). *Resting stop*. Photography.

**Figure 30:** Fjeldberg, I. (2022). *Analyse layers*. Based on Open street map XYZ tiles, retrieved (accessed 18.08.2022) from QGIS Software. Topografisk Norgeskart WMS, Kartverket, (Accessed 18.08..2022) from: <https://register.geonorge.no/inspire-statusregister/topografisk-norgeskart/f004268c-d4a1-4801-91cb-daa46236fab7>. AR5 WMS, NIBIO, (Accessed 18.08..2022) from: <https://www.nibio.no/tjenester/wms-tjenester/wms-tjenester-ar5>. Elevation curves, Ringeby municipality, provided by email 09.09.2022. Diagram.

**Figure 31a:** WiderøeAS (1952). *"Fåvang"*. Borrowed from Ringeby Historielag and reproduced with permission. Photography.

**Figure 31b:** Frich, J. (1840s). *Sketch of the High bridge*. In Bygda vår, p.51. Sketch.

**Figure 32:** Fjeldberg, I. (2022). *Timeline*. Diagram.

**Figure 33a:** Fjeldberg, I. (2022). *Important buildings and locations in the Tromsa area*. Based on Open street map XYZ tiles, retrieved (accessed 18.08.2022) from QGIS Software. Topografisk Norgeskart WMS, Kartverket, (Accessed 18.08..2022) from: <https://register.geonorge.no/inspire-statusregister/topografisk-norgeskart/f004268c-d4a1-4801-91cb-daa46236fab7>. Elevation curves, Ringeby municipality, provided by email 09.09.2022. Local history gathered from sources mentioned in the text and conversations with local people. Map.

**Figure 33b:** Fjeldberg, I. (2022). *Route to the Ice church map*. Based on Open street map XYZ tiles, retrieved (accessed 18.08.2022) from QGIS Software. Topografisk Norgeskart WMS, Kartverket, (Accessed 18.08..2022) from: <https://register.geonorge.no/inspire-statusregister/topografisk-norgeskart/f004268c-d4a1-4801-91cb-daa46236fab7>. Pilgrimage route rethrieved from: <https://pilegrimsleden.no/>. Map.

**Figure 34a:** Fjeldberg, I. (2022). Based on the open map source Kart.Finn.no, added historical map layers (accessed: 05.12.2022) from: <https://kart.finn.no/>. Diagram.

**Figure 34b:** Fjeldberg, I. (2022). Based on figure 34a. Diagram.

**Figure 34c:** Finn.no (2022). Open map source Kart.Finn.no layers (accessed: 05.12.2022) from: <https://kart.finn.no/>. Map.

**Figure 35:** Fjeldberg, I. (2022). *Remaining wetland areas*. Based on Open street map XYZ tiles, retrieved (accessed 18.08.2022) from QGIS Software. Topografisk Norgeskart WMS, Kartverket, (Accessed 18.08..2022) from: <https://register.geonorge.no/inspire-statusregister/topografisk-norgeskart/f004268c-d4a1-4801-91cb-daa46236fab7>. Naturtyper - DN-håndbok 13, Miljødirektoratet, (accessed 11.12.2022) from: [https://kartkatalog.miljodirektoratet.no/MapService/Details/naturtyper\\_hb13](https://kartkatalog.miljodirektoratet.no/MapService/Details/naturtyper_hb13). Map.

**Figure 36:** Fjeldberg, I. (2022). Annotated photo. Based on photography by Wideroe, 1952, borrowed from Ringeby Historielagistorielag and reproduced with permission. Photography.

**Figure 37a:** Fjedberg, I. (2022). *Map of tourist attractions*. Based on Topografisk norgeskart 3 gråtone WMS, Kartverket (accessed 22.10.2022) from: <https://register.geonorge.no/varsler/topografisk-norgeskart-3-gratone/7fc4f5b9-1964-4cd3-9f80-1e4fd8cb9f07>. Norge i bilder WMS-Ortofoto, kartveket (accessed 22.10.2022) from: <https://register.geonorge.no/inspire-statusregister/norge-i-bilder-wms-ortofoto/dcee8bf4-fdf3-4433-a91b-209c7d9b0b0f>. Map.

**Figure 37b:** Fjedberg, I. (2022). *Markings of the pilgrimage route*. Photography.

**Figure 38a:** Fjedberg, I. (2022). *Parts of the trail that lead to the Ice church*. Photography.

**Figure 38b:** Lie, H. (1902) *Iskirken innvendig, vinter, is, snø*. Reproduced with permission from the owner, Maihaugen. Photography.

**Figure 38c:** Lie, H. (1928). *Iskirken udvendig, vinter, is, snø*. Reproduced with permission from the owner, Ringeby historielag. Photography.



**Figure 39:** Artist not mentioned (1917). *Tromsa dam Fåvang Ringeby*. Reproduced with permission from the owner, Ringeby historielag. Photography.

**Figure 40a:** Multiconsult (2018). *Figur 1-3 (a)* Skisse av dam sett fra nedstrøms side, In report: Riving av Dam i Tromsaelva, p.7. Illustration.

**Figure 40b:** Berge, Ø. (no date). *Tromsa kraftverk Fåvang Ringeby*. Reproduced with permission from the owner, Ringeby historielag. Photography.

**Figure 40c:** Multiconsult (2018). *Figur 2-2 Lengdesnitt av dam med graveskråninger*, In In report: Riving av Dam i Tromsaelva, p.9. Illustration.

**Figure 40d:** Multiconsult (2018). *Tromsa\_plan og profil\_v3*. Illustration.

**Figure 41a:** *Fra Tromsa Elv ved Myre*. Reproduced with permission from the owner, Ringeby historielag. Photography.

**Figure 41b:** Fjeldberg, I. (2022). *Section A1-A2 - 1*. Illustration.

**Figure 42a:** Fjeldberg, I. (2022). *Section A1-A2 - 2*. Illustration.

**Figure 42b:** Fjeldberg, I. (2022). *Section A1-A2 - 3*. Illustration.

**Figure 42c:** Vigerudst, A. (no date). *Farlig gangbro over Tromsa ved Trones*. Owner: Norsk skogbruksmuseum. Creative commons licence (CC BY-ND 4.0): <https://creativecommons.org/licenses/by-nc/4.0/>. Photography.

**Figure 43a:** Solbakken, T. (2022). *At Dam Removal Europe*: <https://damremoval.eu/portfolio/river-tromsa/>. Reproduced with permission from Dam Removal Europe. Photography.

**Figure 43b:** Fjeldberg, I. (2022). *Situation in August 2022, after the spring flood had moved the rocks*. Photography.

**Figure 44a:** Fjeldberg, I. (2022). *Hydropower was produced in the basement of this building*. Photography.

**Figure 44b:** Fjeldberg, I. (2022). *Unit tag*. Photography.

**Figure 44c:** Fjeldberg, I. (2022). *Generator unit*. Photography.

**Figure 44d:** Fjeldberg, I. (2022). *Monitors*. Photography.

**Figure 44e:** Fjeldberg, I. (2022). *The hydropower station*. Photography.

**Figure 45a:** Fjeldberg, I. (2022). *Map indicating pilgrimage route*. Map.

**Figure 45b:** Ringlund, O. (2020). *IMG\_20201107\_134039*. Reproduced with permission from the photographer, Odleif Riglund. Photography.

**Figure 45c:** Ringlund, O. (2020). *IMG\_20201107\_134049*. Reproduced with permission from the photographer, Odleif Riglund. Photography.

**Figure 46a:** Fjeldberg, I. (2022). *A trail leading beside the dam and to the pilgrimage route and the High bridge*. Photography.

**Figure 46b:** Fjeldberg, I. (2022). *View into the open meadow*. Photography.

**Figure 46c:** Fjeldberg, I. (2022). *Old pipes*. Photography.

**Figure 47:** Fjeldberg, I. (2022). *Field map with annotations from visits*. Illustration.

**Figure 48a:** Fjeldberg, I. (2022). *Sound barriers from the infrastructure*. Based on Støy Veg WMS, Statens Vegvesen (accessed 20.12.2022) from: <https://kartkatalog.geonorge.no/metadata/stoey-veg-wms/4bbae38e-4718-481d-9827-237cd5e115c8>. Open street map XYZ tiles, retrieved (accessed 18.08.2022) from QGIS Software. Map.

**Figure 49a:** Fjeldberg, I. (2022). *Porous and Nutrient-rich geology*. Photography.

**Figure 49b:** Fjeldberg, I. (2022). *Variation in rock sizes in the river*. Photography.

**Figure 49c:** *Bedrock map*. Based on Berggrunn WMS3, Norges geologiske undersøkelse (accessed 10.12.2022) from: <https://kartkatalog.geonorge.no/metadata/51243d4e-e86e-474b-baf8-b7ccfb59fe8e>. Open street map XYZ tiles, retrieved (accessed 18.08.2022) from QGIS Software. Map.

**Figure 49d:** Fjeldberg, I. (2022). *View into the canyons from the High bridge*. Photography.

**Figure 50:** Fjeldberg, I. (2022). *The dam site seen in August*. Photography.

**Figure 51a:** Fjeldberg, I. (2022). *Athyrium filix-femina*. Photography.

**Figure 51b:** Fjeldberg, I. (2022). *The first stage of succession after the excavator removed the dam*. Photography.

**Figure 51c:** Fjeldberg, I. (2022). *Picea*. Photography.

**Figure 51d:** Fjeldberg, I. (2022). *Omphalodes verna*. Photography.

**Figure 51e:** Fjeldberg, I. (2022). *Alnus incana*. Photography.

**Figure 51f:** Fjeldberg, I. (2022). *Rubus idaeus*. Photography.

**Figure 51g:** Fjeldberg, I. (2022). *Vaccinium vitis-idaea*. Photography.

**Figure 51h:** Fjeldberg, I. (2022). *Tanacetum vulgare*. Photography.

**Figure 51i:** Fjeldberg, I. (2022). *Acer platanoides*. Photography.

**Figure 51j:** Fjeldberg, I. (2022). *Athyrium filix-femina*. Photography.

**Figure 51k:** Fjeldberg, I. (2022). *Chamaenerion augustifolium*. Photography.

**Figure 51l:** Fjeldberg, I. (2022). *Species registered between 2002 - 2022 at Artsdatabanken*. Based on Artskart (accessed 19.10.2022) from: [https://artskart.artsdatabanken.no/app/#m-ap/243772,6822964/14/background/greyMap/filter/%7B%22IncludeSubTaxonIds%22%3Atrue%2C%22Found%22%3A%5B2%5D%2C%22NotRecovered%22%3A%5B2%5D%2C%22BoundingBox%22%3A%22POLYGON%20\(\(242923.30672924887%206822430.925999635%2C244621.09579174887%206822430.925999635%2C244621.09579174887%206823497.99435901%2C242923.30672924887%206823497.99435901%2C242923.30672924887%206822430.925999635\)\)%22%2C%22Style%22%3A1%7D](https://artskart.artsdatabanken.no/app/#m-ap/243772,6822964/14/background/greyMap/filter/%7B%22IncludeSubTaxonIds%22%3Atrue%2C%22Found%22%3A%5B2%5D%2C%22NotRecovered%22%3A%5B2%5D%2C%22BoundingBox%22%3A%22POLYGON%20((242923.30672924887%206822430.925999635%2C244621.09579174887%206822430.925999635%2C244621.09579174887%206823497.99435901%2C242923.30672924887%206823497.99435901%2C242923.30672924887%206822430.925999635))%22%2C%22Style%22%3A1%7D). Norge i bilder WMS-Ortofot, kartveket (accessed 22.10.2022) from: <https://register.geonorge.no/inspire-statusregister/norge-i-bilder-wms-ortofoto/dcee8bf4-fdf3-4433-a91b-209c7d9b0b0f>. Map.

**Figure 52a:** Fjeldberg, I. (2022). *List of observed plants and mushrooms at Tromsa*. Table.

**Figure 52b:** Fjeldberg, I. (2022). *Trail toward the dam site*. Photography.

**Figure 53:** Fjeldberg, I. (2022). *Species at Tromsa*. Based on Kommunekart 3D, Norkart (accessed 02.11.2022) from: <https://3dx.kommunekart.com/?x=61.451791213076795&y=10.191508900907655&z=578.9950651705685&head=26.706223116565617&pitch=-28.7251888775256&roll=0.00012532558998399292>. Diagram.

**Figure 54:** Fjeldberg, I. (2022). *Sections for existing vegetation at Tromsa*. Illustrations.

**Figure 55a:** Fjeldberg, I. (2022). *Tromsa upstream of the dam, at the end of the Ice church trail*. Photography.

**Figure 55b:** Fjeldberg, I. (2022). *Squirrel in the forests of Fåvang*. Photography.

**Figure 56a:** Fjeldberg, I. (2022). *Habitat of trout and grayling*. Based on Topografisk Norgeskart WMS, Kartverket, (Accessed 18.08.2022) from: <https://register.geonorge.no/inspire-statusregister/topografisk-norgeskart/f004268c-d4a1-4801-91cb-daa46236fab7>. Figure 1, in Assessing the consequences of habitat fragmentation for two migratory salmonid fishes, Junge et al., 2013. Map.

**Figure 56b:** Fjeldberg, I. (2022). *One of the habitat pools at the dam site*. Photography.

**Figure 57a:** Olsen, P. H./NTNU (no date). *Ørret*. Available at: <https://snl.no/%C3%B8rret>. Creative commons license CC BY NC SA 3.0: <https://creativecommons.org/licenses/by-nc-sa/3.0/no/>. Photography.

**Figure 57b:** Fjeldberg, I. (2022). *Annual behavior, trout*. Diagram.

**Figure 57c:** Ristikent (no date). Available at: <https://ristikent.com/nb/fiske/harr>. Photography.

**Figure 57d:** Fjeldberg, I. (2022). *Annual behavior, grayling*. Diagram.

**Figure 58:** Fjeldberg, I. (2022). *Map of the existing situation*. Based on Open street map XYZ tiles, retrieved (accessed 18.08.2022) from QGIS Software. Norge i bilder WMS-Ortofot, kartveket (accessed 22.10.2022) from: <https://register.geonorge.no/inspire-statusregister/norge-i-bilder-wms-ortofoto/dcee8bf4-fdf3-4433-a91b-209c7d9b0b0f>. Elevation curves, Ringeby municipality, provided by email 09.09.2022. Map.

**Figure 59a:** Fjeldberg, I. (2022). *Section B1-B2*. Illustration.

**Figure 59b:** Fjeldberg, I. (2022). *The dam site*. Photography.

**Figure 59c:** Fjeldberg, I. (2022). *Playfulness at the river*. Photography.

**Figure 59d:** Fjeldberg, I. (2022). *Section C1-C2*. Illustration.

**Figure 59e:** Fjeldberg, I. (2022). *View of Tromsa, with the temporarily constructed road*. Photography.

**Figure 59f:** Fjeldberg, I. (2022). *View towards the High bridge*. Photography.

**Figure 59g:** Fjeldberg, I. (2022). *Top of the trail from the river side of Tromsa*. Photography.

**Figure 59h:** Fjeldberg, I. (2022). *The High bridge*. Photography.

**Figure 60a:** Fjeldberg, I. (2022). *Section D1-D2*. Illustration.

**Figure 60b:** Fjeldberg, I. (2022). *Extended pedestrian walkway along Tromsa*. Photography.

**Figure 60c:** Fjeldberg, I. (2022). *The playground*. Photography.

**Figure 61a:** Fjeldberg, I. (2022). *Section E1-E2*. Illustration.

**Figure 61b:** Google Streetview (2019). *View of bridge crossing Tromsa*. Available at: [https://www.google.com/maps/@61.4552237,10.190621,3a,75y,330.84h,90.68t/data=!3m7!1e1!3m5!1sqhav4DT7dfIM0Sa7m9WBn-Q!2e0!6shttps:%2F%2Fstreetviewpixels-pa.googleapis.com%2Fv1%2Fthumbnail%3Fpanoid%3Dqhav4DT7dfIM0Sa7m9WBnQ%26cb\\_client%3Dmaps\\_sv.tactile.gps%26w%3D203%26h%3D100%26yaw%3D62.624363%26pitch%3D0%26thumbfov%3D100!7i16384!8i8192](https://www.google.com/maps/@61.4552237,10.190621,3a,75y,330.84h,90.68t/data=!3m7!1e1!3m5!1sqhav4DT7dfIM0Sa7m9WBn-Q!2e0!6shttps:%2F%2Fstreetviewpixels-pa.googleapis.com%2Fv1%2Fthumbnail%3Fpanoid%3Dqhav4DT7dfIM0Sa7m9WBnQ%26cb_client%3Dmaps_sv.tactile.gps%26w%3D203%26h%3D100%26yaw%3D62.624363%26pitch%3D0%26thumbfov%3D100!7i16384!8i8192). Photography.

**Figure 61c:** Fjeldberg, I. (2022). *Nesseskogen park*. Photography.



**Figure 62a:** Fjeldberg, I. (2022). *Section F1-F2*. Illustration.

**Figure 62b:** Google Street View (2019). *View of Tromsa river*. Available at: [https://www.google.com/maps/@61.4531318,10.1850109,3a,75y,36.81h,91.66t/data=!3m7!1e1!3m5!1sMbYYVtPSlwt95rI0aNK-Rg!2e0!6shttps:%2F%2Fstreetviewpixels-pa.googleapis.com%2Fv1%2Fthumbnail%3Fpanoid%3DMbYYVtPSlwt95rI0aNK-Rg%26cb\\_client%3Dmaps\\_sv.tactile.gps%26w%3D203%26h%3D100%26yaw%3D98.83152%26pitch%3D0%26thumbfov%3D100!7i16384!8i8192](https://www.google.com/maps/@61.4531318,10.1850109,3a,75y,36.81h,91.66t/data=!3m7!1e1!3m5!1sMbYYVtPSlwt95rI0aNK-Rg!2e0!6shttps:%2F%2Fstreetviewpixels-pa.googleapis.com%2Fv1%2Fthumbnail%3Fpanoid%3DMbYYVtPSlwt95rI0aNK-Rg%26cb_client%3Dmaps_sv.tactile.gps%26w%3D203%26h%3D100%26yaw%3D98.83152%26pitch%3D0%26thumbfov%3D100!7i16384!8i8192). Photography.

**Figure 62c:** Fjeldberg, I. (2022). *Mammuten recreational area*. Photography.

**Figure 62d:** Fjeldberg, I. (2022). *Recreational trail alongside Tromsa*. Photography.

**Figure 62e:** Fjeldberg, I. (2022). *Stream from the swimming pond to Tromsa*. Photography.

**Figure 62f:** Fjeldberg, I. (2022). *Highway E6 at the outlet of Tromsa*. Photography.

**Figure 63a:** Fjeldberg, I. (2022). *Accessibility and restoration potential*. Based on Open street map XYZ tiles, retrieved (accessed 18.08.2022) from QGIS Software. Elevation curves, Ringebu municipality, provided by email 09.09.2022. Topografisk Norgeskart WMS, Kartverket, (Accessed 18.08..2022) from: <https://register.geonorge.no/inspire-statusregister/topografisk-norgeskart/f004268c-d4a1-4801-91cb-daa-46236fab7>. Diagram.

**Figure 63b:** Fjeldberg, I. (2022). *Threats summary maps*. Based on Open street map XYZ tiles, retrieved (accessed 18.08.2022) from QGIS Software. Topografisk Norgeskart WMS, Kartverket, (Accessed 18.08..2022) from: <https://register.geonorge.no/inspire-statusregister/topografisk-norgeskart/f004268c-d4a1-4801-91cb-daa46236fab7>. Flom aktsomhetsområder WMS, Noreges vassdrags- og energidirektorat (accessed 12.11.2022) from: <https://register.geonorge.no/inspire-statusregister/flom-aktsomhetsomrader-wms/834179b8-d189-4bc0-b00f-533ffe80faed>. Støy Veg WMS, Statens Vegvesen (accessed 20.12.2022) from: <https://kartkatalog.geonorge.no/metadata/stoey-veg-wms/4bbae38e-4718-481d-9827-237cd5e115c8>. Norge i bilder WMS-Ortofoto, kartverket (accessed 22.10.2022) from: <https://register.geonorge.no/inspire-statusregister/norge-i-bilder-wms-ortofoto/dcee8bf4-fdf3-4433-a91b-209c7d9b0b0f>. Diagram.

**Figure 63c:** Fjeldberg, I. (2022). *Effects of the dam removal in Tromsa*. Diagram.

**Figure 63d:** Fjeldberg, I. (2022). *Tromsa river*. Photography.

**Figure 64a:** Fjeldberg, I. (2022). *Strategy map*. Based on Open street map XYZ tiles, retrieved (accessed 18.08.2022) from QGIS Software. Elevation curves, Ringebu municipality, provided by email 09.09.2022.

Topografisk Norgeskart WMS, Kartverket, (Accessed 18.08..2022) from: <https://register.geonorge.no/inspire-statusregister/topografisk-norgeskart/f004268c-d4a1-4801-91cb-daa46236fab7>. Map.

**Figure 64b:** Fjeldberg, I. (2022). *Restabilization and prevent erosion*. Diagram.

**Figure 65a:** Fjeldberg, I. (2022). *Proposal*. Based on Open street map XYZ tiles, retrieved (accessed 18.08.2022) from QGIS Software. Elevation curves, Ringebu municipality, provided by email 09.09.2022. Topografisk Norgeskart WMS, Kartverket, (Accessed 18.08..2022) from: <https://register.geonorge.no/inspire-statusregister/topografisk-norgeskart/f004268c-d4a1-4801-91cb-daa46236fab7>. Map.

**Figure 65b:** Fjeldberg, I. (2022). *Illustrative section from the proposal*. Illustration.

**Figure 65c:** Fjeldberg, I. (2022). *Example of vegetation in meadows and wetlands*. Illustration.

**Figure 65c:** Fjeldberg, I. (2022). *Example of vegetation riparian vegetation*. Illustration.

**Figure 66:** Fjeldberg, I. (2022). *Perspective from the proposal*. Illustration.

**Figure 67a:** Fjeldberg, I. (2022). *View onto the river*. Illustration.

**Figure 67b:** Fjeldberg, I. (2022). *Elevated path in the meadow area*. Illustration.

**Figure 67c:** Fjeldberg, I. (2022). *Informal river crossings*. Illustration.

**Figure 67c:** Fjeldberg, I. (2022). *Wildlife observation points*. Illustration.

**Figure 68 :** Fjeldberg, I. (2022). *Connectivity*. Diagram.

**Figure 69a:** Fjeldberg, I. (2022). *Processes as a result of the proposal*. Illustration.

**Figure 69b:** Fjeldberg, I. (2022). *Processes as a result of the proposal in flooded periods*. Illustration.

**Figure 69b:** Fjeldberg, I. (2022). *Benefits for the trout and grayling*. Illustration.

**Figure 69d :** Fjeldberg, I. (2022). *Habitat pools*. Photography.

**Figure 70a:** Fjeldberg, I. (2022). *River movement*. Illustration.

**Figure 70b:** Fjeldberg, I. (2022). *Succession*. Illustration.





**Norges miljø- og biovitenskapelige universitet**  
Noregs miljø- og biovitenskapelige universitet  
Norwegian University of Life Sciences

Postboks 5003  
NO-1432 Ås  
Norway