

Norwegian University  
of Life Sciences

**Master's Thesis 2018 30 ECTS**

Faculty of Science and Technology  
Odd Ivar Lekang

# **Development of an inexpensive test-rig for particle sensors**

**Magnus Langeteig**

Machine, process and product development  
Faculty of Science and Technology



# DEVELOPMENT OF AN INEXPENSIVE TEST-RIG FOR PARTICLE SENSORS

*By*  
*Magnus Langeteig*



*Master's thesis – Machine, process and product development*

*Faculty of Science and Technology – NMBU*

*2018*



## PREFACE

---

This thesis is the concluding part of the master's degree in machine, process- and product development at the Norwegian university of life sciences. The assignment was carried out in the spring of 2018 as a project through Oak Lab, for the Khuri-Yakub research Group at Stanford University and ultimately Fluenta AS.

The motivation for this project and thesis, is a fascination for new technology, and how well-established technology can be used in a new way for new applications. The possibility to be a part of a research and development project trying to do exactly that, is really interesting. Using a well-established technology like ultrasound in a completely new way, trying to monitor microscopic particles in air is very fascinating. Investigating new and inexpensive ways to evaluate particle sensors has been challenging and rewarding.

I would like give thanks to my advisor, professor Odd Ivar Lekang for valuable guidance and support through the project. Further I would like to thank Kristian Omberg and Ola Omberg from the Oak Lab, for valued feedback and assistance. I would also like to thank the students Johan Stabekk and Harald Tryti Rieber, for helping assemble the test-rig. Finally, I would like to thank my fellow classmates for giving appreciated comments and feedback, as well as engaging in creative discussions.

*Aas 11<sup>th</sup> of May 2018*

---

*Magnus Langeteig*



## ABSTRACT

---

Air pollution is the leading environmental cause of death. Where almost all major cities in the world are breaking the pollution limits. Better tools to monitor and gather data, strengthening the decision-making basis for government agencies around the world is needed. The objective of this project is to create an inexpensive test-rig that can be used to test and evaluate particle sensors, contributing in the development of the CMUT sensor, developed at Stanford University.

Investigations into inexpensive possibilities surrounding particle dispersion, distribution and air flow has been done. Where large commercial companies mainly sell expensive instruments, where test-rigs studied had a price at over one million NOK. This thesis tries to find solutions producing similar results as the commercial solutions at a lower price. In order to get an understanding of particle properties, how they interact and behave, a theory review was produced. Further a technology and market assessment was conducted. This was done to get an understanding of the technology that already exists on the market. Further giving inspiration to the development process and reference points for the CMUT sensor.

A test-rig with three test setups has been made, where the main one is looped. Compatibility and interchangeability has been two key requirements in the development. Making the rig capable of adapting to different technologies and sensor systems on the market. The test-rigs two main components are the fan setup and the distribution solution. The fan setup was developed to control the flow in the test-rig. It consists of a pc fan and a fan plate specially designed to direct the air flow unidirectional. For control, an adjustable power supply is used, together with a relay setup, making it possible to pulsate the air flow. A distribution solution has been developed, where the goal was to uniformly distribute the particles into the sensor area, while at the same time having an even velocity. Further counteracting the rotational movement of the air, that the fan makes. Through flow simulation this was achieved.

To obtain an efficient dispersion of particles into the test-rig, inexpensive dispersions solutions were researched and presented, narrowing it down to a sandblaster and a paint gun. The two dispersion devices were tested using two different inexpensive laser scattering particle sensors. The results gave a clear indication that the sandblaster was most efficient, corroborating the research that was found. The price of the sandblaster and a commercial dispersion devices was compared, where the sandblaster came out 146 times cheaper than the commercial solution. Further testing is need to confirm the dispersion efficiency of the sandblaster.





## SAMMENDRAG

---

Luftforurensning er den miljøårsaken som har høyest dødelighet og nesten alle større byer i verden bryter forurensningsgrensene satt. Bedre verktøy for å overvåke og samle data, er nødvendig for å styrke beslutningsgrunnlaget for offentlige instanser over hele verden. Målet med dette prosjektet er å utvikle en rimelig testtrigg som kan brukes til å teste og evaluere partikkelsensorer, for å bidra i utviklingen av CMUT-sensoren utviklet på Stanford Universitet.

Undersøkelser rundt rimelige løsninger for partikkeldispersjon, distribusjon og luftstrøm ble gjort. Hvor store kommersielle selskaper selger dyre instrumenter, og testtrigget ble undersøkt og funnet med en pris på over en million NOK. Undersøker denne oppgaven løsninger som gir sammenlignbare resultater som en kommersielle løsningen til lavere pris. For å få forståelse og innsikt i partiklenes egenskaper, hvordan de samhandler med hverandre og hvordan de oppfører seg, ble en teoridel gjennomført. Videre ble teknologi- og markedsvurdering gjennomført. Dette ble gjort for å få en forståelse av teknologien som allerede eksisterer på markedet. Som videre gav inspirasjon til utviklingsprosessen og referansepunkter for CMUT-sensoren.

En testtrigg med tre testoppsett er laget, hvor hovedoppsettet er en sløyfe. Kompatibilitet og utskiftbarhet har vært sentrale krav i utviklingen. Noe som skal gjør riggen i stand til å tilpasse seg ulik teknologi og sensorsystemer på markedet. Testtriggens to hovedkomponenter er vifteoppsettet og distribusjonsløsningen. Vifteoppsettet er utviklet for å kontrollere testtriggens luftstrøm. Det består av en PC-vifte med en plate spesielt utformet for å få en ensrettet luftstrøm. For kontroll brukes en justerbar strømforsyning, sammen med et reléoppsett som gjør pulsering mulig. Distribusjonsløsningen er utviklet gjennom strømningsmodellering, hvor målet var å få jevn fordeling av partikler forbi sensorområdet, å samtidig ha jevn hastighet. Videre å motvirke den roterende bevegelsen på luften som viften lager. Dette ble oppnådd.

For å oppnå en effektiv dispersjon av partikler i testtriggen ble rimelige dispersjonsløsninger undersøkt, hvor en sandblåser og en malingspistol ble funnet. De to dispersjonsapparatene ble testet ved hjelp av to forskjellige rimelige partikkelsensorer som bruker laser spredning. Resultatene ga en tydelig indikasjon på at sandblåseren var mest effektiv, dette ble igjen styrket av studien som ble funnet. Prisen på sandblåseren og den kommersielle spredningsanordninger ble sammenlignet, hvor sandblåseren kom ut 146 ganger billigere enn den kommersielle løsningen. Ytterlig testing er nødvendig for å bekrefte dispersjonseffektiviteten til sandblåseren.



# TABLE OF CONTENTS

---

<b>PREFACE</b>	<b>I</b>
<b>ABSTRACT</b>	<b>III</b>
<b>SAMMENDRAG</b>	<b>V</b>
<b>1 INTRODUCTION</b>	<b>1</b>
1.1 AIMS OF THE STUDY	1
1.2 KHURI-YAKUB GROUP – STANFORD UNIVERSITY	3
1.3 DEVELOPMENT PROCESS	3
1.4 LITERATURE STUDY & RESEARCH METHODS	4
<b>2 BACKGROUND</b>	<b>5</b>
2.1 HEALTH PROBLEMS CAUSE BY PARTICLE POLLUTION	6
2.2 PARTICLE MATTER TYPES AND POLLUTION CAUSES	7
<b>3 THEORY AND TECHNOLOGY ASSESSMENT</b>	<b>9</b>
3.1 THE CMUT PARTICLE SENSOR	9
3.2 PARTICLE PROPERTIES	11
3.3 PARTICLE DISPERSION	15
3.4 MEASUREMENT TECHNIQUES FOR PM IN AIR	18
<b>4 COMMERCIALLY AVAILABLE SENSOR SYSTEMS</b>	<b>23</b>
4.1 INDUSTRIAL PARTICLE SENSOR SYSTEMS	23
4.2 PRIVATE INDOOR MARKET	27
4.3 SIMPLE AND INEXPENSIVE PARTICLE SENSORS	27
4.4 IN DEVELOPMENT	28
4.5 SENSOR SUMMARY	29
<b>DEVELOPMENT</b>	
<b>5 CONCEPTUALIZATION</b>	<b>31</b>
5.1 CURRENT TEST-RIG	31
5.2 TESTED SETUPS FROM OTHER STUDIES	32
5.3 TEST-RIG SPECIFICATIONS	33
5.4 CONCEPTUALIZATION OF TEST-RIG SETUPS	35
5.5 LAYOUT REVIEW	36
<b>6 COMPONENT REVIEW: HARDWARE &amp; SOFTWARE</b>	<b>39</b>
6.1 FAN SETUP	39
6.2 DISPERSION DEVICES	42

<b><u>7</u></b>	<b><u>PARTICLE REVIEW &amp; SELECTION</u></b>	<b><u>45</u></b>
7.1	UNIFORM PARTICLE SELECTION	45
7.2	POSSIBLE INEXPENSIVE PARTICLES	47
7.3	TECHNICAL SUMMARY	48
<b><u>8</u></b>	<b><u>FLOW SIMULATION: DESIGN &amp; DISTRIBUTION ANALYSIS</u></b>	<b><u>49</u></b>
8.1	PARTICLE DISTRIBUTION SOLUTION	50
8.2	FLOW DIRECTION ANALYSIS	57
8.3	SIMULATION SUMMARY	57
<b><u>9</u></b>	<b><u>FINAL ASSEMBLY OF TEST-RIG</u></b>	<b><u>59</u></b>
9.1	COMPLETE ASSEMBLY	59
9.2	REMAINING KEY COMPONENTS	60
9.3	PARTIAL ASSEMBLIES	63
9.4	COMPLETION- & REPETITIVE PROCEDURES	65
9.5	TEST-RIG	66
9.6	TOTAL TEST-RIG COST & DISPERSION COST COMPARISON	68
<b><u>10</u></b>	<b><u>TESTING OF TEST-RIG COMPONENTS</u></b>	<b><u>69</u></b>
10.1	FAN TESTING	69
10.2	DISPERSION DEVICE TESTING	71
10.3	CIRCULATION TESTING FULL RIG	79
10.4	TESTING SUMMARY	80
<b><u>11</u></b>	<b><u>DISCUSSION &amp; PROCESS EVALUATION</u></b>	<b><u>81</u></b>
11.1	DISCUSSION OF RESULTS	81
11.2	PROCESS DISCUSSION	82
<b><u>12</u></b>	<b><u>CONCLUSION</u></b>	<b><u>85</u></b>
12.1	COMPLETION OF OBJECTIVES	85
12.2	DEVELOPMENT RESULTS	85
12.3	RECOMMENDATIONS & FUTURE WORK	86
<b><u>13</u></b>	<b><u>REFERENCES</u></b>	<b><u>89</u></b>
<b><u>14</u></b>	<b><u>APPENDICES</u></b>	<b><u>95</u></b>

# ACRONYMS AND GLOSSARY

---

## ACRONYMS

CFD – Computational fluid dynamics

PM – Particle matter

PM10 – Particle matter under 10 micron and over 2,5 micron

PM2.5 – Particle matter under 2.5 micron

PM0.1 – Particles under 0.1 micron

R&D – Research and development

## GLOSSARY

Oak Lab – Eik Ideverksted

Particle(s) – Always references to particles like dust or smoke, not electrons, protons, etc.

Stanford group - Khuri-Yakub Group, Stanford University



# 1 INTRODUCTION

---

*This chapter gives an introduction to the thesis and the project. The research group developing the sensor is presented, the aim of the study is put forth, with an explanation of the objective and the limitations. The reader also gets information surrounding the methods, structure and terminology used in the report.*

## 1.1 AIMS OF THE STUDY

In a world where more and more people move into the city, there is a rising problem with hazardous particle accumulation in urban areas. Even in a highly developed country like Norway, the recommended air quality criteria's set by the Norwegian institute of public health and Norwegian environment agency are often not upheld. This is the same or worse for most of the large cities around the world making a large part of the world's population exposed to hazardous gases and particles [1].

The world we live in is surrounded by sensors, they are small, low-cost and available for several different measurable factors. In a smartphone there are several sensors, they can see with a camera, hear with a microphone, feel touch with the screen and movement with the help of a gyroscope, but they cannot smell. The sensor technology for a high performance chemical or aerosol sensors have not come as far, as they are very expensive. This despite it being one of the biggest environmental problems facing the planet today [2].

The Khuri-Yakub research group at Stanford have and are carrying out a long going extensive research and development study. On the possibility of using a capacitive micro-machined ultrasonic transducer (CMUT) for aerosol detecting and classification, with a focus on particle matter below 2.5 micron. This thesis aims to assist in the development of the CMUT sensor, by making a sensor test-rig that can be used for testing and evaluation of the CMUT sensor.

### OBJECTIVE

*Overall goal: This thesis aims to make an inexpensive test-rig for particle sensor testing. The rig shall be able to create a uniformly distributed and suspended particle flow, and suitable particles with a uniform size shall be identified, and be used for testing.*

To get a better overview of this overall goal, several intermediate goals is set up in a list underneath:

1. Give an introduction to particulate matter and the problems that comes with it.
2. Present the technology surrounding the CMUT sensor being developed by the Khuri-Yakub research group at Stanford.
3. Provide a theory section, setting the foundation for the thesis.
4. Give an overview of relevant measurement techniques for PM measurement in air.
5. Review the commercial sensor market today and products in development, to get a grasp of how far the technology has come and what sort of limitations there are.
6. **Development and preliminary testing of test-rig.**
  - a. Produce a uniform distribution of particles.
  - b. Research relevant components to control the flow in the test-rig.
  - c. Classify and test possible devices for dispersion of bulk powder particles.
  - d. Identify suitable particle matter for testing.
  - e. Construct a thorough flow simulation analysis to measure the flow in the test-rig, in order to make calculated decisions on parts and solutions.
  - f. Measure particle dispersion using inexpensive particle sensors.
  - g. Select final parts and solutions.
  - h. Evaluate the sustainability of the model.
7. **Evaluate the results**, discuss the suggested solutions and results, and propose future work and research needed.

#### LIMITATIONS & RESTRICTIONS

- **Budget:** The budget will limit the possibilities to buy certain product and devices. This makes it an objective to work around this problem coming up with inexpensive solution within the budget parameters.
- **Parts & material selection:** If possible, parts and materials will be taken from the workshop at the faculty and/or the makerspace Oak Lab. Therefore chosen because of availability and that they fulfil the requirements set.
- Only **CFD** will be performed. The thesis will not include mathematical modelling.
- Only **dry dispersion** (Not wet) of particles will be looked at. Dry methods are easier to develop and maintain, making it favourable when low-cost is a factor.
- The test system will be developed using **low-cost particle sensors** to test the size distribution and dispersion efficiency of the solutions, as the CMUT is currently being developed at Stanford. Meaning this system will be made for future testing of the CMUT prototype and possibly other particle sensors.



- Testing of the **complete test-rig** will not be performed. The analysis of testing the test-rig with the CMUT sensor or others, includes using expensive equipment not within the budget of this thesis. Therefore, only selection and testing of the components/solutions will be done. As well as building the test-rig assembly, making it ready for use.

## 1.2 KHURI-YAKUB GROUP – STANFORD UNIVERSITY

It is a research group at Stanford university which is led by professor in electrical engineering, Butrus Khuri-Yakub. The Khuri-Yakub groups field of research is on CMUT technology and how it can be used as a sensor for various applications, beyond what is already utilized. The goal is to develop a complete sensor system with CMUT technology that has a noticeable lower price than equivalent systems on the market. This thesis tries to contribute to the work done developing this sensor system. The group works in collaboration with Fluenta AS, which is a sensor development company, that is a leader within the use of ultrasonic sensing to detect flare gas, with a market cap of more than 75% of the offshore market [3].

## 1.3 DEVELOPMENT PROCESS

An overview of how the development process will be conducted in rough terms (Figure 1-1).

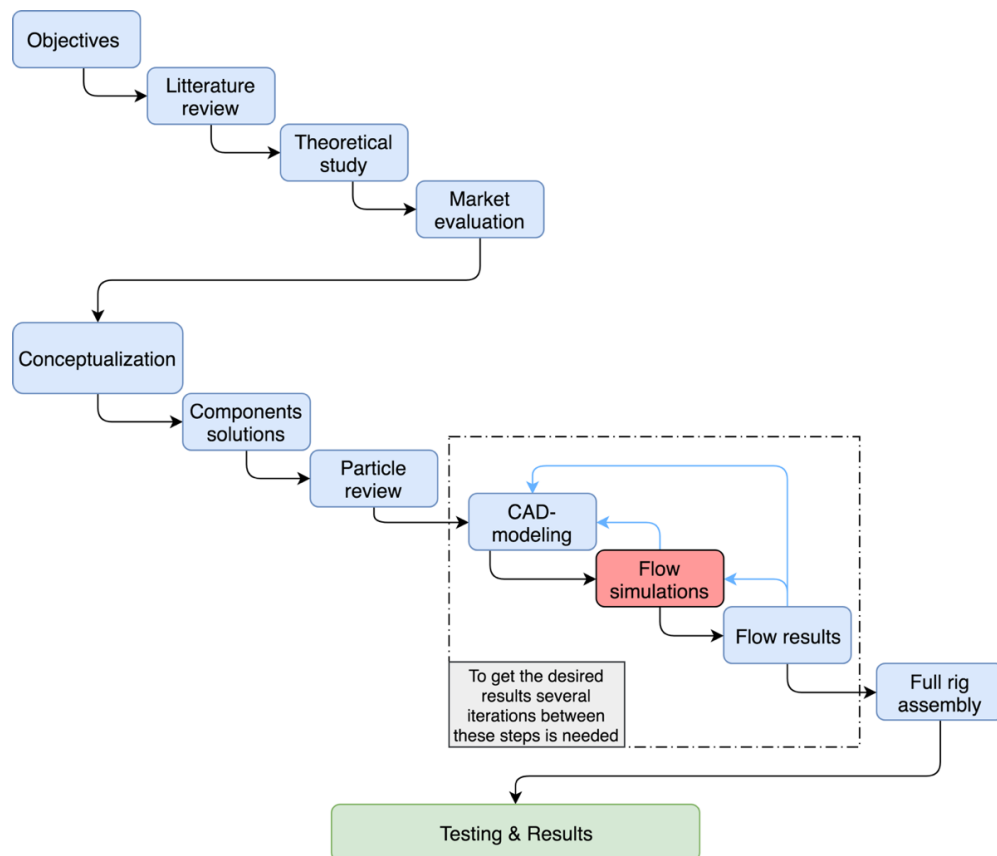

Figure 1-1: Illustration of the main development process steps, step for step.

## **1.4 LITERATURE STUDY & RESEARCH METHODS**

This master is a research and development study and therefore has its information foothold in researching relevant topic and review earlier studies. Giving inspiration and factual content to the development process. Examining earlier studies that is significant to the field of study is standard practise during a R&D project. This is done to put the work of the project into a discipline of a larger magnitude. The most relevant reports and studies for this thesis has been found through researching scientific databases for theory and information. See appendix J for quality assurance.

The thesis contains several tests and experiments were large datasets are used to present results. Statistical analysis, comparisons between different results, etc. have been conducted. Programs have been used to make informative illustrations and presented solutions in a more visual way. Through the development process different methods has been used both for development and production, as well as materials. This can be found in appendix K. How the different experiments have been performed is explained through the development. The results and finding that has arrived at and found through this project is both of a theoretical, analytical and hands-on experimental nature. Formulas and symbols used through the thesis is explained where they are used.

## 2 BACKGROUND

*This chapter gives a background into the importance and reason for this project. Presenting the problems surrounding particle pollution, health problems and guidelines set by environmental institutions. Showing the magnitude of the problem.*

Air pollution is according to the World health organization (WHO), the biggest single environmental health risk that we are facing in today's society [2]. Studies conducted from around the world conclude that exposure to air pollution is connected to cardiovascular and respiratory health issues, that may lead to hospital admission or even death [2]. WHO stated in may 2018:

*“9 out of 10 people breathe air containing high levels of pollutants. Updated estimations reveal an alarming death toll of 7 million people every year caused by ambient (outdoor) and household air pollution.” [4]*



*Figure 2-1: Pictures showing the air and particle pollution in respectively Beijing and Los Angeles. [87] [88]*

Beijing and other major cities around the world regularly choke in extremely high particle pollution (Figure 2-1). For low- and middle income cities with a population over 100.000, 98% does not meet the international standards set by WHO, for high income cities it goes down to 56% [5]. But even for a developed city like London it only took a week into 2016 to breach its annual pollution limits, and in 2018 it took them a month [6] [7].

These studies and estimates tell a story of how the world need to change to meet the requirements set by WHO and other health organizations. To do this, air pollutions levels should to be monitored closely to understand the problem, and from there make changes in order to solve it. To effectively do this a higher level of data gathering is needed to get a better picture of the current situation. This demands a high quantity of sensors in which need to be relatively low-cost in order to be feasible to implement. Currently, most major cities around the world

only have a few sensors to monitor these emissions; this is not enough to be able to track the different levels of pollution. The good news is that installation of monitoring equipment is increasing [4]. Cities are complex and elaborate environments with vast and immense emission sources. Being able to have a low-cost particle sensor system in a coordinated grid in the world's biggest cities and especially in the developing world, could give new insight into how to battle this pressing environmental issue.

## 2.1 HEALTH PROBLEMS CAUSE BY PARTICLE POLLUTION

Epidemiological studies have shown that both short and long term exposure to air/particle pollution can have a significant impact on the general health. By reducing the level of air pollution, the burden of disease can be reduced from stroke, heart disease, lung cancer, and both chronic and acute respiratory diseases, including asthma. [2]

Groups that are especially prone to particle pollution is elders, sick and children. Particle matter can irritate and cause inflammation of the lungs, increased cough, bronchitis and aggravated asthma. High concentration of particle matter over a longer time is responsible for over half a million people dying to early only in Europe, of respiratory diseases, cardiovascular disease or lung cancer. These numbers are even worst for developing countries, where people are exposed to both higher indoor and outdoor pollution than the in the western world (Figure 2-2). It is estimated that 3 million premature deaths occurred in 2018, where 88% was in low to middle income countries (developing countries). [8]

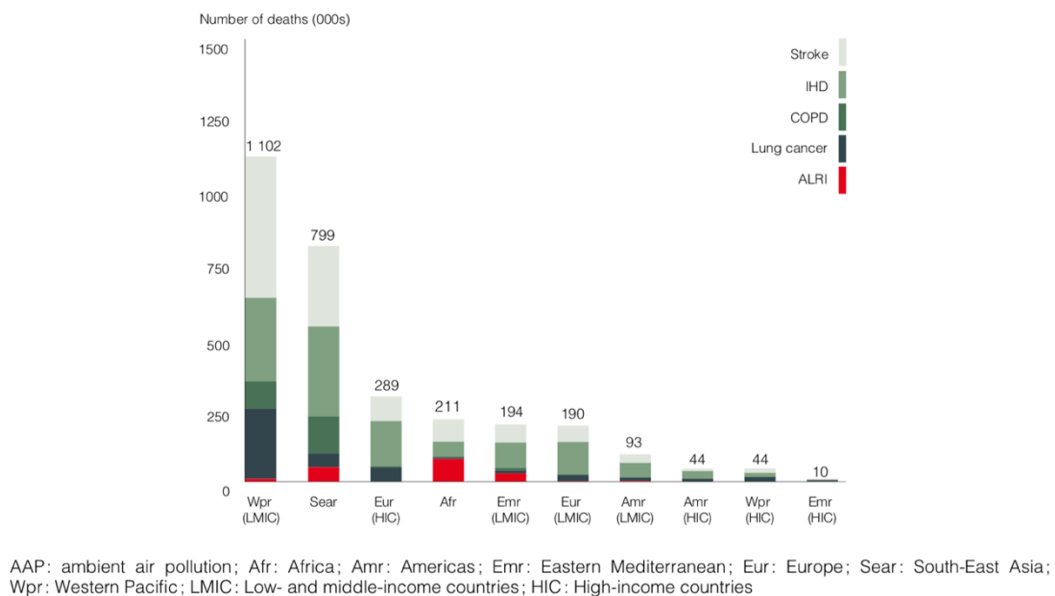

Figure 2-2: Deaths attributable to AAP (Ambient air pollution) in 2012, by disease and region. [2]

## 2.2 PARTICLE MATTER TYPES AND POLLUTION CAUSES

Particle matter or PM, also called particle pollution is the term used to describe suspended substances in the air. Of all pollutants, PM affects the most people. Main components found in PM is sulphate, nitrates, ammonia, sodium chloride, black carbon, mineral dust and water [8]. Particle pollution can vary in both size and complexity. Particle matter size can be put in to three main categories:

**PM<sub>10</sub>:** Particles between 2,5-10  $\mu\text{m}$  in diameter are called coarse particles. These particles are largely formed due to wear on car parts and road surfaces. Particles from brakes and tires contain a lot of metals like lead, copper, cadmium and zinc, while inorganic particles from the road surface are rich in minerals such as silicon, aluminium, calcium and sodium. Some organic matter such as pollen, fungus spores and residues/waste from plants and animals may also occur in this coarse fraction [9]. They will normally remain suspended for a couple of minutes to a few hours and fall to the ground within a few kilometres from the source. [1]

**PM<sub>2,5</sub>:** Particles up to 2,5 $\mu\text{m}$  in diameter are called fine particles. Fine combustion particles consist largely of condensed hydrocarbons and sulphates, as well as soot particles with a carbon core and traces of metallic ash covered by condensed organic compounds and sulphate. The organic compounds include polycyclic aromatic hydrocarbons [10]. They can remain suspended for days to weeks and has a radius from the source up to thousands of kilometres [1].

**PM<sub>0,1</sub>** Particles under 0,1 $\mu\text{m}$  in diameter are called ultra-fine particles. Combustion engines and  $\text{NO}_x$  are common emitters of ultra-fine particle [1], 3D-printing machines are also a source for ultra-fine particles [11]. PM<sub>0,1</sub> has an insufficient data basis compared to PM<sub>10</sub> and PM<sub>2,5</sub>.

The world health organization's guidelines values for particle pollution can be seen below:

**WHO Guideline values** [12]:

PM<sub>10</sub>: annual mean: 20  $\mu\text{g}/\text{m}^3$ , 24-hour mean: 50  $\mu\text{g}/\text{m}^3$

PM<sub>2.5</sub>: annual mean: 10  $\mu\text{g}/\text{m}^3$ , 24-hour mean: 25  $\mu\text{g}/\text{m}^3$

The Norwegian institute of public health (NIPH) is responsible for the air quality regulation for Norway. Their main goal with these regulation is to prevent health problems connected with air pollution. To do so the criteria's put forth are set so low that anyone can be exposed to these levels without taking any harm from it. Their own guidelines are presented below.

**NIPH Guideline values [1]:**

PM10: annual mean: 20  $\mu\text{g}/\text{m}^3$ , 24-hour mean: 30  $\mu\text{g}/\text{m}^3$

PM2.5: annual mean: 8  $\mu\text{g}/\text{m}^3$ , 24-hour mean: 15  $\mu\text{g}/\text{m}^3$

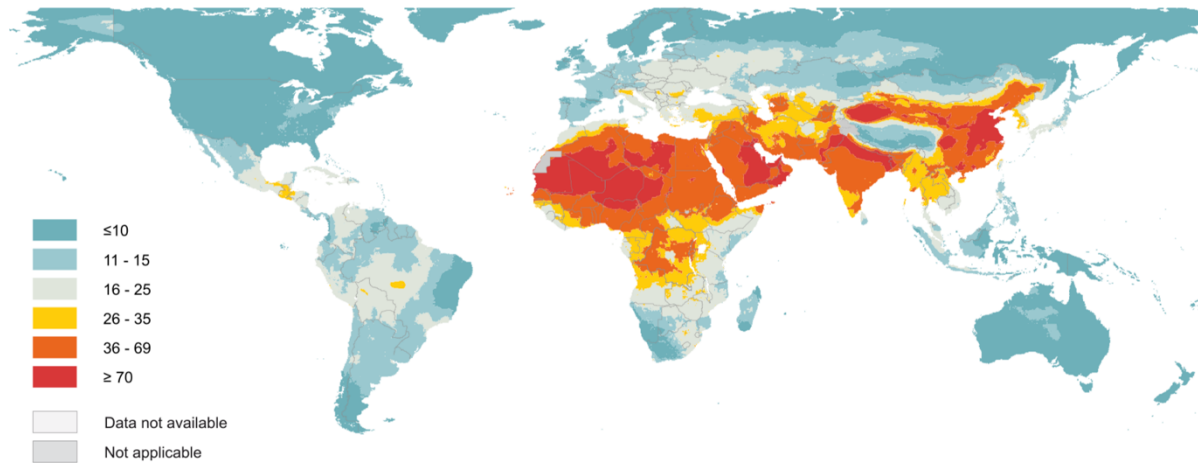

PM<sub>2.5</sub> : Fine particulate matter of 2.5 microns or less.

*Figure 2-3: Global map of modelled annual median concentration of PM2.5, in  $\mu\text{m}/\text{m}^3$  [2]*

From Figure 2-3, it can be seen that it is the developing world that is facing the biggest challenges. Where it as Africa and Asia that has the highest pollution levels, with extremely high PM2.5 levels.

### 2.2.1 CAUSES OF PARTICLE POLLUTION

When it comes to sources of PM it can be divided into two groups, stationary and mobile sources. Stationary sources are heavy industry, combustion plants, construction sites etc. In cities in developing countries, wood-burning ovens can be a large contributor, this is also the case for Norwegian cities in the winter months. The mobile sources are the main contributor to PM, which is cars, motorcycles and most important heavy goods vehicle traffic. According to the US Environmental Protection Agency (EPA) diesel exhaust contains 20.000 chemical compounds. Therefore, a big share of the pollution come from diesel cars without particle filters. [1]

### **3 THEORY AND TECHNOLOGY ASSESSMENT**

---

*This chapter is meant to give the reader a foundation of relevant theory and technology, giving the reader a understanding of the important topics surrounding this thesis. It gives an overview of relevant theory of the CMUT sensor and particle properties. Further presenting different PM measurement techniques.*

#### **3.1 THE CMUT PARTICLE SENSOR**

The CMUT particle sensor is a R&D project conducted by the Khuri-Yakub research group at Stanford. As hazardous concentrations of particles is a bigger and bigger issue, the need to monitor them is increasing. The research group aims to make an aerosol sensor using capacitive micro-machined ultrasonic transducer (CMUT) technology, which is inexpensive, accurate and reliable. Reducing the cost of high performance particle sensors could make it possible for people to monitor the particle concentration and type in the surrounding air. To get a better understanding of how the CMUT sensor works and how it is built, the next sub-chapters will give a theoretical understanding.

##### **3.1.1 CMUT THEORY**

###### **ULTRASONIC WAVES**

The definition of ultrasound is sonic waves over a frequency of 15 kHz. The change in acoustic impedance in different materials is the basis for ultrasonic imaging. When transmitting an ultrasonic signal, the waves will hit possible obstacle and partially transmit and reflect, depending on the material. From the time of flight variations, the deep can be calculated. [13]

Ultrasonic waves are only longitudinal in gas and fluid, but both longitudinal and transversal in solids. For longitudinal waves the particle direction is the same as the propagating wave direction, as for transversal they move perpendicular to the direction of the wave. A rigid material is needed for a transversal wave to move, as one particle moves it needs to be able to pull on the neighbouring particle and not slide past it like in a non-rigid medium (gas/liquid). However transducer design meant for gas/liquid need to take the transversal wave into account, as the transducer material is rigid. A transducer is a device that can transform an energy form from one type to another. An ultrasonic transducer transforms electrical energy into mechanical waves. [13]

### CAPACITIVE MICRO-MACHINED ULTRASONIC TRANSDUCERS (CMUT)

Capacitive transducers have existed for a long time and is used to transmit and/or receive ultrasound. It has been used to measuring distance in robotics, non-destructive evaluation and for measuring sound. It was first made in 1917 for sound measurement. It was a simple design mainly consisting of a diaphragm constructed of a thin plate of steel mounted in an air-filled gap, and a metal plate on one side. As a sound wave hit the diaphragm it vibrated, by measuring the change in capacitance between the diaphragm and the plate the soundwave could be calculated. [13]

Piezoelectric micro-machined ultrasonic transducers have for a long time been the main technology used in the ultrasonic transducer market. But it has its limitations. Piezoelectric transducer is not effective in air because of their high acoustic impedance. Capacitive transducers can provide a better match for both air and fluid as it has a low acoustic impedance and can therefore provide a better acoustic balance [14]. Further it has in recent years emerged as a possible better and more viable option as it can offer a wider range of bandwidth, easier production of large arrays and a potential to be integrated with supporting circuits.

Capacitive micro-machined ultrasonic transducers (CMUT) is a silicon base assembly which can be used to both generate and receive ultrasonic signals. The CMUT can be applied to a wide range of market segments, such as medical imaging, chemical sensors, non-destructive maintenance and more. [15]

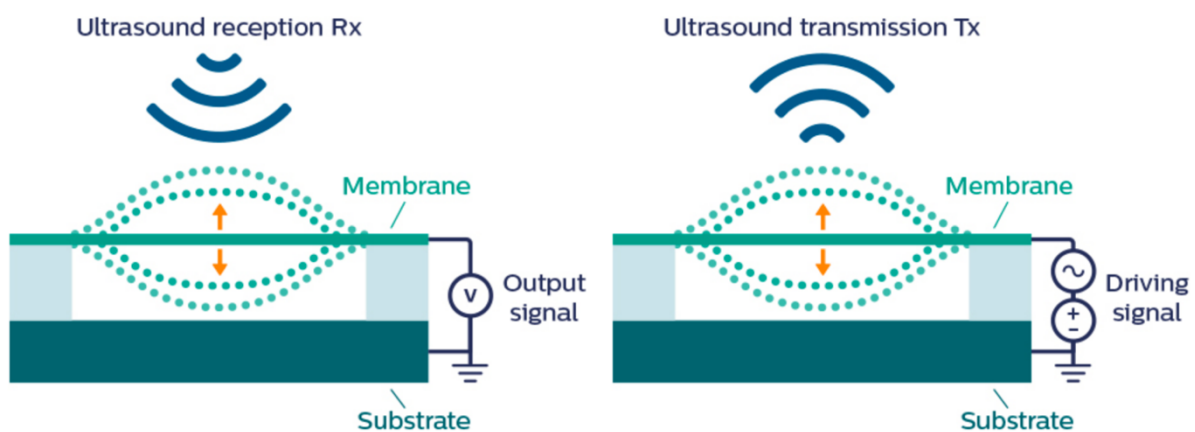

Figure 3-1: Overview of the workings of a CMUT. [16]

The CMUT consists mainly of three components, the membrane, the cavity and the substrate (Figure 3-1). CMUTs are made of silicon, produced using micro-machining. The top electrode/membrane is a thin layer covered in conductive material suspended over a cavity and the bottom electrode/substrate. The substrate is heavily doped, which is separated from the



membrane by silicon as insulation to prevent short-circuiting. There is a DC-voltage bias between the top and bottom electrode, pulling the membrane towards the substrate. When applying a AC-voltage to the membrane, harmonic motion of the membrane is attained. When the CMUT is in receiving mode, ultrasonic waves causes the membrane to vibrate, producing a change in capacitance which then is monitored. When transmitting, an AC signal is applied to both the electrodes making the top electrode vibrate and send out ultrasonic waves (Figure 3-1). [16] [13] [17]

These CMUT structures can be set up in any geometry and can therefore be made into any array shape that is needed to perform a given task [13]. The dimension difference of a 1D and 2D array can be seen in Figure 3-2, as well as a 1D set-up of CMUT cells.

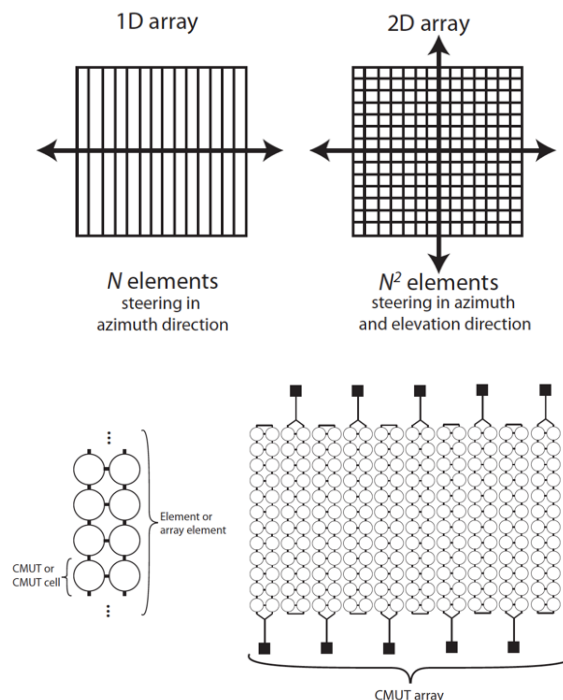

Figure 3-2: Difference between 1D and 2D array and an example: CMUT cells set in a 1-dimension linear array. [13]

## 3.2 PARTICLE PROPERTIES

Particle properties are essential to understand in order to measure particle matter correctly. There is both powder and particle properties that need to be addressed to get an accurate picture of how different particles behave. Measuring the right particle size can be quite difficult especially when the particle has a non-spherical geometric shape. Further size range, distribution, dispersion and motion are some properties that need to be reviewed. Not all properties are review and only properties relevant for air/gaseous environments are taken into consideration.

### 3.2.1 SIZE, SHAPE AND RANGE

The size of a particle is the primary property determining its transport capabilities. The size of a particle is often given by particle diameter. The geometric shape of a particle can vary a lot, from a spherical particle to an elongated square and measuring them is all the more difficult. The size of a spherical particle can be defined by one number, the diameter. A non-spherical particle need several measurements to be accurately described (Figure 3-3) The most common method for particle size distribution instruments is to give non-spherical particles an “equivalent spherical diameter”. This means a sphere with the same volume as the given particle [18, 19]. One of the problems with this approach is if the particle has a large aspect ratio between width and height. This will make it hard for some instruments to get a correct result. In such a case instruments that can see the shape of the particle may be preferable. [19]

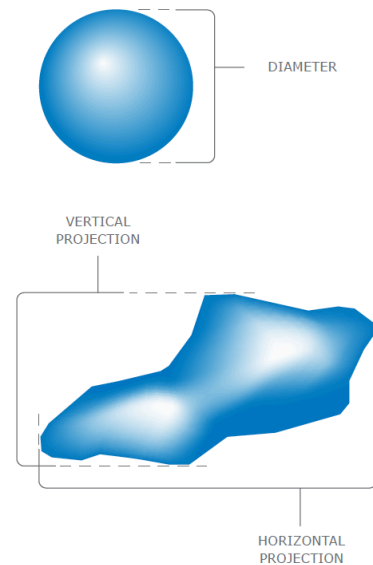

*Figure 3-3: Overview of the difference in particle size measurement for spherical vs non-spherical. [19]*

The shape of a particle affects both its aerodynamics abilities and dispersion behaviour, making it a central property when determining its transport capabilities. The shape of particles is mostly based on how it is formed, changes in particle shape will also occur by crystallization, hydration and most important agglomeration. Agglomeration is a process where particles cluster together because of their material properties, environment conditions and means of storage, making three types of particles. These exist because of different interparticle forces and bindings [18]. The three types are presented below (Figure 3-4):

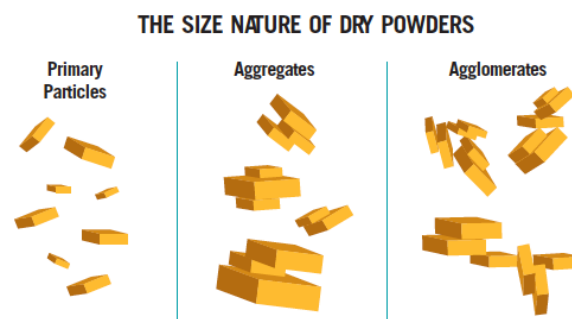

*Figure 3-4: Overview of the difference between primary, aggregate and agglomerate particles. [10]*

**Primary particles:** This is the fundamental particles, the particles held together by molecular or atomic bonds. They cannot be divided into smaller particles without the application of high amounts of energy.

**Aggregates:** These particles consist of two or more primary particles, which is fairly tight bound by interparticle forces, like the solid bridge force (described in chapter 3.2.1). They need quite a force to separate back into primary particles.

**Agglomerates:** These particles are clusters of aggregates lightly held together by van der Waals force, electromagnetic force, friction and interlocking (described in chapter 3.2.1). These cluster can more easily be broken apart.

Because particles can cluster together creating aggregates and agglomerates, a variety of sizes can be created within the same particle type. This size distribution for a number of particles types can be seen in Figure 3-5. For example atmospheric dust has a size range from 0.075  $\mu\text{m}$  to 7.5  $\mu\text{m}$ , depending on how they are put together.

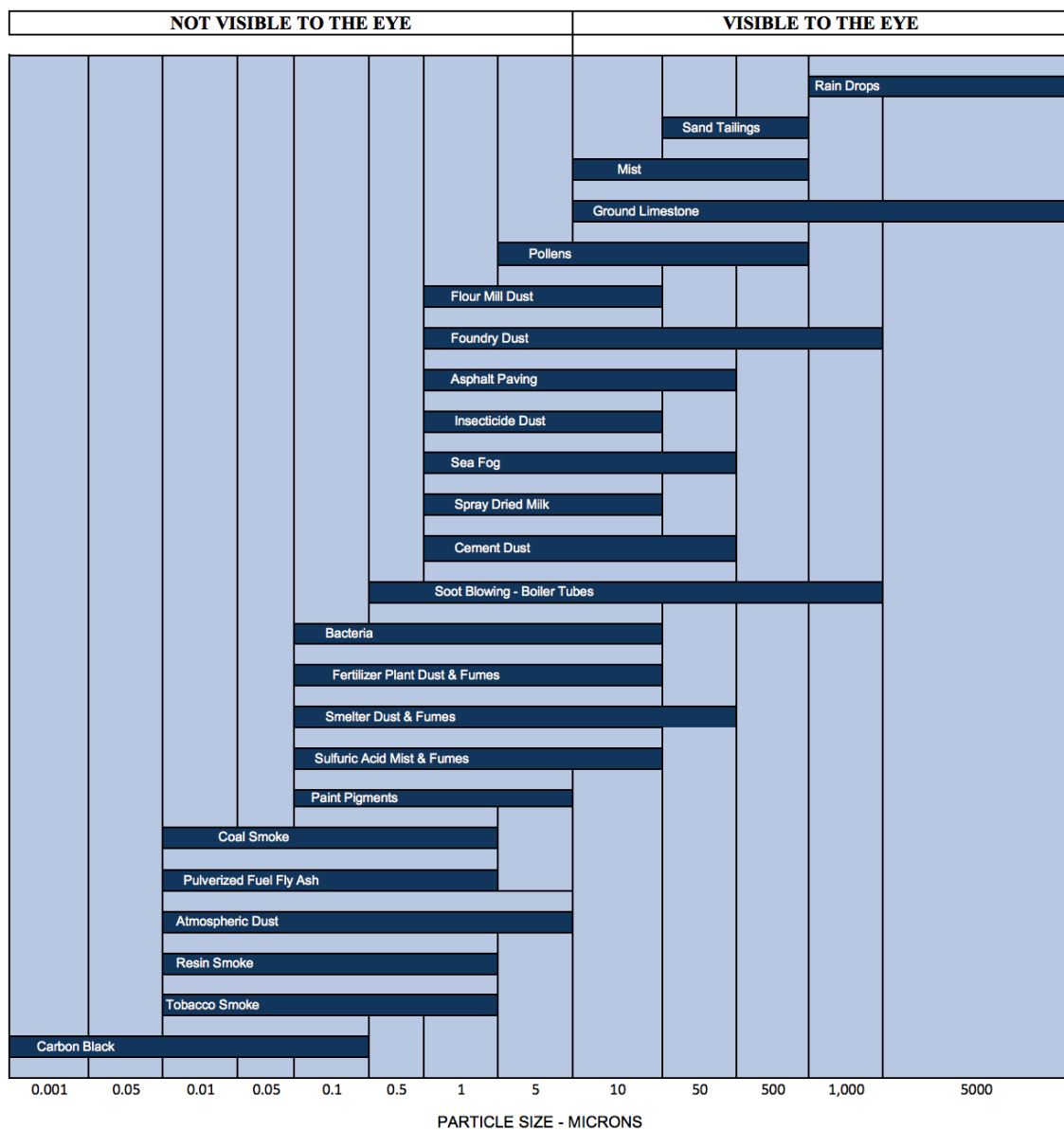

Figure 3-5: Particle size range for a chosen sample of particles. [20]

### 3.2.2 DISTRIBUTION

A monodispersed aerosol is a cloud consisting of same size particles. However, the ambient air surrounding all humans around the world contain a wide range of particles. For each particle type there is an unique size distribution because of its specific attributes and properties. A cloud of different sized particles are called polydispersed aerosol. The particle size distribution of these polydispersed aerosols describe the characteristics of the cloud of multi-size particles. The size distribution for a polydispersed aerosol is usually unevenly distributed. This uneven distribution can be seen in Figure 3-6. In aerosols, large agglomerate particles often break up into smaller aggregates and primary particles often cluster together, making this skewed or Gaussian distribution. [21] Knowing how the size distribution shown in Figure 3-6 will be for different particles, is essential information into understanding the characteristics of particle matter.

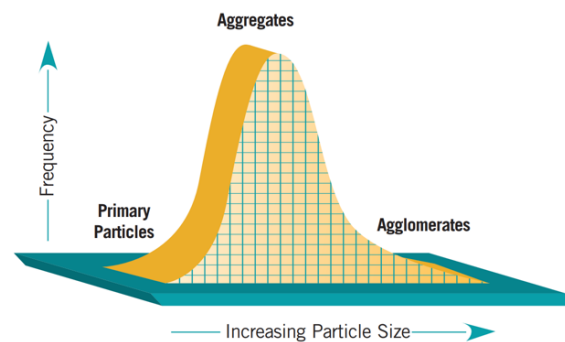

Figure 3-6: General particle size distribution for particles in outdoor air. [18]

### 3.2.3 HYDROPHOBIC VS HYDROPHILIC PARTICLES

The difference between hydrophobic and hydrophilic particles is how the particles interaction with water, if the particle has an attraction to water or not. A fully hydrophobic particle has the property that it has no attraction to water. This gives it the ability to be in contact with water or humid air without changing size or shape, though agglomeration may occur. Hydrophilic particles is at the opposite side having an attraction to water, which will make it more vulnerable to water or humid air, changing its size and having a higher probability of agglomeration. Most particles are somewhere in-between these outer points [22].

### 3.2.4 PARTICLE MOVEMENT - BROWNIAN MOTION

Brownian motion was discovered by Robert Brown in 1827 and is the random movement of microscopic particles in either gas or liquid. It is caused by constant bombardment of molecules in the gas/liquid. The particle motion can be clearly seen with the use of a microscope. [23]

### 3.3 PARTICLE DISPERSION

Dispersion of particles from bulk powder is the process of shattering aggregate and agglomerate particle cluster down to their original primary particle form. This is done by applying different external forces to tear the clustered particles apart, overcoming the cohesive/interparticle forces acting on the particles [24]. There are two main dispersion methods, wet and dry dispersion. Dry meaning dispersed from dry bulk powder. Wet meaning dispersion of suspensions, emulsions, gels, etc [25] [26].

The dispersion of particles, especially of highly cohesive particles is an important method used in a number of industries like pharmaceuticals, production of bulk chemicals and the food industry [24]. In pharmaceuticals getting the particles dispersed correctly is essential in getting the correct result that the product is intended to give. [27] It is also used when researching the effect particle dispersion in ambient air can have on people's health. Using dispersion to de-agglomerate particles, for then to see if and how the particles cluster together under different conditions can give an overview of particle properties. How long it stays suspended and how it may affect people. All depended on how particles interact with each other and cluster. [22] [25]

Another problem with dispersion, is adhesive forces. The forces acting between dissimilar particles or surfaces, which can be mechanical or electrostatic forces. Adhesive forces can make particles stick to surfaces because of difference in electrical charge, making it stick to the wall inside the dispersion device etc. [28]

#### 3.3.1 INTERPARTICLE ATTRACTION

To be able to get a sufficient dispersion of bulk powder into primary particles, two essential forces need to be overcome to completely disintegrate the particle clusters into primary particles. Which is the bulk tensile strength and shear strength. These forces can then again split up into more specific forces which is listed below from strongest to weakest as well as the interlocking that may occur [24]:

##### **FORCES**

- Solid bridge forces
- Liquid bridge forces
- Van der Waals
- Electrostatic
- Magnetic

##### **INTERLOCKING**

- Mechanical interlocking
- Polymer brush

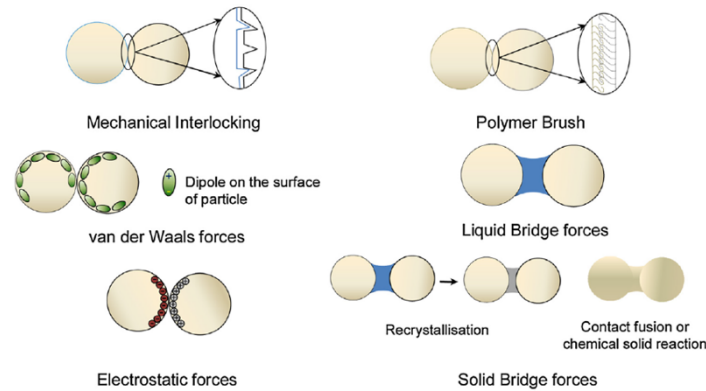

Figure 3-7: Explanation of the different interparticle forces, as well as mechanical interlocking. [27]

To perform a successful aerodynamic dispersion, enough external separation force need to be introduced to overpower the interparticle forces of the bulk powder (Figure 3-7). Doing so will make it possible to produce a dispersed cloud of primary particles. Factors that have an impact on these forces and on the interlocking are particle shape and size, the packing structure, surface area, porosity and the interparticle forces mentioned above. [24] Lastly a particle with polymer brush or coating makes the particles cluster easily as they have long strands stick out from them [29].

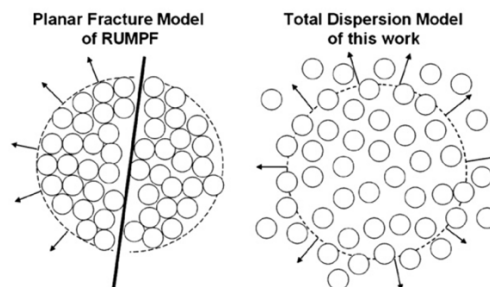

Figure 3-8: Illustration of Rumpfs planar fracture model and a total dispersion model. [30]

There are mainly two theoretical approaches describing the stability of agglomerated particles. One multi-particle approach and one two-particle approach. The first assumes agglomerates with several primary particles and the other only two particles, both makes the simplification that the particles are spherically shaped. The two-particle approach has a drawback as it cannot directly describe a multi-particle agglomerate directly. The Rumpf planar fracture model describes the mechanical stability multi-particle aggregates/agglomerates have and the force needed to pull the particle structure into two halves, across its cross-section. The tensile strength needed to pull them apart using the Rumpf model (Figure 3-8) is given by: [24] [30]

$$\sigma = \frac{\phi k_n F_{att}}{\pi D_p^2} \quad (3.1)$$

Where the symbols represent:  $\phi$  = Packing fraction,  $F_{att}$  = Interparticle attraction forces,  $k_n$  = Particle coordination number,  $D_p$  = Particle diameter.

Another model presented in “New model describing the total dispersion of dry powder agglomerates” [30] describes a total dispersion model (Figure 3-8), taking all particles in a multi-particle agglomerate into account. The dispersion strength is presented as the force ( $F_{disp}$ ) needed for total dispersion relative to the surface area ( $A_s$ ) of the agglomerate, simply given by:

$$\sigma_{dispersion} = \frac{F_{disp}}{A_s} \tag{3.2}$$

### 3.3.2 DISPERSION TYPES AND MECHANISMS

There are several types of dispersion devices that can accomplish the wanted de-agglomeration of particles. These devices can be described by the following three mechanisms [24]:

1. Dispersion by rapid acceleration or deceleration and/or shear flow.
2. Dispersion of particle clusters by impact onto a stationary or moving target.
3. Dispersion by other mechanical forces (e.g. fluidisation, mixing, vibration and scraping).

Examples of typical powder dispersers using pressurized air, described with dispersion mechanisms and comments taken from “Advance powder technology” [24], are listed in Table 3-1. It is important to note that using to high pressure when dispersing particles, can result in the primary particles breaking. [31]

*Table 3-1: Examples of relevant powder dispersers obtained from Advance powder technology [24].*

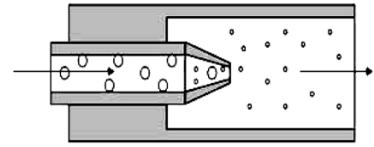
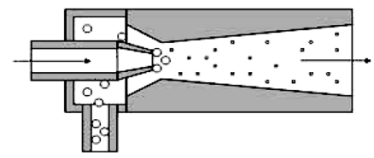
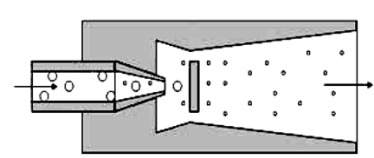
Disperser type	Illustration	Dispersion mechanisms	Comments
Nozzle		Acceleration and/or shear flow Collisions with other particle clusters and device walls.	The powder is already entrained in a pressurised air stream. Therefore, the nozzle may not generate sufficient separating forces.
Ejector		Acceleration and/or shear flow Collisions with other particle clusters and device walls	Powders are dispersed reasonably well due to large relative velocity. May find fine extremely cohesive materials difficult to disperse.
Stationary plate		Acceleration and/or shear flow through the nozzle Impaction on the stationary plate	An addition to the nozzle disperser is to include an impaction plate. This may disperse extremely cohesive materials but is likely to also break particles.

### 3.4 MEASUREMENT TECHNIQUES FOR PM IN AIR

There are several different ways to measure particle concentration and particle types. Only measurement techniques that can measure particle matter in air/gas are taken into account. A selection of methods will be presented to give an overview of the different options that are out there, the remaining methods will be listed. Ending with a technical review of the presented methods, going through their characteristics, strengths and limitations.

#### 3.4.1 SIEVING

Sieving is one of the oldest methods for determining particle size. It is still used to day because of its low price and the ability to determine particle size distribution of a large size range. The method is based on the use of several sieves with different mesh sizes, starting with the largest at the top and having gradually smaller mesh size for each step under (Figure 3-9). This makes the device able to retain a certain size particle for each step, separating the particles into size categories. The amount of sieves can be adjusted according to how exact the testing need to be, but have certain limitations. Each step then need to be analysed to get a distribution result [32].

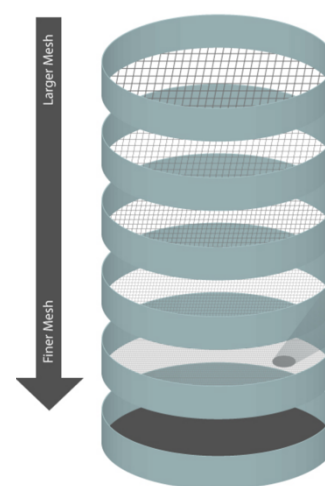

*Figure 3-9: How the sieving method works. [86]*

#### 3.4.2 GRAVIMETRIC

The gravimetric method measures the particle concentration of PM<sub>2.5</sub> or PM<sub>10</sub> for a given period, it cannot measure a wide spectrum of particle sizes. It uses the weight of the accumulated particles in specific sized filters to determine the particle concentration of PM<sub>2.5</sub> or PM<sub>10</sub> for a given period. This is done by weighting the filters used before and after the measurement period. Dividing the weight by the volume of air that has passed the filters, the particle concentration can be calculated. It is similar to sieving but has an air intake, collecting the particles automatic [33] [34].

#### 3.4.3 DYNAMIC IMAGE ANALYSIS

Dynamic image analysis works in a similar way to a modern microscope (Figure 3-10). Fitting a digital camera with special optics, makes it capable of capturing every particle passing within its frame. By continuously taking pictures it can capture the physical properties of every particle passing, which can be both size and shape characteristics. It takes several hundred pictures a second to ensure complete coverage [35] [36].



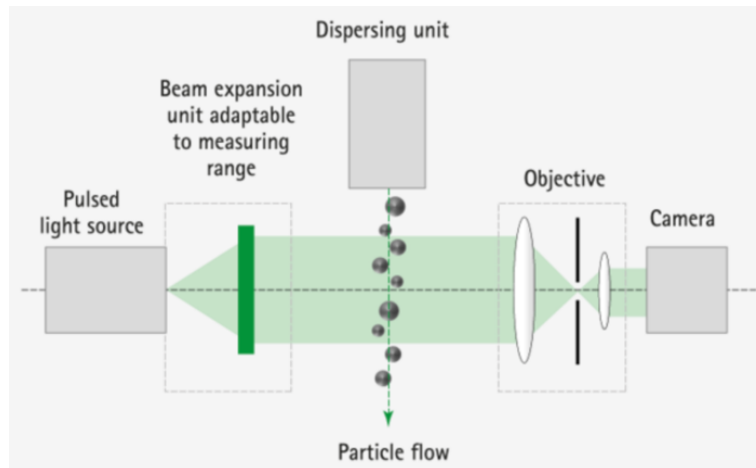

Figure 3-10: An overview of how a dynamic image analysis instrument works. [37]

### 3.4.4 OPTICAL METHODS

The optical methods uses light or lasers to detect particles in the air. When a particle is hit by light it will scatter away from the particle, at the same time some of the light will be transformed into other forms of energy, this is called scattering and absorption. Last there is light extinction which is the combination of these two, measuring the addition of the scattered and absorbed light. [33] The two main optical methods are described below:

#### DYNAMIC LIGHT SCATTERING

Dynamic light scattering or DLS uses the addition of scattered and absorbed light to measure the light extinction that happens when light hits a particle. This is mainly done in fluids, but there are some instruments used for air/gas [35] [36]. Nephelometer and a condensation nucleus counter are instruments that does what is described over in some variation (Figure 3-11). A nephelometer measures the light scattered and absorbed by the particles and subtracts the air/gas, the instrument wall as well as the background noise that can be in the detector. [38] The model shown in Figure 3-11 measures 3 wavelengths to categorize the different particle sizes.

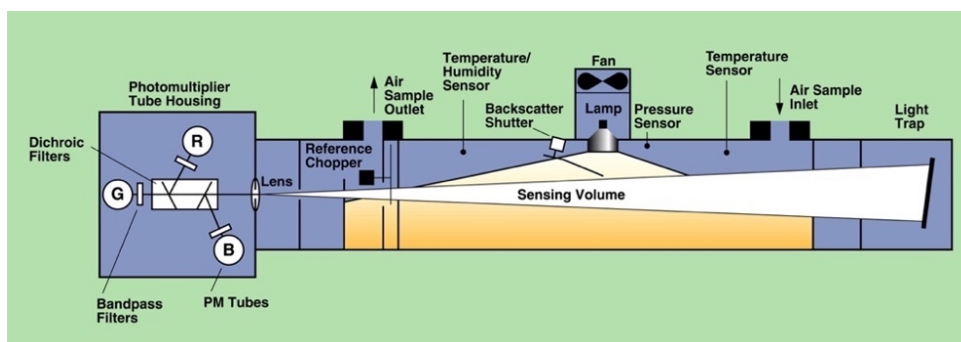
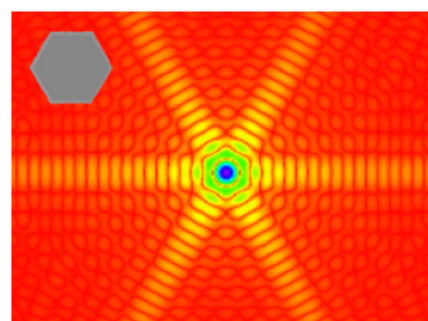

Figure 3-11: TSI 3563 Nephelometer schematic from TSI Incorporated. [38]

## LASER DIFFRACTION

Laser diffraction measures the distribution of particles by monitoring the angular change in light intensity that is being scattered, as a focused laser beam passes the dispersed particles. It is based on the principle that large particles will scatter light with small angles in relation to the laser beam, whereas small particles scatter light with larger angles. The data is then analysed to calculate the particle size distribution that made the specific scatter pattern (Figure 3-12). Laser diffraction uses either Mie theory or Fraunhofer theory of light scattering, depending on the particle sizes. Mie Theory is the most advanced and need to be used for particles under 50 microns in order to get a viable result. [39] [40] [41]



*Figure 3-12: Example of how a hexagonal particle pattern is viewed by a laser diffraction device. [40]*

### 3.4.5 MICROBALANCE RESONANCE METHOD

An oscillating microbalance element uses the change in resonance frequency by passing particles to monitor and determine the PM concentration in the ambient air. Within this measurement technique there is two main instruments, Tapered Element Oscillation Microbalance (TEOM) and Quartz Crystal Microbalance (QCM). [33]

### 3.4.6 OTHER AIR MEASUREMENT METHODS

- Sedimentation/centrifugation
- Electrical mobility
- Adsorption techniques
- Small angle x-ray/Neutron scattering
- Laser-induced Incandescence
- Electron microscopy
- Atomic force microscopy
- Condensation nucleus counter
- Electron diffraction
- X-ray fluorescence
- Beta-ray attenuation
- Electrical aerosol detector

### 3.4.7 TECHNICAL REVIEW OF THE DIFFERENT METHODS

An overview of the size range, simplicity, possible errors, strengths and limitations for the presented methods are listed in Table 3-2. Getting a better understanding of the strength and weaknesses of these techniques. The microbalance resonance method is not included, because of insufficient information.

Table 3-2: Technical review of the different measurement methods. [32] [42] [39] [36] [43] [41]

<b>Sieving</b>	Size range	20 $\mu$ m – 125mm
	Simplicity	Simple, minimal of preparation needed.
	Source of Error	Wrong or no maintenance, risk of agglomeration and fracture of certain particles.
	Strengths	Large size range, simple, cheap, low preparation time
	Limitations	Long analysis time, limited automation and computerization, difficult to recreate results, lacking with high aspect ratio
<b>Gravimetric</b>	Size range	Specific size: PM2.5 or PM10
	Simplicity	Simple, minimal of preparation needed.
	Source of Error	Environmental change, Maintenance
	Strengths	Simple, precise, little instrument error, cheap
	Limitations	Long analysis time, needs chemical analysis for size distribution, high maintenance, narrow range
<b>Dynamic image analysis</b>	Size range	0.8 $\mu$ m – 30mm
	Simplicity	A little comprehensive, calibration the camera etc.
	Source of Error	Maintenance, Calibration
	Strengths	High quality images, high sensitivity, sees shape of particle, fast continuous analysis
	Limitations	Expensive, cannot see ultra-fine particles
<b>Dynamic Light Scattering</b>	Size range	10nm – 5 $\mu$ m
	Simplicity	Relatively simple, need to understand certain principles and algorithm design.
	Source of Error	Maintenance, Calibration
	Strengths	Fast continuous analysis, simple preparation, relatively cheap, do not require high skill level, broad size range, detects smallest particles (10nm)
	Limitations	Expensive for small particle sizes
<b>Laser diffraction</b>	Size range	0.01 $\mu$ m – 8000 $\mu$ m
	Simplicity	Relatively simple, need to understand certain principles and algorithm design.
	Source of Error	Sample preparation, set-up of instruments and operation. Operators accuracy with the instrument, Calibration
	Strengths	Fast continuous analysis, simple preparation, relatively cheap, do not require high skill level, broad size range.
	Limitations	Expensive for small particle sizes



## 4 COMMERCIALY AVAILABLE SENSOR SYSTEMS

---

*This chapter gives a presentation of a representative selection of particle sensor systems for different applications, that are both on the market and under development. This is done to understand the variations within the particle sensor market. Developing a test-rig that takes these variations into account and can be modified to specific use. Further finding reference points for the CMUT sensor.*

There are several particle and air quality sensor solutions on the market. They take different approaches, using different types of technology. Prices are calculated with the currency value for the **date: 03.04.2018**. Contact has been made to all manufactures listed below in regard to price. “Price requested” is listed on the systems where the manufacturer has not responded or was not willing to disclose price.

### 4.1 INDUSTRIAL PARTICLE SENSOR SYSTEMS

A representative selection of sensor systems that are on the market is listed in this chapter. Showing where the industry is today in developing sensor solutions and systems. All sensor systems listed below can measure humidity, temperature and pressure, in addition to particle matter. These industrial systems have a high accuracy when tested in a comparison trail with a reference equipment. The technical information for each system is listed at the end of each sub-chapter. For a more in-depth understanding then this, datasheets for all systems is referenced.

#### 4.1.1 GRIMM – EDM365 & EDM665

Grimm delivers a wide range of air quality sensors and particle sensors. Having choices between handheld, mobile and stationary models. To get an overview of what they have to offer two sensor types are presented, one mobile (EDM365) and one stationary (EDM665), presented in Figure 4-1. These are high performance particles sensors meant for high accuracy air quality measurements.

The EDM 665 is the flagship model providing 71 size channels, for accurate measurements. The EDM365 is a smaller and more course detector, providing 31 size channels. These sensors are meant for long measurement periods and is built to last. The different specifications can be seen in Table 4-1. [44] [45]

Table 4-1: Specifications for the EDM365 and EDM665 sensor systems. [45] [44]

Specification	EDM365	EDM665
Use	Mobile aerosol monitor	Stationary aerosol monitor
Market	Process and environment	Process and environment
Particle size range	0.25 $\mu\text{m}$ – 32 $\mu\text{m}$	5 nm - 32 $\mu\text{m}$
Concentration range	0 – 2,000,000 particles/l	0 – 2,000,000 particles/l
Sensor type/types	Laser scattering	Laser scattering, Differential mobility analysis, Condensation nucleus counter
Measurement options	Particles	Particles
Size	80x60x40 cm	80x80x160 cm
Weight	25 kg	250 kg
Price	Price requested	Price requested

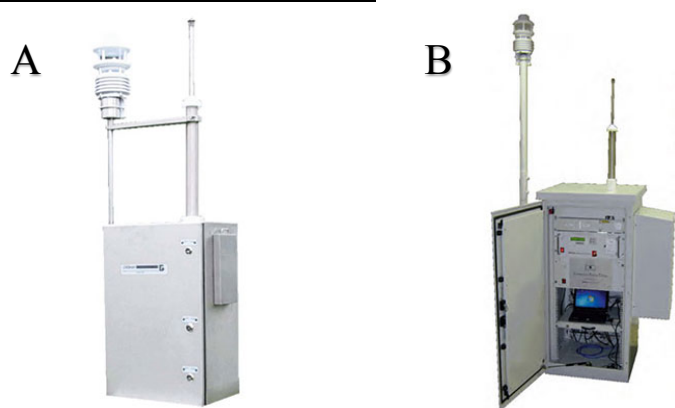

Figure 4-1: Image of: A: The EDM365 and B: the EDM665 sensor systems. [46] [47]

#### 4.1.2 OTHER COMPETING SENSOR SYSTEMS

These sensors represent the diversity of companies in the industrial sensor system market. All the technical specifications for the systems are in Table 4-2.

##### HORIBA – PX-375

The Horiba PX-375 is a high performance particulate monitor with continuous analysis of particulate mass concentration and element concentration. It does automatic sampling, continuous online PM quantitative and qualitative analysis and rapid air pollution source appointment (Figure 4-2). It measures a vast amount of elements including: S, Ti, Cr, Mn, Ni, Cu, Zn, Pb, Al, Si, K, Ca, V, Fe, As. This is possible by being able to switch between light and heavy metal detection. [48]

##### AEROQUAL – DUST PROFILER

The Aeroqual Dust profiler is a high performance continuous dust and particle counter. It is mobile and able to run on remote power sources, it does automatic sampling and has a 20 year on-board data storage (Figure 4-2). It can connect both to your computer and a cloud based service. It also has the option to be fitted with environmental sensors like, wind, solar, weather etc. [49]

**AQMesh**

AQmesh is a wireless system for measuring outdoor air quality and does not need a power supply, as it has on-board batteries giving it 2 years of power (Figure 4-2). It can monitor a range of particle size as well as a vast range of gases. It is a small device compared to most of the other industrial sensor systems making it easy to mount in a variety of places. The sensor is connected up against a server/cloud, making it possible to correct for environmental factors online. [50]

*Table 4-2: Specifications on the Horiba PX-375, Aeroqual dust profiler and AQMesh. [48] [49] [50]*

Specification	PX-375	Dust profiler	AQMesh
Use	Stationary particulate monitor	Stationary particulate monitor	Stationary particulate monitor
Market	Process and environment	Process and environment	Process and environment
Particle size range	PM10, PM2.5, TSP	PM10, PM2.5, PM1, TSP	PM10, PM2.5, PM1, TSP
Gases/Elements	S, Ti, Cr, Mn, Ni, Cu, Zn, Pb, Al, Si, K, Ca, V, Fe, As	-	NO, NO2, NOx, O3, CO, SO2
Concentration range	0~200/500/1000 $\mu\text{g}/\text{cm}^3$	200-5000 $\mu\text{g}/\text{m}^3$	0-1000 $\mu\text{g}/\text{m}^3$
Sensor type/types	Beta-ray attenuation, Energy dispersive X-ray spectroscopy	Laser scattering	Laser scattering, electrochemical sensors
Measurement options	Particles, elements	Particles	Particles, gases
Size	430x550x285 mm (Without sampling pipe and head)	483x330x187 mm	170x220x250 mm (without antenna)
Weight	40 kg	13 kg	2 – 2.7 kg
Price	Price requested	78.338 NOK (10.000 \$)	78.338 NOK (10.000 \$)

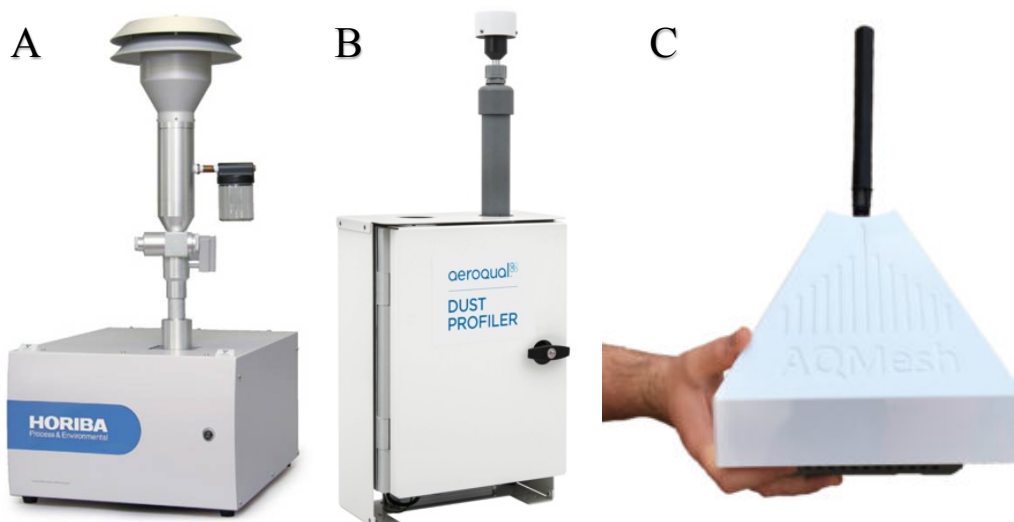

*Figure 4-2: Sensor systems: A: Horiba PX-375, B: Aeroqual Dust Profiler, C: AQMesh. [51] [49] [48]*

### 4.1.3 HANDHELD SENSOR SYSTEMS

Handheld sensors is also an option when monitoring particle matter. Here, two different sensors is reviewed. Technical specifications for the systems are in Table 4-3.

#### NANEOS – PARTECTOR AEROSOL DOSIMETER

The Partector developed by Naneos is the world's smallest nanoparticle detector according to them (Figure 4-3). It uses LDSA (Lug deposition surface area) measurement, a method that is used to measure the harmful effects on respiratory health. It takes into account that smaller particles more easily get deposited in the lungs and also amounts to a larger surface area per particle, making them more harmful. It uses electrical diffusion for particle detection, with a data analysis tool. It has a large size range for measure making it possible to use in a variety of situations [52] [53].

#### AEROQUAL – PORTABLE AIR QUALITY MONITOR

This portable air quality monitor has the ability to switch out the measurement part, with 27 different interchangeable gas and particle sensors (Blue part, Figure 4-3). This makes it able to measure a wide range of particles and gases, adapting to several different situations. It continuously measures pollutants, logging it for latter analyzation [54].

Table 4-3: Specifications on the Naneos Partector and Aeroqual portable. [52] [55]

Specification	Partector	Aeroqual Portable
Use	Portable exposure monitor	Portable exposure monitor
Market	Personal/industry	Personal/industry
Particle size range	10nm - 10 $\mu$ m	PM2.5, PM10
Concentration range	1-20.000 $\mu$ m <sup>2</sup> /cm <sup>3</sup>	0,001-1 mg/m <sup>3</sup>
Sensor type/types	Electrical diffusion	Laser scattering
Measurement possibilities	Particles	Particles, gases
Size	134x78x29 mm	-
Weight	400 g	-
Price	56.756 NOK (6.900 CHF)	5875 NOK (750 \$)

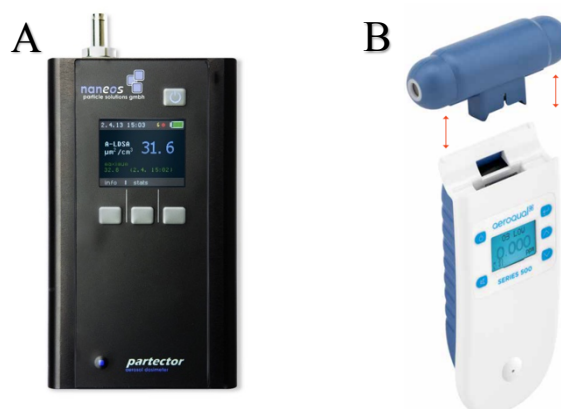

Figure 4-3: Sensors: A: Naneos Partector, B: Aeroqual Portable Air Quality Monitor. [53] [50]



## 4.2 PRIVATE INDOOR MARKET

There is also a growing market for indoor air quality sensors. People are getting more and more aware that the air around them is not necessarily clean and wants a product which can tell them the air quality in their own house. Ohoo air quality monitor is the only one presented as the different monitors have a price range between 100-300 \$, with small variances in specifications. Examples of other manufacturers are Awair and Foobot.

### 4.2.1 UHOO

Uhoo have developed an indoor air toxin sensor on the high end side of the price range, which can be put anywhere inside the house (Table 4-4). The data gathered by the sensor can be monitored using an app on your smartphone. Further it has an alarm system that alert the residents if the pollution level is too high, so they can take appropriate measures. Uhoo say it is ultra-portable. It can measure the following: Temperature, Humidity, PM2.5, VOCs, Air pressure, Carbon dioxide, Carbon monoxide, Nitrogen dioxide, ozone. [56]

Table 4-4: Picture and specification for the Uhoo Air Quality Sensor. [56]

	Specifications	
	Use	Indoor
Market	Personal, private	
Particle size range	-	
Concentration range	1-200 $\mu\text{g}/\text{m}^3$	
Sensor type/types	-	
Measurement possibilities	Particles, gases	
Size	250x125x82 mm	
Weight	710 g	
Price	2346 NOK (299\$)	

## 4.3 SIMPLE AND INEXPENSIVE PARTICLE SENSORS

In addition to the expensive sensor systems, there is also a large market for inexpensive sensors available online, not including a complete system but sold as just a sensor. Three different sensors (Figure 4-4) are listed below to give an indication of what is on the market (Table 4-5). These sensor have higher inaccuracies, something that is expected with the price point. These are small and compact, used mainly together with the Arduino prototyping platform or similar in order to retrieve and understand the data transmitted from the sensors.

Table 4-5: Specifications on: Nova fitness SDS021, Plantower PMS5003, Honeywell HPM Series. [57] [58] [59] [60]

	<b>Nova fitness SDS021</b>	<b>Plantower PMS5003</b>	<b>Honeywell HPMA-115S0</b>
Specification	Value/type	Value/type	Value/type
Use	Portable	Portable	Portable
Market	Personal	Personal	Personal
Particle size range	-	-	-
Concentration range	0-999.9 $\mu\text{g}/\text{m}^3$	0-1000 $\mu\text{g}/\text{m}^3$	0-1000 $\mu\text{g}/\text{m}^3$
Sensor type/types	Laser scattering	Light scattering	Laser scattering
Measurement possibilities	PM2.5, PM10	PM1, PM2.5, PM10	PM2.5, PM10
Size	42.5x32x24.5 mm	50x38x21 mm	43x36x23.7 mm
Weight	-	-	40 g
Price	314 NOK (39.95\$)	314 NOK (39.95\$)	184 NOK (23,46\$)



Figure 4-4: An overview over three simple inexpensive particle sensors: A: Nova fitness SDS021 B: Plantower PMS5003, C: Honeywell HPM Series. [57] [60] [59]

## 4.4 IN DEVELOPMENT

Interesting sensor systems that are under development is listed in this chapter. Showing possible innovative sensor systems coming in the next years.

### 4.4.1 CHEMISENSE

This start-up company is developing a wearable sensor for asthmatics or people in general how are concerned about the air they breathe. Combining the sensor with a mobile app the goal is to be able to see harmful particles and toxins that surround you, and from there take appropriate measures to prevent being exposed to these toxins. By connecting all device to a cloud the goal is to be able to share each individual pollution levels, so people can avoid specific areas that has a high concentration at that given time. [61, 62]

The ChemiSense uses chemiresistor sensors, which imitates a highly-evolved nose and is design specially to pick up certain unwanted gases and particles. It is made up of polymer with charged nano carbon particles (Figure 4-5). The particles will expand in size in contact with certain gases, changing the resistance in the circuit board and making to possible to sense them. [61]



*Figure 4-5: ChemiSense's prototype sensors detect the presents of airborne particles. It can be used as an arm band. [61] [63]*

They hope that the Chemisense will be able to detect a large number of different gases and particles including [62]: Volatile Organic Compounds, Carbon Monoxide (CO), Nitrogen Dioxide (NO<sub>2</sub>), Ammonia (NH<sub>3</sub>), Formaldehyde (CH<sub>2</sub>O) and Particulate matter: PM2.5 & PM10.

## 4.5 SENSOR SUMMARY

The market for stationary, mobile and handheld sensors are growing within industrial, environmental and personal use. There is a wide range of systems and products available to purchase with different specifications, like measurement possibilities, sensor types, lifespan and accuracy. The increasing focus on adverse effects connected to air quality, puts a pressure on the industry, especially to monitor and reduce harmful emissions. Further making the general population wanting to monitor their own homes and ambient air to ensure that the air they are breathing is not harmful.

### POSSIBLE AREAS OF IMPROVEMENT & CONSIDERATIONS

As seen, there is a steep price increase when reducing the size of the particles that the sensor can measure. Having a sensor that has the possibility to measure ultra-fine particles down towards 10nm in a lower price category as the Stanford group is trying to do, would be appealing. Further being able to produce a sensor that can be configured to both an industrial setting and for personal use. The private indoor market has a large potential when it comes to informing the costumer on what they are actually buying. An indoor air quality monitor that has the documentation stating that it is properly tested is lacking.

It is important to take into consideration the alternatives within the sensor system market when developing the test-rig. Build design, sensor type, price etc. are all factors that need to be addressed in order to assemble a rig that can be utilized to its full potential.

## **TEST-RIG DEVELOPMENT**

THE AIM OF THIS THESIS IS TO DEVELOP A TEST-RIG FOR PARTICLE SENSOR TESTING AND FUTURE EVALUATION OF THE CMUT SENSOR. THE NEXT CHAPTERS OF THIS THESIS IS DIVIDED IN TO TWO PARTS. WHICH INCLUDES A WALK TROUGH OF THE DEVELOPMENT OF THE TEST-RIG, FROM EARLY CONCEPTS TO FINAL ASSEMBLY AND TESTING. ENDING WITH AN EVALUATION, CONCLUSION AND FUTURE WORK.

**PART ONE: EARLY DEVELOPMENT, SIMULATION & SELECTION**

**PART TWO: TESTING**

## PART ONE: EARLY DEVELOPMENT, SIMULATION &amp; SELECTION

## 5 CONCEPTUALIZATION

*In this chapter the early development phase of the test-rig will be presented where the aim is to create a viable test-rig that can be utilized by the Stanford group. To create a sustainable system a review of the current test-rig and tested setups will be presented, ending in setting the specifications for the test-rig. Based on data gathered from this section a further conceptualization and layout review will be conducted.*

### 5.1 CURRENT TEST-RIG

The current setup for the test-rig is of a simple design, seen in Figure 5-1. The new test-rig is going to be based on this setup, as more complete build. It consist of a clear pipe, that makes up the particle distribution area (test chamber). The sensor is mounted by cutting into the pipe at the same high as the polycarbonate plate the sensor is fasted to, and just through so the sensor has clear access to the test chamber. This is done so the material does not cause interference on the sensor. This is the same way the particle sensor will be mounted on to the new rig.

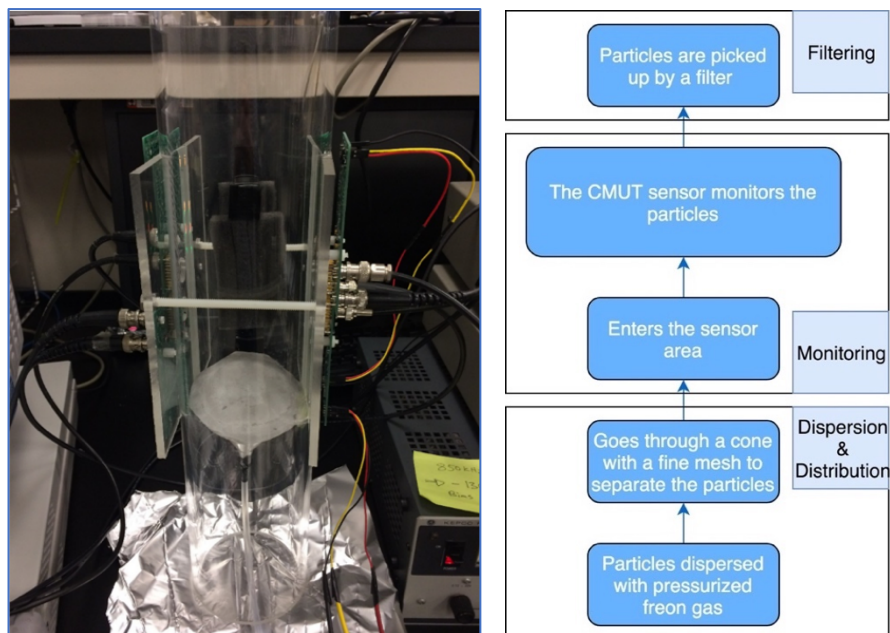

*Figure 5-1: The current test-rig for the CMUT particle sensor, with a flowchart to describe the process.*

The dispersion and distribution device consist of pressurized freon gas, that is used to disperse the particles. Further a funnel is placed at the end of the narrow freon gas pipe, where a 60  $\mu\text{m}$  wire mesh is placed on top. This is used to distribute the particles into the test chamber. There

are no filters over the transducers (sensors) because bias voltage applied to both of them should prevent particles from being electrostatically attracted to the sensor.

### PROBLEMS WITH CURRENT TEST-RIG

- **Dispersion:** The test-rig has problems dispersing the particles. The aggregate and agglomerate particle clusters that can be created in a particle powder, is not being broken into primary particles as desired. Making the size of the particles incorrect and giving the data gathered inaccuracies.
- **Distribution:** The distribution of particles is not as uniform as wanted.
- **Flow:** The current test-rig has no control of the flow after the particles have entered the test chamber.

## 5.2 TESTED SETUPS FROM OTHER STUDIES

To be able to compare the developed test-rig specifications and results, a well-tested setup from another study is presented. The components and principles used in this study may be applicable for further research and development. The U.S Environmental protection agency have also conducted several tests of low-cost sensors in the field [64], which can possibly be used at a later stage of the sensor testing.

### 5.2.1 ACCURACY STUDIES OF LOW-COST PARTICLE SENSORS

A common test setup for testing the accuracy of low-cost particle sensors is presented below (Figure 5-2). It uses high-end instruments to accurately disperse the particles using a TSI Aerosol Generator 3076 with a constant particle diameter output. Used together with a diffusion dryer (removing particle water content). The dispersion dryer is used because the 3076 uses wet dispersion, and the liquid need to be removed. The particles are dispersed into the test chamber where the low-cost particle sensor (Sharp GP2Y) can monitor the particles. To determine if the measurements are correct, a SMPS (Scanning Mobility Particle Sizer) is used to compare the results [65] [66].

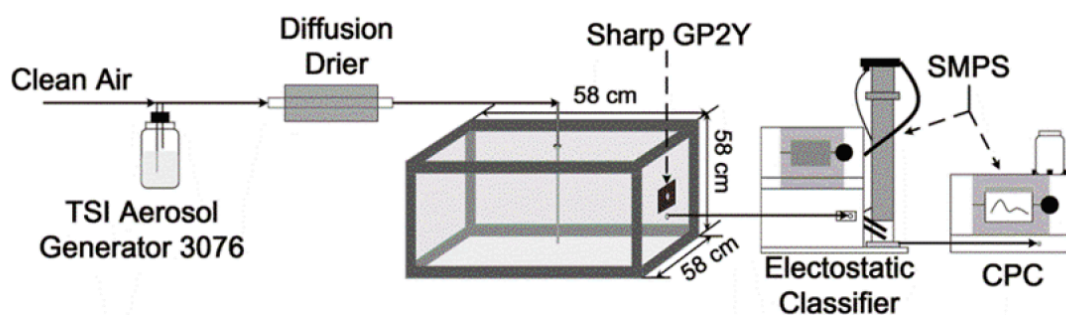
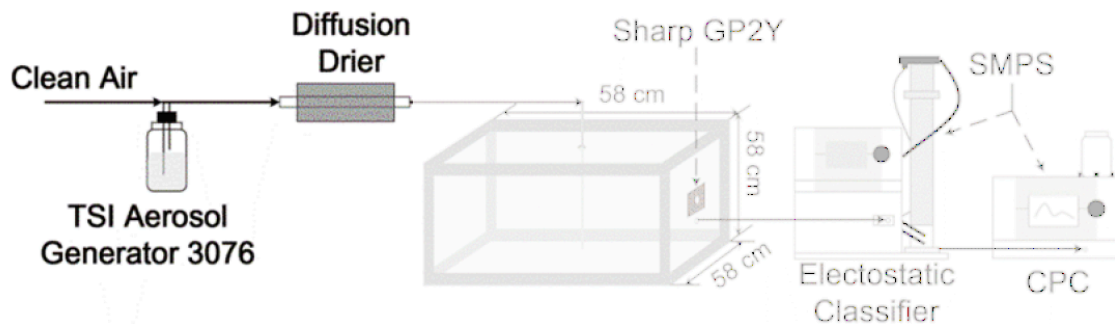

Figure 5-2: Test setup often used to test low-cost particle sensors. [65]

After having been in contact with a sales specialist within particle instruments from TSI discussing the aforementioned test setup, a price was estimated. A complete dispersion system with the TSI aerosol generator 3076, a diffusion dryer and a pressurized air setup would cost 7-15,000 euros and the SMPS, 60-90,000 euros. In worst case, the whole rig would cost 105,000 euros or over a million NOK. This is a highly expensive setup, which makes it a non-viable option for this project. For this project an inexpensive dry dispersion version of the aerosol generator and diffusion dryer is going to be developed (Figure 5-3).



*Figure 5-3: The tested setup with the relevant equipment that is going to be developed using inexpensive equipment, is highlighted.*

### 5.2.2 UTILIZATION OF TESTED SETUP

The setup described above is far outside the budget limitations set for this thesis, but certain elements from the setup may be included in the development process. By taking the principles used in this setup and researching similar low-cost solutions/methods that can be utilized. Elements to utilize in development:

- A aerosol generator/dispersion device.
- Use particle data from other studies to compare with own data.
- A SMPS may need to be bought in to have a high quality reference point.

## 5.3 TEST-RIG SPECIFICATIONS

The goals and requirements for the development process will be set in this chapter. The current test-rig, relevant principles and solution from the tested setup (6.2.1) and chapter 4 will be used in the development of the test-rig. Through the specifications, actions/goals are going to be set to fix the problems stated for the current test-rig.

In order to fulfil the main objective in an optimal manner, the test-rig end developments result should be a rig that can assistance and make further development of the CMUT possible. Characteristics like compatibility and interchangeability should be sought after to maximize the

use of the rig, making it possible to set it up to fit the tests needed. The rig should be able to be assembled in different ways to perform the processes listed underneath (further explained in chapter 5.4). To ensure the multipurpose use for different sensors and different types of particle sources.

1. Natural convection, start-end
2. Force convection, start-end
3. Force convection, looped

#### REQUIREMENTS

- **Compatibility** shall be a priority through the development, ensuring that the design of the assembly does not get too specific. Making it compatible for different sensors.
- **Interchangeability** shall be a priority through the development, ensuring that the test-rig can be adjusted to incorporate new parts. Making it possible to perform different types of test and further ensuring the compatibility of the rig.
- **Electrical conductivity** needs to be taken into account, as several particle types lead electricity and can therefore interfere with the electronic equipment.

#### 5.3.1 GOALS

*Overall goal: This thesis aims to make an inexpensive test-rig for particle sensor testing. The rig shall be able to create a uniformly distributed and suspended particle flow, and suitable particles with a uniform size shall be identified, and be used for testing. To do so it should fulfil the goals set below:*

- **The rig layout** shall be built in a way that it is multifunctional.
- **The rig layout** shall be interchangeable so parts can be changed or altered if needed.
- **The rig layout** need to be design taking into account the mount of the CMUT sensor.
- The rig shall **distribute** the particles uniformly over the cross-section of the sensor area.
- **Flow analysis** shall be thoroughly conducted to produce a well evaluated distribution solution. Further testing the effect flow direction and gravity has on the particles.
- It shall be possible to **adjust the flow** in the system, enabling the possibility of having different flow characteristics depending on the test wanted.
- Suitable low-cost **dry dispersion devices** will be examined and selected for testing.
- **Find suitable particles** bought or from a source to use for testing. Both uniformly sized and with a size range.



## 5.4 CONCEPTUALIZATION OF TEST-RIG SETUPS

Based on desired testing possibilities listed and the requirements set earlier, three different preliminary setups are chosen to look further into. All setups are to be interchangeable as per the requirements. Doing so makes it possible to accommodate for the design of the different sensor types. These concepts are not final, but to give an indication for further development.

**Source particles:** Particles emitted/produces by a machine, process etc.

**Manufactured particles:** Particles manufactures by in a laboratory or factory.

### SETUP 1: NATURAL CONVECTION, START-END

This is the simplest setup, using natural convection of particles from a source to produce a particle cloud for the sensor. This device (Figure 5-4) can be placed on top of a given source outlet.

- Start-End system
- Complexity: Simple
- Vertical flow
- Experimental reason: Short or long term testing
- Particles: Source

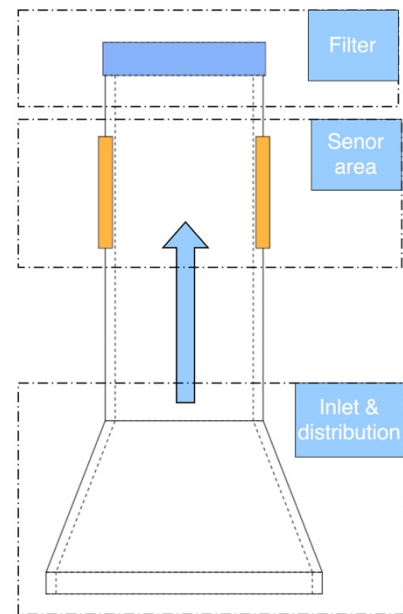
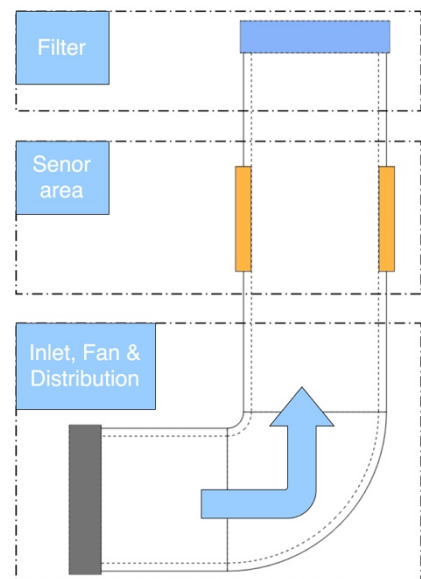

*Figure 5-4: Setup 1, natural convection.*

### SETUP 2: FORCED CONVECTION WITH START-END

By using a dispersion device the particles are transported through a distribution zone, and from there past the sensor area. Further transporting the particles into a filter (Figure 5-5).

- Start-End system
- Complexity: Simple
- Vertical or horizontal flow.
- Experimental reason: Short term testing
- Particles: Source or manufactured particles



*Figure 5-5: Setup 2, Forced convection.*

**SETUP 3: FORCED CONVECTION, LOOPED**

By using a dispersion device the particles are transported by a fan with adjustable speed, through the looped setup. Consisting of a distribution area, a sensor area and a transport area. Using this looped system with a fan, makes it possible to monitor the particles over a longer period of time. It also lowers the amount of particles needed, as the particles can be used several times (Figure 5-6).

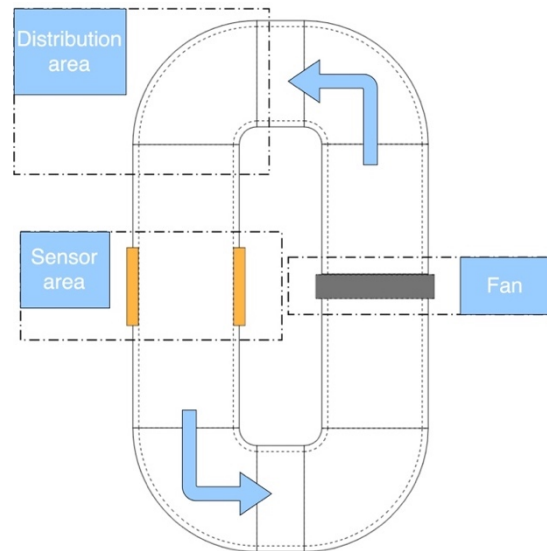

*Figure 5-6: Setup 3, forced convection (looped).*

- Looped system
- Complexity: intermediate
- Vertical or horizontal flow.
- Experimental reason: short or long term testing
- Particles: Source or manufactured particles

In the figures “distribution” and “distribution area” means the area in which a device is need to distribute the particle uniformly before entering the sensor area.

## 5.5 LAYOUT REVIEW

The layout of the rig is the basis on which all the other components will work, using the right layout will make it easier to both develop and implement the different components/solutions. As stated in the limitations, it will if possible be used available materials and/or parts. This imposes certain constraints when choosing how to build the rig.

From both the development goals and the requirements it states that the rig should be interchangeable. Using setup 3 (forced convection, looped) as a base in which the other setups ca be built from, meets these specifications. Setup 3 will therefore consist of modules which can be taken out and put in to form setup 1 and 2.

### 5.5.1 EARLY PARTS SELECTION

Before getting in to flow simulation certain parameter needs to be set in order to limit the simulation span a little. The diameter of the different pipes need to be set, as well as a length area for the pipes.

### SENSOR AREA PIPE

The pipe where the sensor is going to be placed, should be transparent as in the original test-rig so it is possible to see if something happens to the sensor system. A two meter long clear polycarbonate pipe with a diameter of 236 mm was available at the workshop. It matches the criteria's well and can be used to mount the CMUT sensor, and is therefore being selected.

### TRANSPORTATION PIPES & BENDS

The pipes transporting the particles from the sensor area and around does not need to be transparent. The only requirement is that they have a relatively smooth surface inside the pipes, so it does not gather particles. Several aluminium ventilation pipes with a diameter of 125 mm was available at Oak Lab, which had a relatively smooth surface (Figure 5-7). As it coincided with the specifications, it was selected. Because there were suitable ventilation pipes that could be used for the transportation pipes available, equivalent pipe bends was purchased.

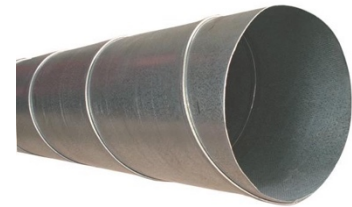

*Figure 5-7: Ventilation pipe available at Oak Lab.*

### DISTRIBUTION DEVICE

Several possible solutions to the distribution section of the development were found, some of them are listed below:

- 3D-printed part, developed through Solidworks flow simulation.
- Mesh with vibration with a device to direct the air.
- Several layers of mesh.
- Hydro cyclone.

Through research and investigation a conclusion was taken that a 3D-printed part was the solution to use. This was based on the fact that it gave the most room for optimization as it would be possible to simulate. Further by using some simple Pugh selection it was arrived at that it would be the most simple, adjustable and easily accessible solution.

## 5.5.2 PRELIMINARY DIMENSIONS

The rig has certain limitations when it comes to dimensions, based on the parts chosen (Table 5-1). In simulation the bends will be made in the same diameter as the transportation pipes.

*Table 5-1: Available pipe length and diameter of the different pipes.*

Part	Available pipe length	Diameter
Sensor area pipe	2000 mm	236 mm
Transportation pipes	5000 mm	125 mm





## 6 COMPONENT REVIEW: HARDWARE & SOFTWARE

*This chapter aims to give an overview of the different components that have been selected. To show why they are selected and what the components do. Further laying forth the proposed component solutions that will be tested.*

### 6.1 FAN SETUP

The fan that is going to be used in the test-rig is a Fractal Design Silent Series R3 (Table 6-1), it was chosen because it was available at Oak Lab, it gave enough flow and had the correct dimensions. The square fan casing has a measure of 140 mm. A way to adjust this fan had to be found. The first idea was to use a potentiometer together with a Arduino, but the Arduino only delivers 5V and the fan has a nominal power input of 12V. It was therefore determined an adjustable power supply (Table 6-1) was a better alternative, it made the solution simpler and made more accurate adjustment possible. By using an adjustable power supply the air speed can be adjusted within a variety of steps. If in addition a relay controlled by a Arduino is connected in-between the fan and power supply an automatic on and off switch can be created. The relay is either open or closed, meaning it either lets the current trough or not, controlled with a signal from the Arduino. This makes it possible to pulsate the air flow through the system, controlling the particle movement even more. Letting them float as suspended particles for a while inside the pipe before turning the fan on again.

*Table 6-1: Specification for the fan and power supply. [67] [68]*

Fractal Design Silent Series R3		
	Nominal input voltage	12 V
	Maximum rate input current	0.12 A
	Maximum air flow	56.1 CFM
	Rotation speed (12V)	1000 RPM
	Size	140x140x25 mm
	Screw hole pattern	125 mm
	Cable length	350 mm
Gopher Technologies CPS-1610C		
	Voltage range	0 – 16 V
	Current range	0 – 10 A
	Power	160 W
	Size	120x55x180 mm
	Adjustable down to 2 decimals	

To mount the fan to the 125 mm pipe a fan holder was designed (Figure 6-1). The fan holder has the same dimensions on the top surface as the fan. As the fan is a square with the dimension of 140 mm, a funnel shape was made down from the top surface for it to fit to a 125 mm ventilation pipe. The circular funnel seen best in Figure 6-1, has an outer diameter of 124 mm giving it a 1 mm clearance.

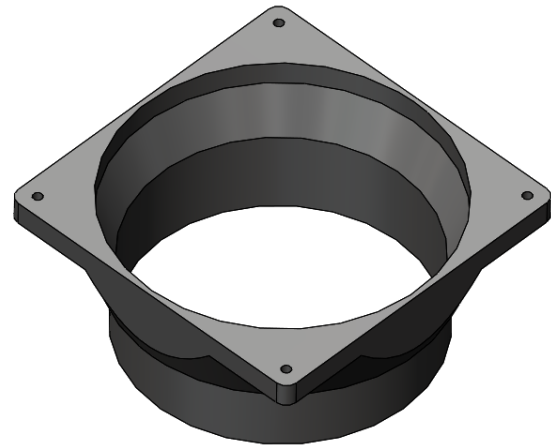

Figure 6-1: The fan holder design.

To make the flow from the fan more linear and therefore less turbulent, a specialized fan plate was made (Figure 6-2). It straightens out the air flow, guiding it in a forward direction. The design is based on the SilverStone Air Penetrator fan and the part was found on the 3D-model site Thingiverse [69]. It is supposed to be placed with the rotational parts in the opposite direction as the fan spins, pushing the rotation air forward instead of a spreading rotational movement (Figure 6-2).

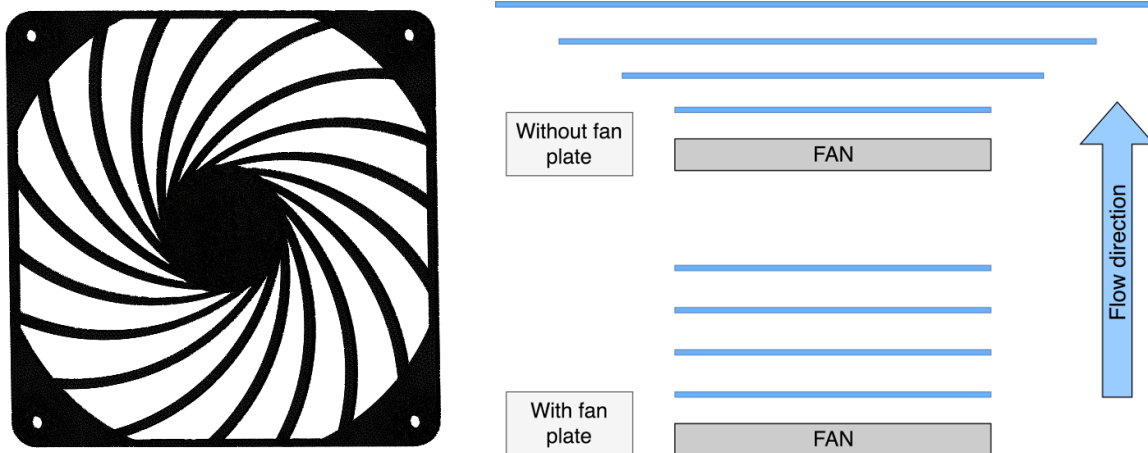

Figure 6-2: Design of the fan plate and conceptualization of how it works. [58]

A full assembly of the fan design is presented in Figure 6-3. The whole assembly can be put together using 4 M5 bolts in each corner with a bolt nut at the other end. Connecting the assembly to a 125 mm ventilation pipe is simply done by sliding the pipe on the outside of the circular end of the fan holders. Where it stops on the edge created 25mm in. A gasket or tape of some sort will be used to seal any dimensional inaccuracies between the two, making it airtight.

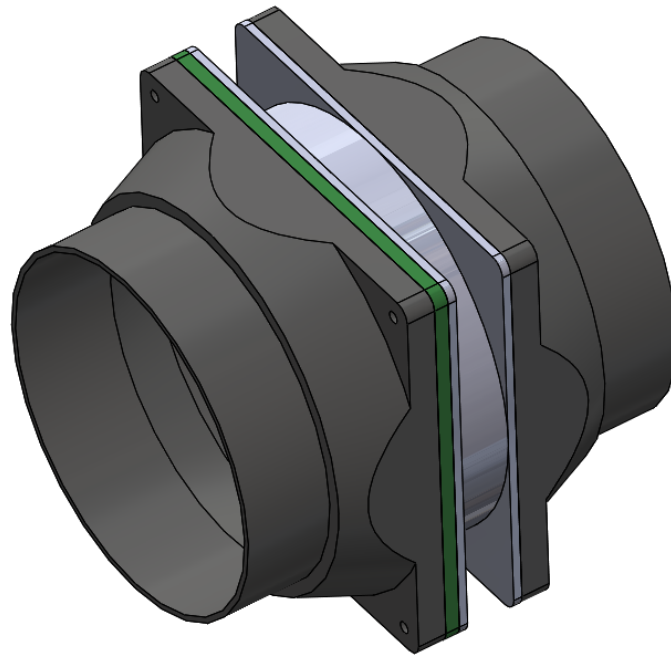

Figure 6-3: The assembly of the fan (light grey), fan holders(dark grey), fan plate (green).

### 6.1.1 THE RELAY SETUP

The relay setup consist of a Arduino Uno board and a 5V relay chip (Table 6-2). The relay is connected to the Arduino's 5V (Red wire) and ground (Black wire) input to get the 5V supply needed from pc/power supply, to turn it on and off. The signal output comes from digital input 7 (Green wire) on the Arduino, it sends a signal turning on and off the relay. The code is set to be on for 8 second and off for 8, done with the code `delay(8000)` meaning milliseconds (Table 6-2). This number can be adjusted to what is preferable individually of each other. The positive source from the adjustable voltage supply, goes through the relay in order to control the fan.

Table 6-2: An overview of the setup of the relay and the code used to control it. The setup has been drawn using the program Fritzing.

Setup	Code
	<pre> #define RELAY1 7 void setup() {   Serial.begin(9600);   pinMode(RELAY1, OUTPUT); } void loop() {   digitalWrite(RELAY1,0); // Turns ON   Serial.println("Light ON");   delay(8000);    digitalWrite(RELAY1,1); // Turns Off   Serial.println("Light OFF");   delay(8000); } </pre>

## 6.2 DISPERSION DEVICES

When using a high quality uniformly sized powder to calibrate a sensor, it is important to ensure that the powder is not clustered. To guarantee a spread of primary particles in the air and not clusters, a dispersion device is needed to ensure de-agglomeration or a breakdown of these clusters to get the particle size that is required. When dry dispersing particles into the air the main method is to do it with the help of a nozzle and pressurized air. After much research into commercially available dispersers specially designed for particle dispersion, it was clear that it would not be possible to purchase one, as it would be too expensive. Therefore an alternative device needs to be tested for use, in order to see if it can break particle clusters down to primary particles without costing too much. In Figure 6-4 two commercially available particle dispersers are presented to get an idea how they are designed. One from the company Horiba and the other from Malvern Panalytical.

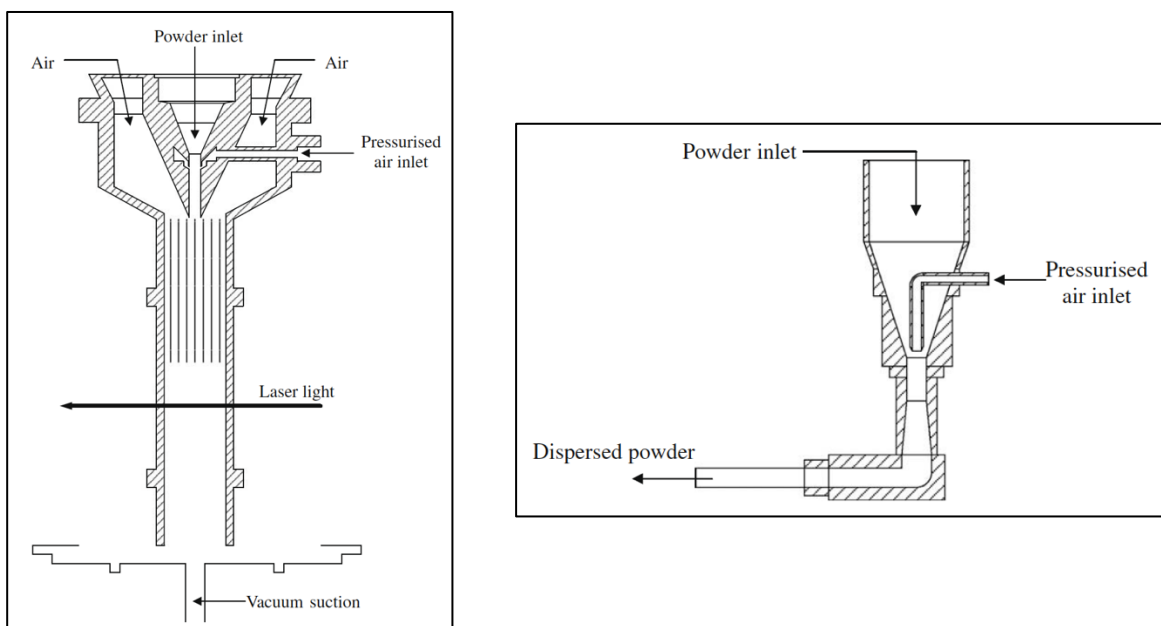

Figure 6-4: Left: The Horiba powder jet II. Right: The Malvern Scirocco dry powder dispersion device. [70] [71]

In Table 3-1, three air dispersion nozzles were presented. These are specially designed nozzles using different fundamental principles to disperse particles using compressed air. The method of using pressurized air is a very common way of dispersing particle powder (Figure 6-4). Pressurized air is readily available at the faculty workshop, and is therefore a method that is going to be further looked into when the possible dispersion devices are presented below.



### 6.2.1 POINT SANDBLASTER

A Point sandblaster from Biltema was available at the workshop. The sandblasters main objective is to disperse sand grains onto a surface at a high velocity. Dispersing bulk powder particles would be a very similar task, making it a viable option. From 2008 study, “Simple and cost-effective powder disperser for aerosol particle size measurement” [31], the possible use of a sandblaster was further established. The study found that a simple inexpensive vacuum ejector could produce the same dispersion results as expensive commercial dry powder dispersers. A sandblaster is a vacuum ejector used to disperse sand (Figure 6-5), by creating a vacuum the particles are sucked up into the high velocity air flow. The sandblaster has a nozzle that was measured to a diameter of 2,5 mm (Figure 6-5), whereas the optimal diameter found in the study was 1,0 mm at a 90 psi pressure (nozzles over 1.0 mm were not tested).



*Figure 6-5: A picture of the Biltema point sandblaster and a picture of the nozzle inside the sandblaster.*

Further the ejector nozzle from Table 3-1, is nearly identical to the layout of the sandblaster (Figure 6-6). The ejector nozzle like the sandblaster has two feed inlets, where one provides pressurized air and the other the powder. Transporting the powder from the canister is done either by gravity or pressure different/vacuum between the pressurized air inlet and the powder inlet, pushing the powder towards the dispersion area. The dispersion of the powder happens when the powder is hit by the air traveling at a high velocity. The particles get rapidly accelerated putting a force on the particle clusters higher than the interparticle forces, breaking them apart (Figure 6-6). Collisions between particles and particles and walls will also contribute to the dispersion process. Ejector nozzles ability to disperse particle powder has been investigate in a number of studies. The results showing a high success rate dispersing cohesive particle clusters into primary particles. [24]

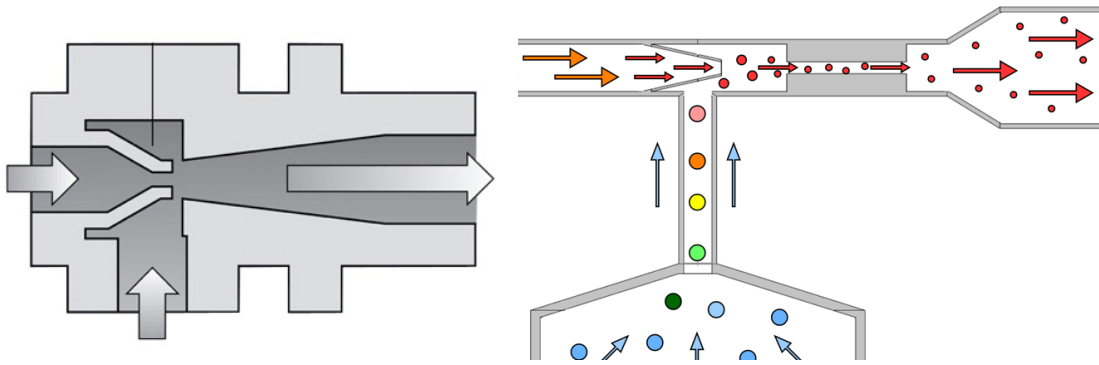

Figure 6-6: An illustration of how a vacuum generator works [72], and an illustration of how the sandblaster disperses particle powder.

### 6.2.2 PAINT GUN

In addition to the sandblaster, a paint gun was available for use at the workshop. It is an Asturo TIPO E70 – Low pressure spray gun, older model. Its main objective is to disperse paint on to a surface. Changing the paint with bulk powder particles instead should give similar results, as the particles should also fluidize when it comes in contact with the high velocity air. The paint gun uses an atomizer nozzle with a diameter of 1.8 mm to disperse the particles (Figure 6-7), it uses the same principles as the sandblaster with pressurized air to disperse, but with a different type of nozzle.



Figure 6-7: The paint gun.

In Figure 6-8 an illustration of how the paint gun works can be seen, it is quite different from the educator nozzle. Same as the fluid in the figure, the particles fall down from the canister being transported down through the centre of the nozzle where its met by high velocity air on all sides, as well as from two nozzles further out. This inflicts the particles with a rapid acceleration and deceleration. The air puts a large force on the particle, hopefully making the aggregate and agglomerate particle cluster break up into primary particles. [73]

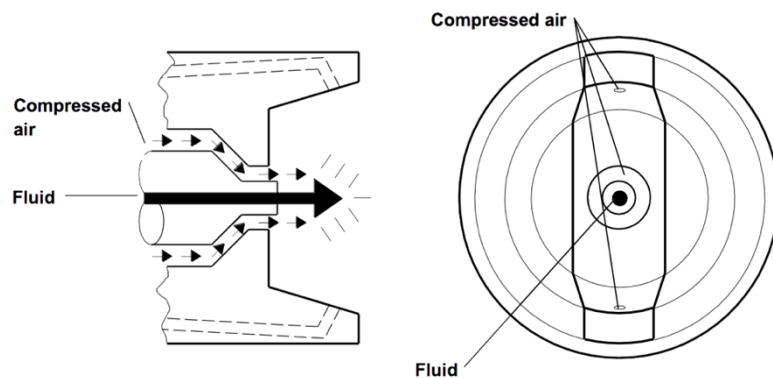

Figure 6-8: A picture of the paint gun nozzle and an illustration of how the paint atomizes a fluid or in this case particle powder. [73]

## 7 PARTICLE REVIEW & SELECTION

---

*This chapter aims to give the reader an understanding of the bulk powder particle market and possible particle sources that can be used for sensor testing. Further putting forth the particles that will be bought and included in the testing.*

**Main objective:** Identify suitable particle matter for testing. With a size under PM2.5.

### REQUIREMENTS

There are certain requirements that need to be taken into account when choosing the particles.

- Particle size between 2.5  $\mu\text{m}$  and 0.5  $\mu\text{m}$ .
- No hazardous material.
- Particles should be non-conductive.
- As uniformly sized and spherical as possible.
- Must be within the budget of the project.

### 7.1 UNIFORM PARTICLE SELECTION

There are three options getting uniformly sized particles, finding a suitable source, finding a company who sells micro/nano particles, or making the particles needed. Making micro/nano particles is very expensive, demand high accurate machinery, laboratory equipment and a large knowledge base, making it a nonviable option. Finding a source that gives out just one specific particle size is nearly impossible. Any natural or artificial sources like car emission, other combustion, dust etc. releases a mixture of different particle sizes. Using a source will therefore be done if a size distribution is needed. One inexpensive particle powder which consist of a relatively uniform size distribution is corn starch, the only problem is it easily absorbs water making the particles bigger. When it comes to buying particles the problems are finding the right product and from there finding a quality manufacturer to insure getting the product that is need with the right quality.

It is important to keep in mind that a large amount of particles conduct electricity. This is vital avoid as it can short-circuit all electrical components on the test-rig. It is therefore necessary to take appropriate measures to prevent this from happening, by either testing non-conductive materials and/or protecting all electronic equipment. The ladder giving greater testing opportunity, but makes the test-rig more complicated to build, maintain etc. It is therefore favourable to choose non-conducting materials.

**BANGS LABORATORY, INC.**

Ordering specific particles with a specific size and given quality specifications is a very controlled and safe way to get exactly the correct particles. The problem with this is that the prices are high, and finding a supplier with a price that is within the budget limits is a challenge. The price increases drastically with how spherical the shape of the particles are. This is problematic when there are certain budgetary limitations. Here are some price examples from Bangs Laboratory, Inc:

*Table 7-1: Overview of different particles from Bangs Laboratory, Inc. and their respective prices.*

Material	Polymer	Polymer	Silica	Silica
Amount	1 gram	1 gram	1 gram	1 gram
Size	1.0 $\mu\text{m}$	2.0 $\mu\text{m}$	1.0 $\mu\text{m}$	2.0 $\mu\text{m}$
Spherical	Yes	Yes	Yes	Yes
Price	249 \$	709 \$	309 \$	360 \$

As seen from Table 7-1 for just 1 gram of these particles the price is up over 2000 NOK, which makes it difficult to purchase.

**NANOGRAPHI**

The company Nanografi delivers a wide range of particles within the micro and nano particle segment. After several email exchanges with a representative from Nanografi, where the different requirements were put forth. A quotation was received with several particle types and sizes, where the price point was more manageable. Most of them were non-viable as they either were carbon nanotubes or graphene nanoplatelets, where both have very high aspect ratios, as well as the graphene being particularly conductive. After this first selection there were only 2 particle types left, Nanoclay and nanocalcite. The nanoclay (Figure 7-1) was ruled out because of uncertainty of behaviour in contact with water. The nanocalcite was the only one left, which was viable to use. Therefore were these particles bought in (Table 7-2).

*Table 7-2: Specifications for the nano calcite powder. [74] [75]*

Nano calcite powder	
Size	0.9 $\mu\text{m}$ (900 nm)
Quality	99.9%
Spherical	Has a crystal structure, is fairly spherical (see Figure 7-1)
Amount	100 g, 500g
Price	23 € (252 NOK), 82 € (900 NOK)
Comment	Does not lead electricity, non-hazardous, non-flammable

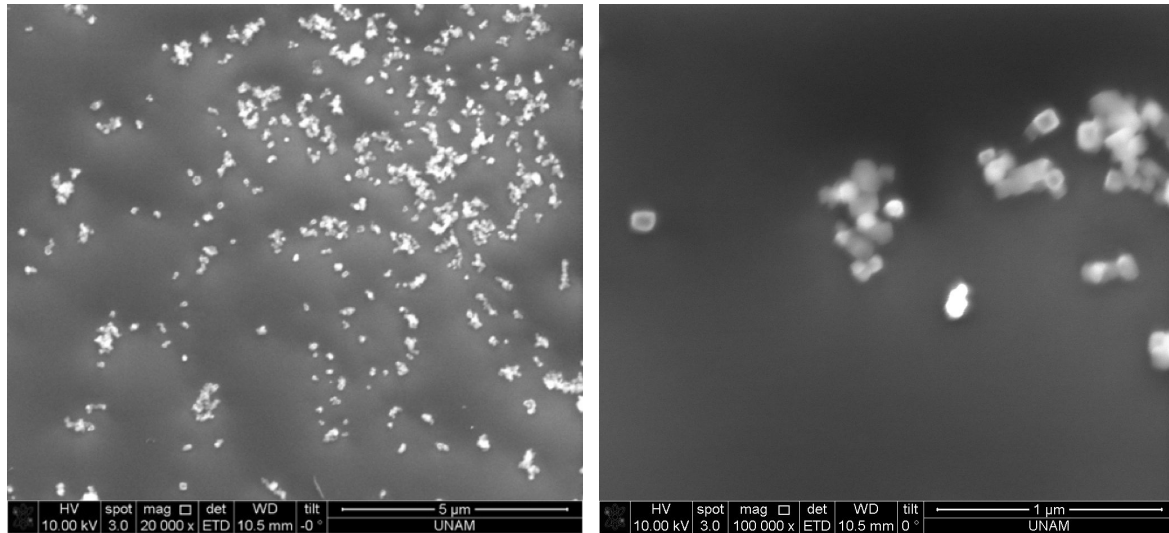

Figure 7-1: Pictures taken through a microscope of the nano calcite. At 20.000x and 100.000x magnification. Curtesy of Nanografi. [74]

## 7.2 POSSIBLE INEXPENSIVE PARTICLES

Being able to use inexpensive particles to test the sensor and to do preliminary testing, without having to use the expensive particles purchased, is an advantage. Therefore different particle sources and low-cost bulk powder particles are review here.

### CORN STARCH

Starch is a very accessible and inexpensive bulk powder which can be uses in preliminary testing (Table 7-3). It is not a suitable powder to using in calibration testing of the sensor as stated before, but can be used to test out possible dispersion devices, to evaluate their dispersion efficiency.

Table 7-3: Specifications for corn starch powder.

Corn starch	
Size	0.1-0.8 µm (Depending on the supplier) [76]
Spherical	-
Amount	400 g
Price	24 NOK
Comment	Does not lead electricity, changes size in contact with water, flammable

### PLASTIC PARTICLES FROM 3D-PRINTING

The emissions from a 3D-printer is a growing problem and a new field of research. When using a 3D-printer it releases a particle cloud of ultra-fine plastic particles [11]. Research presented in a technical note, “Ultrafine particle emissions from desktop 3D printers” [11], concluded that particle size distribution emitted from 3D-printers to be between 11.5 nm – 116 nm. Other

studies have also concluded that 3D-printers emit mainly within the ultra-fine particle size range, but has also registered a size distribution up to 31  $\mu\text{m}$  but in a very small quantity [77] [78]. Size range can vary depending on the feedstock material and type of printer. Seeing that Oak Lab has several 3D-printers, it could be useful to test the particle emission from them, testing the lower boundaries of the sensor.

### WAX CANDLES

One of the most inexpensive fine/ultra-fine particle sources must be burning of wax candles. When burning wax candles, they have a particle distribution ranging from 10-500nm [79], depending on what the candle is made of. When lighting wax candles indoors, they can stand for a large amount of particles contaminating the air, making a bad indoor climate [79] [80]. By burning the same candles that have been used in research earlier, the particle size distribution from other research can be compared to the measured particle distribution from the CMUT sensor. This is an inexpensive and simple way to get an indication of whether the sensor monitors correctly or not.

## 7.3 TECHNICAL SUMMARY

The particles that is going to be used for testing in this project are the calcite particles bought from Nanografi (Figure 7-2), as well as the corn starch. The corn starch is only going to be used in preliminary testing, to investigate the efficiency of the different dispersion devices. The calcite is a highly accurate particle powder which is going to be used for future calibrations. More high accuracy powder should be bought in other sizes for more testing. For particle size distribution, sources like wax candles, 3D-printers etc. can be used, together with data gathered from previously performed testing.



*Figure 7-2: The Calcite container from Nanografi.*

**Other particle manufacturers:** Inframat, Abcr, advanced materials US and more.

## 8 FLOW SIMULATION: DESIGN & DISTRIBUTION ANALYSIS

*In this chapter a flow simulation analysis will be done, to find the solution that produces the most uniform distribution through the system. This will be accomplished by doing a simulation of relevant parts and solutions, arriving through testing at the most ideal one.*

Using a computational fluid dynamics program like Solidworks a detailed flow image of the test-rig can be visualized. Being able to try out several different setups including build shape, air speed, flow type, flow direction etc. makes the development process simpler and a final design can be accomplish faster. In Figure 8-1 and Table 8-1, the overview of the test-rig assembly which is going to be used for flow simulation can be seen. Not all parts that will be included in the full rig are incorporated into the flow simulation rig, as they serve no purpose there. This makes the assembly simpler and the simulations faster. The fan marks the start and end of the loop. Further a distribution solution is need to get a uniform flow of particles through the sensor area. The dimensions of rig is chosen on the basis of the selection done in the previous chapter. Only setup 3 will be simulated as the results from it can be used for the other setups.

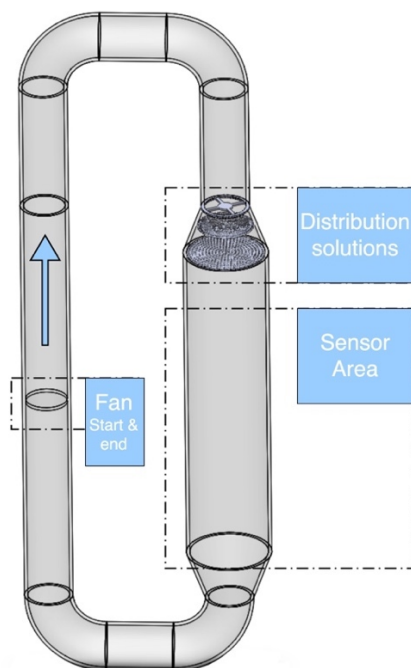

*Table 8-1: Main dimensions of the test-rig.*

Dimensions	
Height	2300 mm
Width	125/ 235 mm
Length sensor area	1350 mm
Funnels length	150 mm

*Figure 8-1: Overview of the test-rig assembly used for flow simulation. This is setup 3 (Figure 5-6) from the previous chapter. CAD drawing made in Solidworks*

The rig setup has a straight pipe before the distribution solution. Because through simulation it was found that when particles take on a 90 degree turn they will bounce back from the opposing wall and need time to settle. This is a minor problem but makes the distribution quality better.

## 8.1 PARTICLE DISTRIBUTION SOLUTION

Several different solutions have been tested through simulation to arrive at a final one that distributes the particles in a sufficient manner, producing a uniform particle distribution with an even velocity past the sensor area. This process is presented below.

### SIMULATION GOALS

- The distributor must distribute the particles uniformly through the sensor area pipe.
- The particles need to flow in a near uniform speed past the sensor area.
- The distributor should be able to compensate for the rotating air caused by the fan, making a linear flow. This to avoid centripetal acceleration on the particles.
- The distribution solution must be designed in such a way that a 3D-printer is able to produce it.

### 8.1.1 SIMULATION PARAMETERS

In order to get as accurate results as possible on the CFD analysis the setup of the simulation need to be done correctly. All essential settings are listed below in Table 8-2 and Table 8-3, both for initial simulation settings and more specifically for the particle study. The same settings are used for all simulation to get comparable results. All simulation figures shown in this chapter uses the velocity range shown in Figure 8-2. The fan chosen is not the one that is going to be used. It was chosen as it has enough similarities to the actual one. The pre-defined air speed from the fan is 2,8 m/s which is much higher than the speed which is going to be used during the testing. This is ideal, making the simulation an extreme scenario. For mesh cut plot see appendix L.

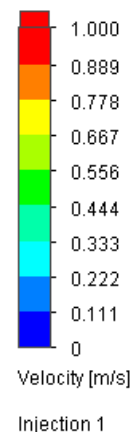

Figure 8-2:  
Simulation velocity  
range.

Table 8-2: The initial simulation settings,.

Initial specifications	
Type of study	<i>Internal</i>
Physical features	<i>Gravity</i>
Gases/fluids	<i>Air</i>
Flow type	<i>Laminar &amp; Turbulent</i>
Unit system	<i>SI</i>
Temperature	<i>101325 Pa</i>
Pressure	<i>293.2 K</i>
Computational domain	<i>Auto assigned</i>
Global Mesh	<i>5 (high quality)</i>
Local mesh	<i>Extra refinement around distribution area, level 5.</i>



Table 8-2 continued: The initial simulation settings,.

Initial specifications	
Fan setup	Internal, Predefined Type: Comair Rotron, DC, MCxxF3, Low speed
Face fluid exits the fan	Front face of fan plate
Face fluid enters the fan	Back face of fan plate
Air speed from fan	2.8 m/s

Table 8-3: The particle study settings.

Particle study	
Starting point	Front face of fan plate
Surface interaction	Ideal reflection
Number of particle paths	150
Particle size	1 Micron
Particles material	Calcite
Particle density	2.71 g/cm <sup>3</sup>

### 8.1.2 SOLUTION 1: THREE PART SOLUTION

This is a configuration of several solutions, these were thought to be favourable designs in order to distribute the particles. These parts have been tested in different sizes, curves etc. in order to get the best results out of them. Solution 1 are three separate parts (Figure 8-3) assembled in the funnel leading into the sensor area. These were tested both individually and all together to see how good they could distribute the particles. The layout of these parts were the ones that had the best distribution of the different adjustments that was done through simulation. All of them are 5mm thick, remaining dimensions in Table 8-4.

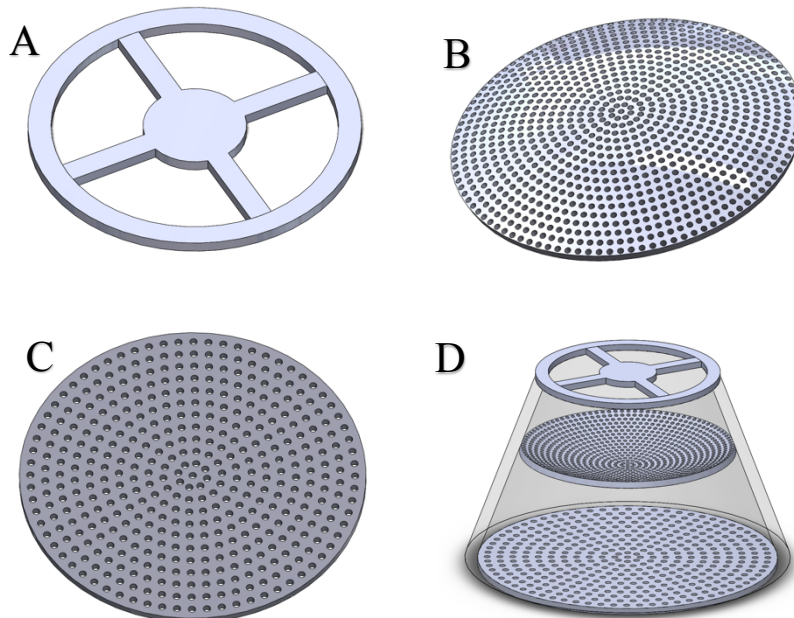

Table 8-4: Dimensions for solution 1 parts.

Diffuser	Diameter
1	125mm (Inner)
2	235 mm
3	170 mm
All	125/235 mm
Diffuser	Hole dim.
2	5mm
3	3 mm

Figure 8-3: Illustrations of the three parts in solution 1 and the whole assembly: A: Diffuser 1, B: Diffuser 2, C: Diffuser 3, D: All parts in one assembly. CAD drawings made in Solidworks

## PARTICLE SIMULATION

In Figure 8-4 the flow simulations for the three parts in solution 1 is shown, as well as all the parts in one assembly. Cases A, B and D shows clearly that the rotation motion of the air has not be corrected. It is the same for case C but it is not as clear in the picture. Studying the flow simulation, it can be seen that they do not give an optimal particle distribution either. (Figure 8-4)

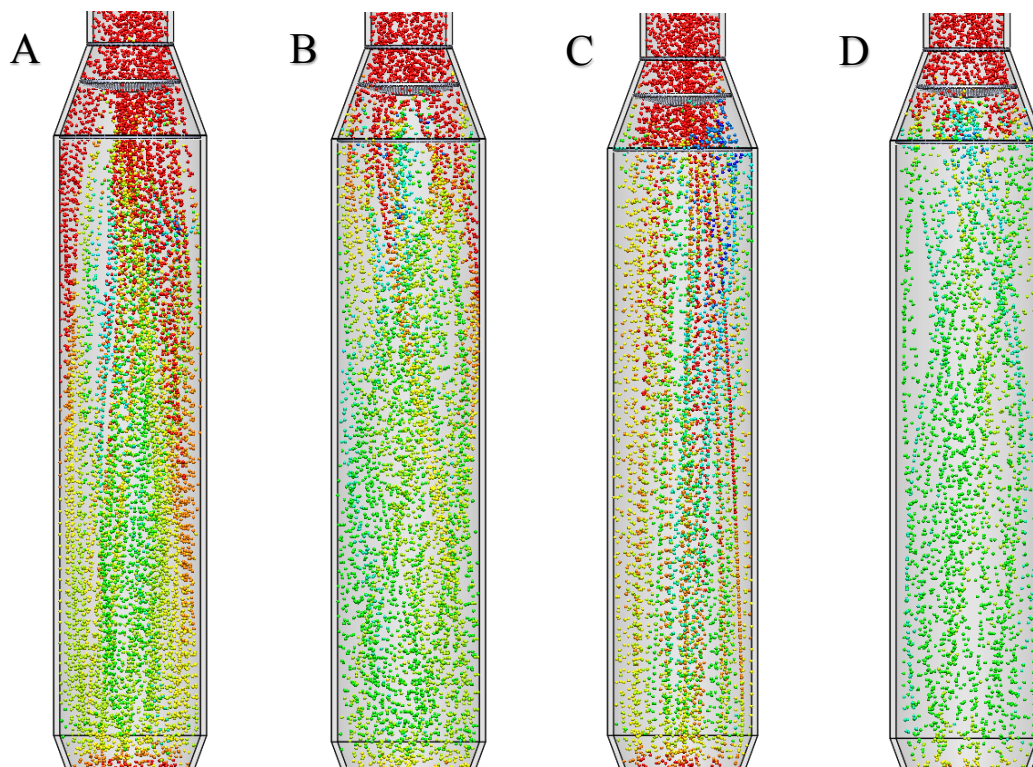

*Figure 8-4: Particle simulation of solution 1, A: Diffuser 1, B: Diffuser 2, C: Diffuser 3 D: All. Flow simulation done in Solidworks.*

### 8.1.3 SOLUTION 2 & 3: ONE PART SOLUTION

Solution 2 & 3 were designed based on the results gathered after the particle studies conducted on solution 1. They consist of only one part making it a simpler design, even though they might have a higher complexity. They can both be printed as one part and is easier to handle when using the test-rig. It has the same funnel shape as the rig funnel. See Table 8-5 for dimensions.

#### SIMULATION PART: SOLUTION 2

One of the problems with solution 1, was that it could not stop the rotational motion of the air. Making small and angled square funnels, stopped the rotation and forced the air to move linear (Figure 8-5). It has the same dimension as solution 3.

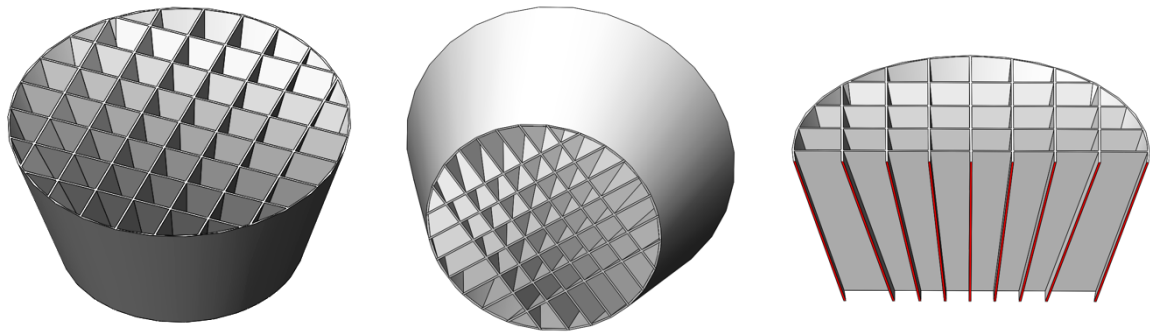

Figure 8-5: Three illustrations to understand the workings of solution 2. CAD drawings made in Solidworks

**SIMULATION PART: SOLUTION 3**

After getting the wanted results from solution 2, several flow simulations were carried out trying to optimize the solution. From this came solution 3. Instead of square funnels, round funnels was made to better utilize the shape of the test pipe. The angle of the side wall are the same as for the funnel. The solution and dimensions are shown in Figure 8-6 and Table 8-5.

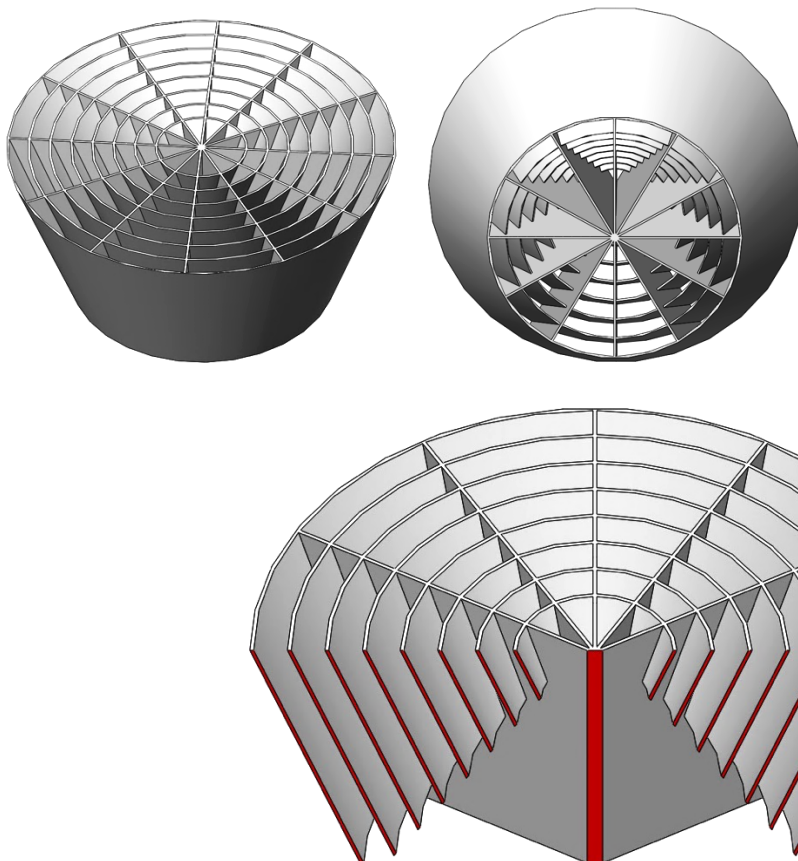

Table 8-5: Dimensions for solution 3.

Dimensions	
Bottom dim	125 mm
Height	80 mm
Angle	110,14°

Figure 8-6: Overview of solution 3 showing the design. CAD drawings made in Solidworks

## PARTICLE SIMULATION

It is not easy to see that the rotational movement of the air cause by the fan has stop after the distribution device. Cutting the air in six directions over 80mm makes the air go down in a linear motion. Both simulation 2 & 3 gives quite good distributions, but solution 3 is a little better (Figure 8-7). It can be seen from the colouring of the particles that for all solution it takes some to get the most uniformly particle speed. To show how the particles would move if no distribution parts was put in, see Figure 8-7, C.

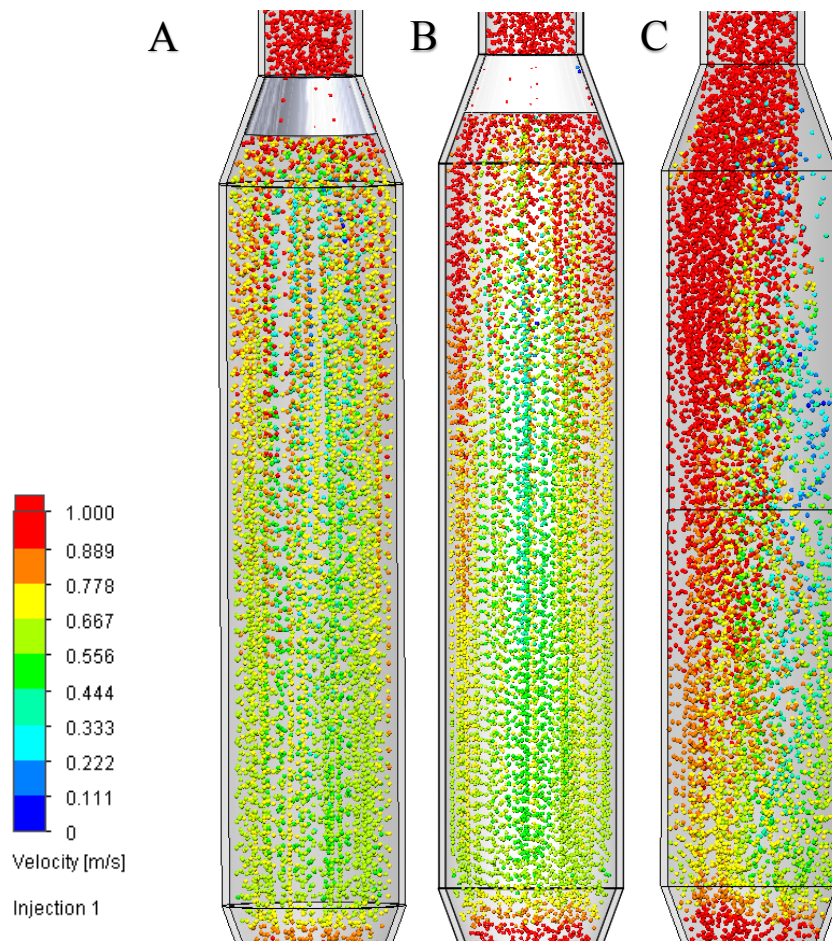

Figure 8-7: Particle simulation of solution 2 & 3, and a particle simulation without a distribution device. A: Solution 2, B: Solution 3, C: Nothing. Flow simulation done in Solidworks.

### SOLUTION 1 PROBLEM, SOLVED WITH SOLUTION 2 & 3

The most important problem with the solution 1 parts, was that they could not compensate for the rotational motion of the air caused by the fan (Figure 8-8). The centripetal acceleration that this motion makes, may cause a higher particle concentration around the edge of the testing pipe than in the middle. This will then result in a uneven distribution. Solution 2 & 3 fixes this problem, making the air and particles go in straight lines down the testing pipe (Figure 8-8).

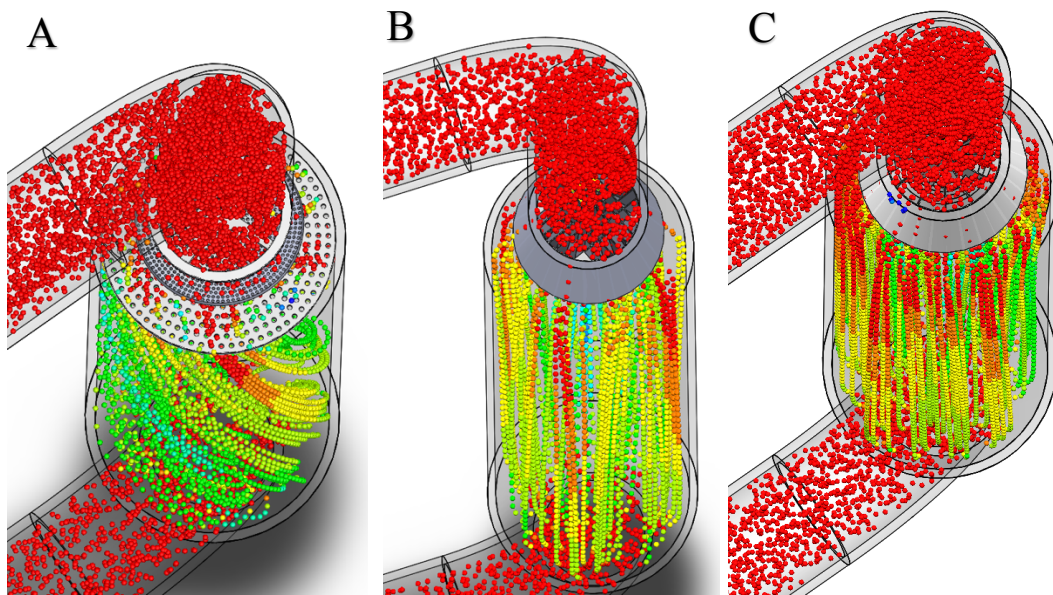

Figure 8-8: A: Rotational motion for solution 1, B: Linear flow, solution 2, C: Linear flow, solution 3. Flow simulation done in Solidworks.

#### 8.1.4 OTHER SOLUTIONS

There were several other solutions tested, here are some of them. These were either too complicated and/or did not perform the task good enough (Figure 8-9).

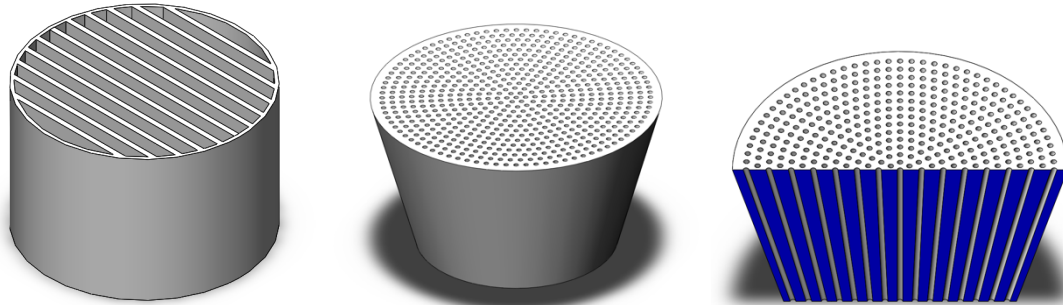

Figure 8-9: Different distribution solutions tested, that were not good enough. CAD drawings made in Solidworks

#### 8.1.5 STATISTICAL ANALYSIS OF PARTICLE TRAVEL TIME

To see if there is a connection between distribution quality and uniformity of particle speeds through the system, a statistics analysis has been conducted. Travel time data was collected from Solidworks and used to statistically calculate the variation of travel time for the different particle paths (Table 8-6). Travel time data, means the time the different particle paths take through the system. From these calculations the solution with the most uniform speed was arrived at. The time will and do not need to match completely as the path length of the particles will deviate slightly depending on where they go through the pipes etc.

The dataset had some error values for particles that did not find the path to the end of the loop called “maximum steps in cell”. These numbers were not included in the calculations as they would only make the results less accurate. The formulas used to calculate the coefficient of variation for each solution is presented underneath:

$$Average = A = \frac{Sum\ of\ data\ in\ dataset}{N\ (Number\ of\ data\ points)} \tag{6.1}$$

$$Standard\ deviation = SD = \sqrt{\frac{\sum|x - A|^2}{N - 1}} \tag{6.2}$$

$$Coefficient\ of\ variation = \frac{SD}{A} \tag{6.3}$$

Table 8-6: Comparing the variation in travel time between the different solutions.

Variation in travel time for different particle paths							
Calculations	Solution 3	Solution 2	All	DIF1	DIF2	DIF3	Nothing
Average	3.546	3.660	4.574	3.509	4.174	3.900	3.407
Standard deviation	0.385	0.460	0.738	0.509	0.734	1.278	0.921
Coefficient of variation	0.118	0.126	0.159	0.145	0.176	0.328	0.270
Percent variation	10.8%	12.6%	15.9%	14.5%	17.6%	32.8%	27%

From Table 8-6, the results show that it is solution 3 that has the most uniform travel time with a variation of 10,8%. To further illustrated the difference in variation, a scatter plot of the best and worst solution has been made (Figure 8-10). It clear that diffuser 3 has several particle paths that take twice as long to finish the loop. This is indicates that there might be some kind of backdraft or obstacles in the system, holding on to some of the particles, which is not ideal. See appendix M-P for complete data set.

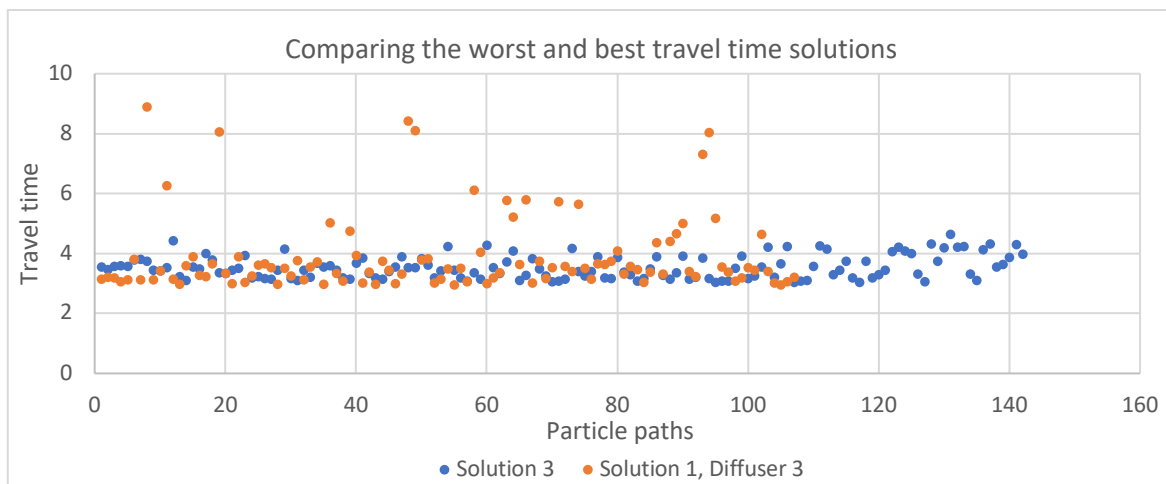

Figure 8-10: Comparison of the worst and best distribution solution in travel time by a scatter plot.

## 8.2 FLOW DIRECTION ANALYSIS

Through the flow simulations for the distribution solution a downward flow past the sensor area has been used, but this is not necessarily the best solution. The flow of the particles can pass the sensor area both downwards and upwards (Figure 8-11). The downwards flow can be preferable as it uses the gravity to its advantage, but to be sure a flow simulation was conducted, using solution 3 as distribution device. By comparing the travel time variation for solution 3 in Table 8-7 with the travel time variation collected from the upwards flow simulation the best flow direction could be determined.

*Table 8-7: Comparing particle travel time between downwards and upwards flow direction.*

Calculations	Downwards	Upwards
Average	3.546	3.541
Standard deviation	0.385	0.432
Coefficient of variation	0.118	0.122
Percent variation	10.8%	12.2%

As predicted the downwards flow gave the best results. This can indicate that with an upwards flow some particle backdraft because of gravity. It will therefore be proceeded with the downwards flow in the development.

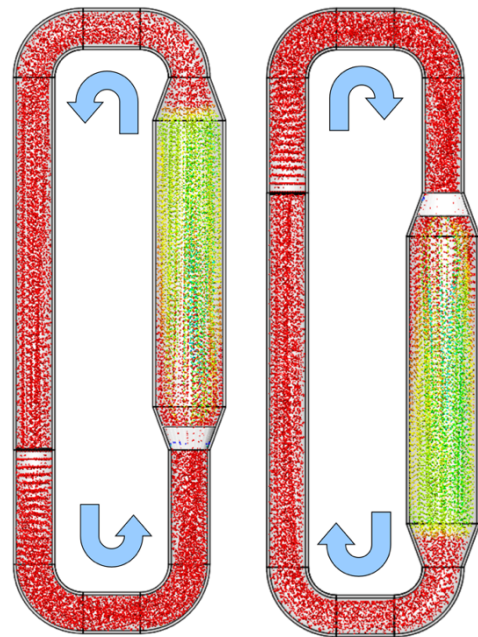

*Figure 8-11: Showing test-rig assembly for both the downwards and upwards flow simulation. Flow simulation done in Solidworks.*

## 8.3 SIMULATION SUMMARY

The flow simulations conducted on solutions 1, 2, 3 and others, gave back results that concluded that it was solution 3 that had the best distribution and the most uniform particle flow. Table 8-6 showed that it is solution 3 that had the least travel time variation at 10.8%. Furthermore the flow direction analysis concluded that it was the downwards flow path that gave the best results. The length of the sensor area pipe is chosen to be that long, within the length limitations because it gives the particles time to settle, making it possible for better monitoring by the sensor.





## 9 FINAL ASSEMBLY OF TEST-RIG

*This chapter will present the final test-rig assembly produced through this project, showing the whole test-rig with the developed parts. Further giving a walk-through of the remaining parts, why they are needed and how they are assembled. Ending with a presentation of the rig in its test room and a total cost and dispersion cost comparison.*

### 9.1 COMPLETE ASSEMBLY

Together with the parts mention below, a full assembly of the test-rig has be made (Figure 9-1 and Figure 9-2). Here all the selected and design parts are shown together forming setup 3, 2 and 1. Setup 1 and 2 consist of parts from setup 3, as it was stated to be in the test-rig specifications. Final rig dimensions and exploded view for setup 3, can be seen in appendix A & B.

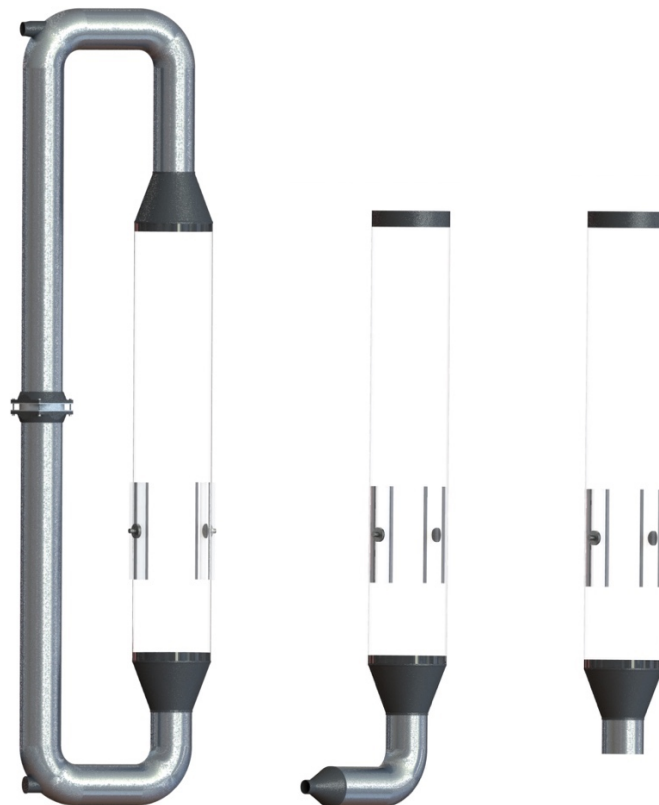

*Figure 9-1: Rendering of the full test-rig assembly, with a simple illustration of the sensor. As well as renderings of two possible Start-End rigs (Setup 1 & 2). Black part on top illustrates a filter. CAD renderings made in Solidworks.*

On setup 3, the dispersion opening is mounted in the top left corner and the outlet is mounted in the bottom left. This is to disperse the particles through the largest area first to get a better distribution through the system. On setup 2 the dispersion opening is the start of the particle

flow, with an opening which fits the 40 mm sandblaster and the paint gun. Setup 1 can be adjusted to fit the potential source that is wanted to test against.



*Figure 9-2: Assembly rendering from below showing the distribution device mounted in the funnel.  
CAD rendering made in Solidworks.*

## 9.2 REMAINING KEY COMPONENTS

To assemble a complete rig a few parts needed to be made. The transport and sensor area pipes, bends and distribution device are selected, and the remaining parts have been design and are listed below.

### FUNNEL

Because the dimension of the transport pipe and sensor pipe is not the same, a funnel is needed to connect them together (Figure 9-3). It is designed using the same principles as the fan holder. The transport pipe will be slid onto the smaller circle and the sensor pipe will be slid on the larger circle. The selected dispersion device solution 3, has the same angle as the funnel to fit.

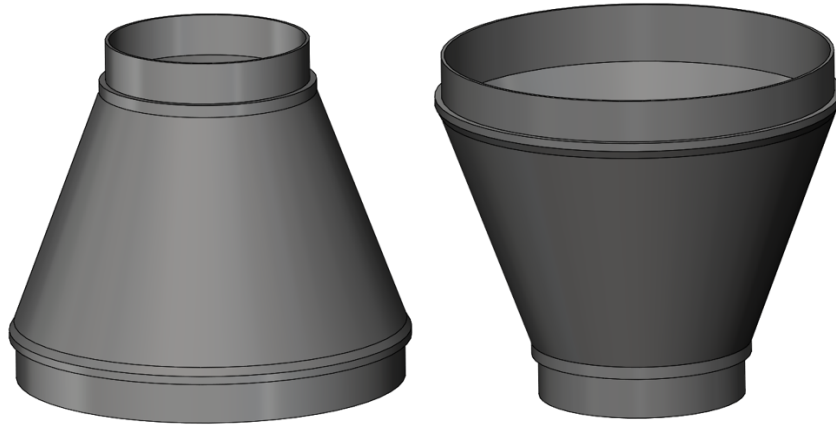

*Figure 9-3: The funnel connecting the transport pipe to the sensor area pipe. CAD drawings made in Solidworks.*

#### **DISPERSION OPENINGS AND LIDS FOR LOOPED SETUP**

In order to get the dispersed particles into the looped setup two openings were needed. One opening for dispersing the particles into the rig, and one to release excess air produced by the pressurized air from the sandblaster. The surface around the pipes are design to follow the curvature of the pipe bend (Figure 9-4). The largest outer pipe diameter is 50 mm, on both of them. The inner diameter on the inlet (A) is 40 mm, which fits the sandblaster perfectly and also fitting the paint gun (which is a little smaller).

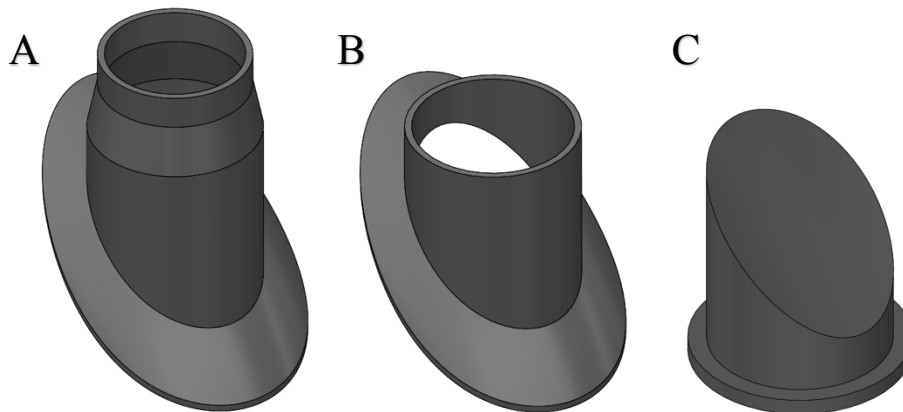
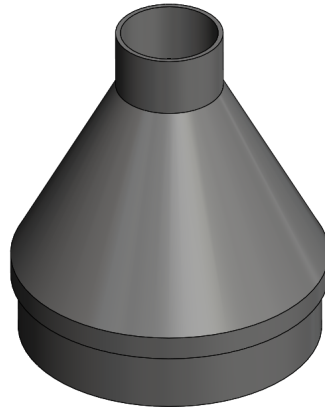

*Figure 9-4: Inlet, outlet and lid for outlet, for the looped setup. A: Inlet, B: outlet, C: Outlet lid. CAD drawings made in Solidworks.*

When the dispersed particles have entered the test-rig a lid must be put on the air outlet in order to close the rig off (Figure 9-4). The particle inlet will be sealed off by the nozzle of the sandblaster. These openings are placed on the bends of the system. This is done to ensure ways of customization, making it possible to disperse the particles from four different spots on the rig.

### DISPERSION OPENING FORCED CONVECTION SETUP

To close of the forced setup inlet a part similar to the funnel and looped setup opening is created (Figure 9-5). The smallest opening is 40 mm. The larger side has a diameter of 124 mm which can be slid into the ventilation piping. This will not be made for this project, but to show a possible part that can be made if needed.



*Figure 9-5: Dispersion opening for force convection setup (setup 2). CAD drawing made in Solidworks.*

#### 9.2.1 FINAL PARTS

After completing the full test-rig assembly, it can be produces and built. Several of the parts have been chosen because of availability at the RealTek workshop, the rest have been 3D-printed or bought. The transportation and sensor area pipes were available at the workshop. The bend, pipe clamp and tape were bought in form Ski Bygg Ås (Figure 9-6 and Figure 9-7). The pipes where cut to measure using a hacksaw.

#### AVAILABLE PARTS



*Figure 9-6: The aluminium ventilation pipe (Transport) and the clear polycarbonate pipe (Sensor area) [81].*

### PURCHASED PARTS

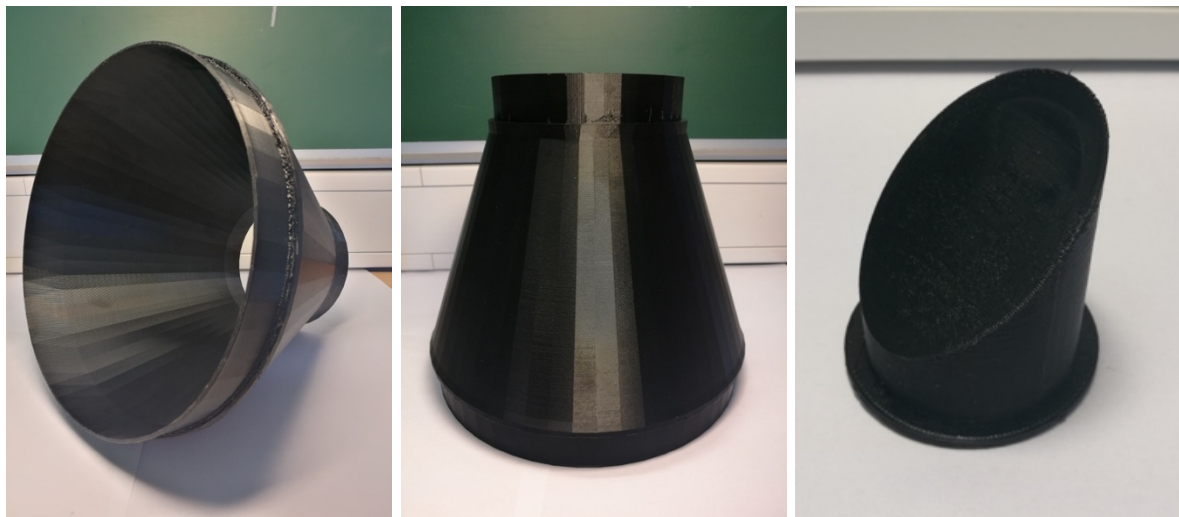

*Figure 9-7: Pictures of the bend, pipe clamp and tape bought at Ski Bygg Ås [81].*

### 3D-PRINTED PARTS

The funnels, fan holders, fan plate, distribution device, dispersion openings for setup 3 and lid were all 3D-printed at the Oak Lab. Some are shown (Figure 9-8) here and others as part of partial assemblies in the next chapter.

### FUNNEL & LID



*Figure 9-8: The funnel shown from two different angles and the lid for the dispersion opening outlet.*

## 9.3 PARTIAL ASSEMBLIES

Several partial assemblies need to be put together before assembling the whole test-rig. These assemblies are shown below.

### DISPERSION OPENINGS ASSEMBLY

It was made holes in two of the bends to mount the dispersion openings made. The holes were cut using a 51 mm hole saw, giving the openings a 1 mm clearance. The holes were cut so they would be centred with the pipe and facing the same direction. To ensure that this was accomplished the bend was fasted with a jig and sawed using a drill press. The dispersion

openings were slid through the sawed hole and fasted using super glue. To seal of any inaccuracies, a clear silicone sealant was used around the edges on the in- and outside of the openings (Figure 9-9)



*Figure 9-9: Pictures of the dispersion openings mounted to a bend, showing the sealant on the in- and outside. Further giving a view with the lid placed in the opening.*

#### **FAN ASSEMBLY**

The four parts making the fan assembly needed to be fasted together (Figure 9-10). Two fan holder, one fan plate and the fan. The fan had M3 holes on each side, therefore both the fan holders and fan plate was 3D-printed with the same. But because of a little short-sightedness these holes needed to be widened, as long enough M3 screw could not be found at the workshop. 55 mm M5 screw with bolts was available and the holes were therefore adjusted with a drill to fit these. To seal of any openings and still be able to take the assembly apart, tape is used.



*Figure 9-10: Pictures of the fan rig showing how it is fasted and seal, as well as a view through the assembly.*

### **DISTRIBUTION DEVICE ASSEMBLY**

As the distribution device has the same wall angle as the funnel it can just be slid into place. It can be seen in Figure 9-11, that it fit seamlessly. The device is fastened to the funnel using two small screws, one on each side (Figure 9-11).



*Figure 9-11: The distribution device fastened to the funnel. The white parts are powder from testing.*

## **9.4 COMPLETION- & REPETITIVE PROCEDURES**

Before the rig is ready for testing certain smaller procedures need to be done. Further some repetitive procedures need to be executed in-between testing of the rig.

### **FITTING OF SENSOR**

For sensors to be tested on the system some alteration to the test-rig is needed. For the CMUT sensor to fit, parts of the sensor area pipe need to be cut out. These cut outs should therefore be used to fit other possible sensors for testing. Using the same type of plate to mount them. This will need to be developed and produced as seen fit.

### **SEALING THE TEST-RIG AIRTIGHT**

To guarantee that the test-rig is airtight, gasket, tape or sealant need to be used, on the parts that have not already been sealed. As previously stated, it is important to hold on to the requirement about interchangeability. The bends have gaskets on both side on the connection part. The rest of the transitions on the assembly will be sealed of using ventilation tape.

### CLEANING OF THE RIG

In-between tests the rig needs to be cleaned. This can be done using the same pressurized air as for the sandblaster, just using a different plug-in. Blowing away any residual particles. The ultra-fine particles can stick to the surface in such a way that the air will not be enough. In such a case, cleaning with water will be needed. This can be done using a garden hose or a pressure washer. An example of the need for cleaning can be seen in Figure 9-11.

## 9.5 TEST-RIG

Now that all components are developed and ready, the test-rig has been put together (Figure 9-12). It consist of aluminium pipes and bends, a clear polycarbonate pipe (sensor area), and the remaining parts previously presented. Ventilation tape has been used to seal the test-rig.



*Figure 9-12: Overview of the test-rig assembly.*

A room was built inside the Oak Lab, to accommodate the test-rig. The room will have its own ventilation, so the particles can be transported out immediately after use. It has clear 3 mm polycarbonate plates as walls to makes it more open. To seal the corners around the plates, a



fitted rubber band was pressed in place around the plate. In Figure 9-13, the rig can be seen inside the space it is going to be when used for testing. Two simple wooden cut outs has been made and fasted to the floor for the rig to sit in. The floor and ceiling is made of plywood. The rig is too high for the room so some holes will be cut through the plywood, to adapt to the rig. Some ventilation and sawing works is still needed for the room to be complete.



*Figure 9-13: The test-rig inside the room/space it is going to be when used for testing.*

## 9.6 TOTAL TEST-RIG COST & DISPERSION COST COMPARISON

The preliminary total cost of the test-rig is presented in Table 9-1. Prices with parentheses have been found online (date: 5<sup>th</sup> of may), as the parts have been available at the workshop or Oak Lab. Estimations have been done for 3D-printing, setting 1 gram of print at 0.25 NOK. The poly carbonate pipe price is a conservative estimate as a price for the pipe gotten at the Oak Lab was not found.

*Table 9-1: Test-rig part list with prices and total cost.*

Part	Amount	Weight [g]	Unit price [NOK]	Total price [NOK]
Clear polycarbonate pipe	1	-	-	5000,-
Ventilation pipes	3	-	115,- (1.15 m)	(345,-)
Bends	4	-	207,-	(828,-)
Fan	1	-	99,-	(99,-)
Fan holders	2	89*2	0.25 NOK pr. gram	44.5,-
Fan plate	1	35	0.25 NOK pr. gram	8.75,-
Funnels	2	280*2	0.25 NOK pr. gram	140,-
Dispersion openings	1+1	29+31	0.25 NOK pr. gram	15,-
Lid	1	15	0.25 NOK pr. gram	3.75,-
Distributor	1	216	0.25 NOK pr. gram	54,-
Tape	1	-	60,-	(60,-)
Pipe clamp	2	-	44,3,-	(88.6,-)
<b>Total cost:</b>				<b>6686.6 NOK</b>

The tested setup from chapter 5.2 has been compared to the dispersion solutions from chapter 6. The complete dispersion system consists of the TSI Aerosol Generator 3076, diffusion dryer and a setup with pressurized air (Table 9-2). If the sandblaster can produce similar results as the aerosol generator, a 146 times price reduction can be made. If the diffusion dryer is taken into account as it is needed for wet dispersion, the price difference is several times higher than that.

*Table 9-2: Comparing prices of developed/found solutions and the tested setup from chapter 5.2.*

Possible price difference with tested setup	
Developed/found solutions	
Paint gun	660 NOK [82]
Sandblaster	199 NOK [83]
<b>Tested setup</b>	
Complete system	68-145,500 NOK (7-15,000 Euros)
Aerosol Generator	29,100 NOK (3,000 Euros)

**PART TWO: TESTING****10 TESTING OF TEST-RIG COMPONENTS**

---

*This chapter is going to include all testing of test-rig components and a simple assembly test. This is conducted to find the fan speed for the different voltages, so the rig flow can be controlled. Further finding the most efficient disperser. It will go through the necessary preliminary testing, the experimental setup, test conditions and data collection.*

**10.1 FAN TESTING****TEST GOALS**

- The air speed for voltages 0-16V will be tested for the fan.
- The fan plate's ability to lead air shall be tested.

**10.1.1 AIR VELOCITY EXAMINATION**

The air velocity meter, TSI model 8330 (Figure 10-1) was used to measure the air speed from the fan. It uses a thermal anemometer to read the air speed. Which consists of a wire heated to a temperature higher than the ambient air. As the air flows by the sensor (hot wire) it cools down, changing the electrical resistance in the wire. A correlation can be calculated between the resistance and air speed. It was said that it could be somewhat unreliable under 1 m/s, even though the manual said that it could measure down to under 0,25 m/s. In order to know if it was an accurate reading for all voltages a calculated air speed was produced. This was done by measuring the RPM at all voltages with the Onosokki HT-4100 digital tachometer. The air speed was measured at 16V where the meter was known to be in a reliable zone. An equivalent air velocity could then be calculated for the other voltages using the corresponding RPM. The recommended use stated in the datasheets was followed for both the TSI 8330 and HT-4100. To get an equivalent velocity for the other voltages this formula was used:

$$v = v_{16V} * \frac{RPM_{3-15V}}{RPM_{16V}} \quad (10.1)$$

The fan with the fan plate, was placed fastened to the fan holder at the end of a one meter long 125 mm ventilation pipe, where the meter was held at the other end. The 125 mm was used to simulate the setup and as it would create the highest velocity. The velocity meter was held at the same position for all velocity tests (Figure 10-1), to ensure that all tests had the same conditions. After some experimentation it was decided to hold it a little out to the side of the

pipe and not in the middle. This was done as the fan made a vortex giving the air at the sides a higher velocity. The meter was given some time to stabilize before reading the measurement.

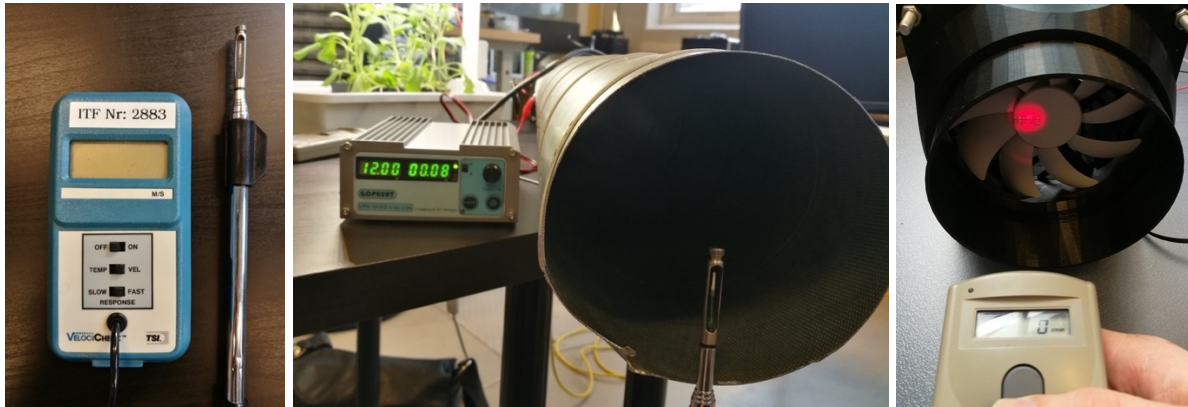

Figure 10-1: To the left: The TSI model 8330 air velocity meter. Middle: An overview of how the test was conducted. Right: How the RPM was measured.

As seen in Table 10-1, the measured air speed has a good correlation with the calculated one for most of the voltages. As predicted it got more unreliable with lower air speed. This does not have to be the air velocity meter, but can be the surrounding air that affects the measurement. In Figure 10-1 it can be seen how the RPM of the fan was measured. The tachometer uses light reflection to measure the RPM, therefore a reflecting tape was fastened to the back of the fan before measurement.

Table 10-1: The fan air speed for the voltage outputs and calculated air speed for 125 and 236 mm.

Voltage [V]	Measured Air velocity [m/s]	RPM	Calculated Air Speed [m/s]	Calculated 236 mm pipe velocity [m/s]
3	0.25	198	0.37	0.07
3.5	0.3	258	0.48	0.08
4	0.4	314	0.59	0.11
5	0.69	412	0.77	0.19
6	0.9	506	0.95	0.25
7	1.03	585	1.10	0.29
8	1.1	653	1.22	0.31
9	1.22	726	1.36	0.34
10	1.42	785	1.47	0.40
11	1.52	845	1.58	0.43
12	1.63	897	1.68	0.46
13	1.71	955	1.79	0.48
14	1.9	1000	1.87	0.53
15	1.94	1048	1.96	0.54
16	2.05	1094	2.05	0.58

The speed has been found for a 125 mm pipe. The particle velocity that is most relevant is for the 236 mm pipe. It is therefore necessary to calculate the equivalent velocity, using the continuity equation [84]. Calculations presented in Table 10-1. This has not taken into account losses.

$$v_1 * A_1 = v_2 * A_2 \rightarrow v_2 = \frac{v_1 * A_1}{A_2} \quad (10.2)$$

$v_1 = 125$  mm velocity,  $v_2 = 236$  mm velocity,  $A_1$  and  $A_2$  is the cross-section area for respectively 125 mm and 236 mm pipes.

### 10.1.2 FAN PLATE TEST

A simple test was conducted to confirm that the fan plate works as stated. The air velocity meter was placed as in Figure 10-2 and the air velocity was measured with and without the plate. What should happen is that with the plate the air speed should be lower or still at the sensor, but without the plate there should be significant air velocity. The velocity meter in Figure 10-2 was set up 15 cm left of the centre of the fan and 10 cm up. The test showed that with the plate the air was completely still, but without the plate the air had a speed of 0.3 m/s. So the fan plate worked as described, it forced the air to move in a more straight direction away from the fan.

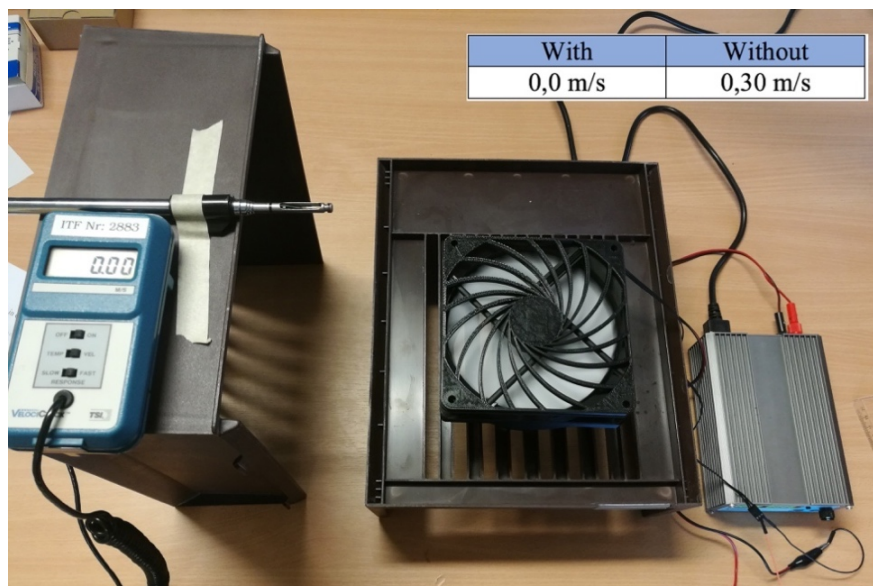

Figure 10-2: The test setup for the fan plate and the air velocity out to the side of the fan with and without the plate.

## 10.2 DISPERSION DEVICE TESTING

The dispersion devices put forth in the previous chapter has been tested to see which one disperses the particles most efficiently. Both the sandblaster and paint gun is going to be tested against each other, as well as against no dispersion device. The test was conducted with two

different sensors to see if the measurements match each other and to get a more complete result. The sensors bought in is the Plantower PMS5003 and the Nova Fitness SDS021.

### TEST GOALS

- Selected dispersion devices shall be tested and compared using two inexpensive particle sensors, monitoring with laser scattering.
- The efficiency of the sandblaster vs paint gun shall be found with the use of corn starch.
- The effectiveness dispersing the nano calcite powder will be found for the devices.
- Visual inspection of the different tests will be performed. Looking for the amount of suspended particles.
- A method for dispersing specific amounts of powder will be tested.
- If the dispersion devices cannot disperse the particles in a manner that gives out the particle sizes wanted, alternatives should be discussed.

#### 10.2.1 SENSOR SETUP

An Arduino is used as the controller for the particle sensors. Even though there is more elaborate and expensive controllers on the market, the Arduino has a lot to offer when it comes to experimental use. It is cheap, available and it can be programmed to do a wide variety of tasks, using the different input and output ports on the board. Further the code can be changed by the push of a button. This is beneficial when performing tests where rapid alterations can be needed.

The code for the PMS5003 uploaded to the Arduino, that is used to interpret the signals coming from the sensor (Figure 10-3), was mainly taken from a code written for the PMS5003 online [59], this is the same for the SDS021 [60]. Both the sensors measure once a second. Some alterations have been made to get the codes out in a more structured manner. The full codes are in appendix C & D.

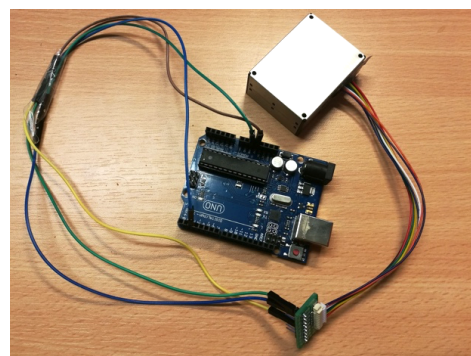
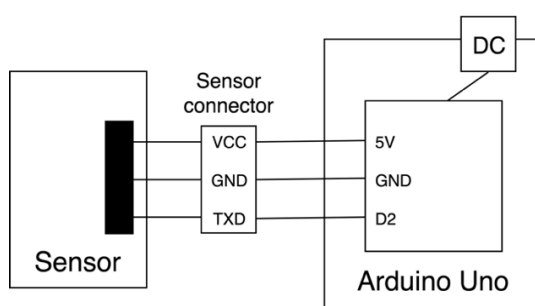
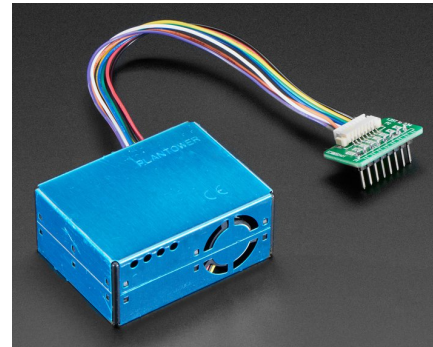

*Figure 10-3: How the PMS5003 sensor is connected to the Arduino. The VCC and GND is respectively positive and negative power, the TXD is the signal from the sensor.*

### PLANTOWER PMS5003

The Plantower particle sensor (Figure 10-4) is a low-cost particle sensor (specification in chapter 4.3). It uses laser scattering to measure particle concentration and categorizes the particle sizes into 6 size channels (PM0.3, PM0.5, PM1.0, PM2.5, PM5.0 and PM10).

A project on Researchgate called “Evaluation of low-cost PM sensors”, has a goal to understand the measurement uncertainty of these sensor types. They have tested the PMS5003 and concluded on some inaccuracies in its measurements. They have found that it has a relatively good accuracy for PM2.5, but gets a little more inaccurate for smaller particles. The PMS5003 can according to the experiment not measure particle sizes  $> 3 \mu\text{m}$ . When it



*Figure 10-4: The Plantower PMS5003. [59]*

outputs particle sizes over  $> 3 \mu\text{m}$  it only estimates on the basis of the particles it can measure ( $< 3 \mu\text{m}$ ), assuming that it has a wide-ranging particle distribution. The study concludes by putting forth a strong suspicion that low-cost sensors, mainly produced in china are made as PM2,5 and is extrapolating the PM10 values [85]. Therefore only particle size  $< 3 \mu\text{m}$  will be taken into account when determining particle dispersion with this sensor.

### NOVA FITNESS SDS021

The SDS021 (Figure 10-5) is as the PMS5003 a low-cost particle sensor (specification in chapter 4.3), using laser scattering to determine particle concentration for PM2.5 and PM10. This sensor does not have the ability like the PMS5003 to show the amount of particles in the air, only concentration. There was not found any previous studies conducted in the SDS021 that could give an indication into the accuracy of it. For the SDS021 PM2.5 and PM10 means the same as described in chapter 2.1.



*Figure 10-5: The Nova Fitness SDS021. [60]*

### 10.2.2 EXPERIMENTAL SETUP

To test the different dispersion devices a rig was made. It consist of:

- A 1.2 meter long ventilation pipe
- Two laser scattering particle sensors
- An Arduino Uno connected to the sensors, with the code to interoperate the signals
- A holder for the particle sensors
- A suction pipe to avoid accumulation of particles in the room
- A computer to log the measurements from the sensors
- Pressurized air source
- Dispersers: Sandblaster and paint gun
- Particle powder: Corn starch and nano calcite

The sensor holder is connected to one end of the pipe holding the two sensors (Figure 10-6). The sandblaster and paint gun will shoot the particles in the other end of the pipe, eventually passing the two sensors. To monitor the testing a computer was connected to one sensor at a time through the Arduino, logging all the data coming from the sensor. This was done because the two sensors use different code to be monitored. Between each test, the rig was clean with pressurized air. To ensure that residual particles from previous test, does not affect the next test. All tests have been conducted a minimum of 3 times to verify that any coincidence are detected. The pressurized air used has a pressure of 6-7 bar. This is nearly the same as the 90 psi that gave the best results in the vacuum ejector study [31].



*Figure 10-6: Here the experimental setup can be seen. Left: Showing two computers, only one was use at a time. Further showing the pipe which the particles enter and the suction pipe positioned behind the outlet of the pipe. Right: The sensor is fastened to the pipe using a sensor holder.*



The testing was conducted in the workshop of the RealTek faculty, which is an open environment. To take the possibility of changing air quality into account, the sensor measurement before dispersion was logged to see what conditions the environment had when testing. Testing was started when it had similar values as the last test.

Two different dispersion methods have been tested for the two devices:

1. The particle powder will be put in the canisters for the respective dispersion device (Figure 10-7). The pressurized air trigger will be push completely in for one second to disperse the particles. For this method the amount of powder dispersed will not be measured. The reason for this is that it is impossible to see if all the particles in the canister is dispersed or not.
2. The particle powder will be weighed to a specific weight, then placed in a funnel, making it possible to see that all the powder has been dispersed (Figure 10-7).



*Figure 10-7: A overview of the two different methods that have been tested. Left: With the canister, Right: With the funnel.*

### 10.2.3 CORN STARCH TESTING

Corn starch is as described in an early chapter, an inexpensive powder, which can have a particle size distribution from 0.1-0.8  $\mu\text{m}$  [76]. This size probably varies quite a lot depending on what types of brand is bought. Even so, this a powder with a small particle size and will therefore be used in testing. From Figure 10-8 it can be seen that the starch clusters together into large lumps. These large clusters can be difficult to break completely down. This has not been done anything about, in order to see which of the dispersion devices has the

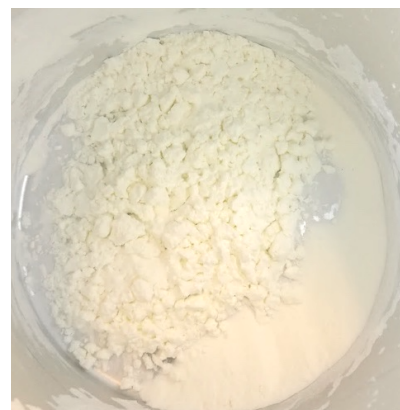

*Figure 10-8: Picture of the clusters in the corn starch.*

most success breaking them apart. Which is advantageous, as it will make it harder to disperse and therefore easier to see the effectiveness.

### SDS021 RESULTS

From Figure 10-9 it can be seen that sandblaster produces almost 10 times as much PM2.5 as the paint gun at their respective high points. The high areas are where the particle cloud from the disperser passes the sensor area, the rest is residual particles. It could be said that the sandblaster uses more powder than the paint gun during the one second spray. From observation from several tests this is not the case. It can quite clearly be seen through observation, that the paint gun uses more powder, but the particles are dispersed as larger particle clusters. These clusters are probably too large for either the PM2.5 or PM10 to measure. Only PM2.5 is shown as dispersion efficiency is tested. See whole data set in appendix G-H.

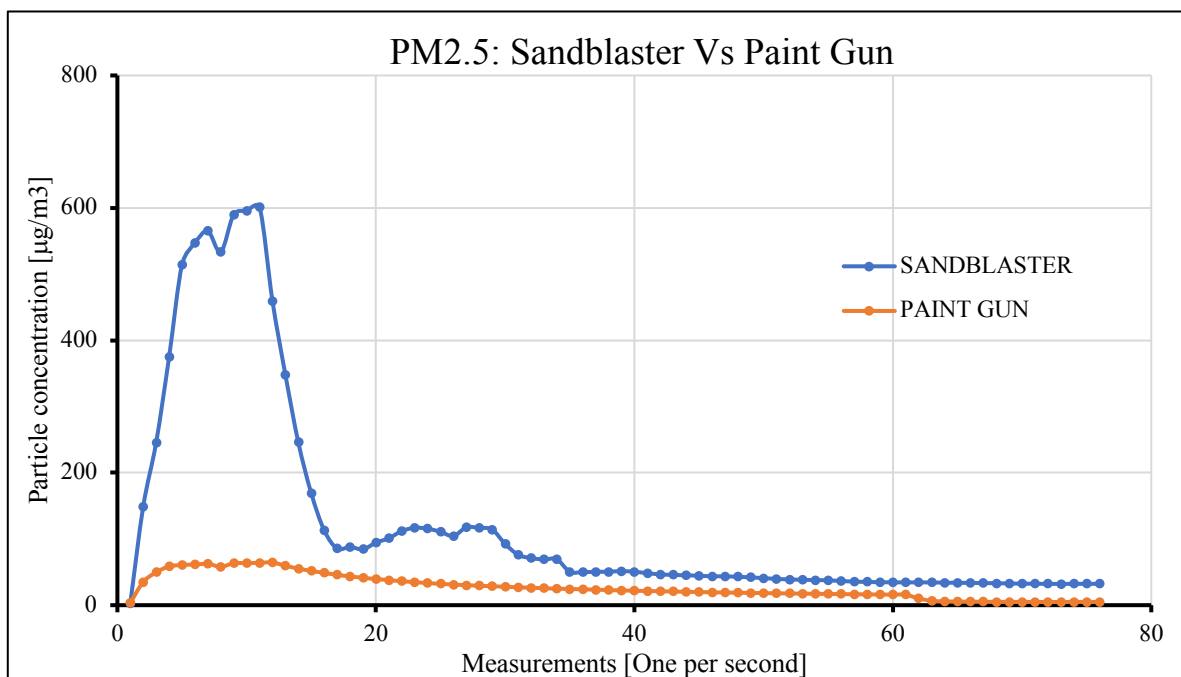

Figure 10-9: Comparing the SDS021 PM2.5 measurements for the sandblaster and paint gun.

Another indication that the sandblaster breaks the starch up more effectively can be seen in Figure 10-9. After the initial high peaks the particle concentration settles for a while before getting back to normal, indicating that it takes some time for the suspended particles to pass the system or fall to the ground. The paint gun reaches normal levels faster than the sandblaster, the little dip right after measurement 60 shows this. Suggesting the earlier observation that the particles from the paint gun is of a larger size, making the suspension time shorter.

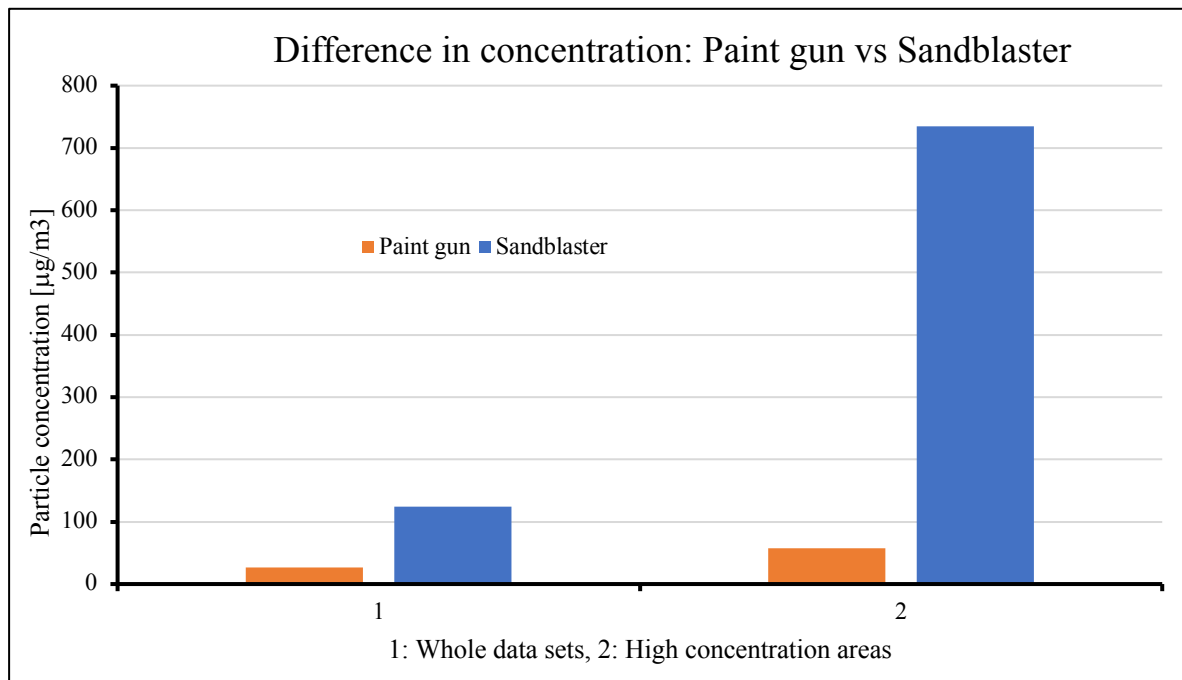

Figure 10-10: The difference in concentration for the whole data sets and the high concentration areas. For the paint gun and Sandblaster.

Comparing the average PM2.5 count for the 76 measurements, the Sandblaster has a 4.6 times higher µg/m3 count at 124.2 against the paint guns 27.1 (Figure 10-10). If only the measurements from the particle cloud is taken into account, it is 12.9 times as high (Data from number 2-16, appendix G-H). This was test 1, but test 2 and 3 also follow the same pattern. The paint gun has the ability to be adjusted and several adjustments were tested, but this was the best results. Further, going through all the tests it is clear that the sandblaster gives a more even blast, with a more similar concentration each time.

**PMS5003 RESULTS**

This trend can also be seen when measuring with the PMS5003. The different numbers from Table 10-2 are taken out from a continuous sampling sequence, to given an indication of the efficiency of the different dispersion devices. See whole data set in appendix E-F.

Table 10-2: Test of corn starch dispersion with different devices, measured with a Plantower PMS5003 particle sensor. Green: ideal particles orange: tolerable red: poor (these are not to be taken into account, only to show what the sensor measured)

Corn starch	PMS5003			
	Hand	Paint gun	Sandblaster	Just air
PM0.3	7308	6975	7086	800-1000
PM0.5	2288	2070	2024	140-200
PM1.0	907	508	356	10-15
PM2.5	281	115	58	0-2
PM5	99	42	21	0
PM10	25	17	4	0

The comparison is done by taking measurement with similar PM0.3 amounts for each device and comparing the different sizes against each other. From the table it can be seen that the sandblaster has a lower number of larger size particle than both the hand (particles blown from the hand, no disperser) and paint gun. “Just air” is there to indicate what the measurements were when just spraying pressurized air through the pipe. The sandblaster has half the PM2.5 that the paint gun indicating a more efficient dispersion.

#### 10.2.4 CALCITE TESTING

When using the same setup as for the corn starch with the calcite powder and sandblaster, the concentration reading for both sensors went up higher than for the starch (Figure 10-9). The powder should be uniformly sized at 0.9  $\mu\text{m}$  and should therefore produce a high concentration compared to the starch which has a unknown size distribution. The SDS021 has a maximum concentration value of respectively 999 and 1999  $\mu\text{g}/\text{m}^3$ , for the PM2.5 and PM10, which the readings reached (Table 10-3). The PMS5003 also reached similar values (PM10 for PMS5003, may be extrapolated as said earlier). The PM2.5 values gave a good sign that the particles are dispersed correctly, but the PM10 reading might seem alarming. But only a fraction of PM10 particles is need to get the same concentration as the PM2.5. If the dispersed particles mostly consist of 0.9  $\mu\text{m}$  particles, and the rest is somewhere in-between 2.5-10  $\mu\text{m}$ , giving it a conservative value of 5  $\mu\text{m}$ . Using these values and a simple calculation, the amount of PM2.5 particles needed is 171 times as high as the amount of PM10 particles needed (calculation in appendix I). This makes the results less alarming then they might have seemed at first glance.

*Table 10-3: Peak concentration value for the calcite dispersion, read by the SDS021 and PMS5003.*

Peak concentration value [ $\mu\text{g}/\text{m}^3$ ]		
	SDS021	PMS5003
PM2.5	999	1138
PM10	1999	1780

#### 10.2.5 TESTING OF SPECIFIC POWDER AMOUNT

Both the sandblaster and paint gun was tested with powder in the canisters and a one second trigger. The funnel was also tested (Figure 10-11), with one gram of starch/calcite that was placed in the funnel for dispersion. Through testing and observation it was clear, that one gram of powder was too much. With one gram the whole sensor area pipe was filled with a thick opaque particle cloud of suspended particles (Figure 10-11).

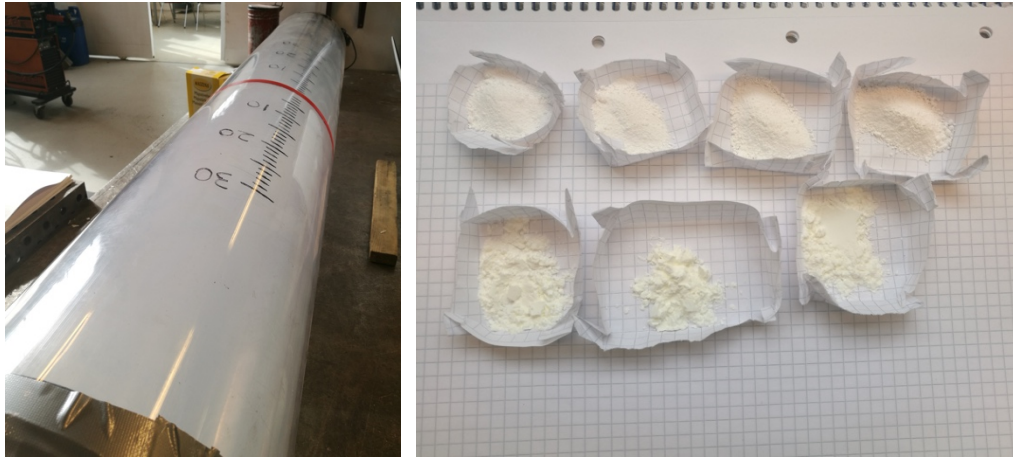

*Figure 10-11: Left: How one gram of calcite fill the entire transparent sensor area pipe. Right: The 1 gram measurements for funnel testing. The difference in powder clustering can be seen (calcite above)*

Through the use of the sandblaster it was found that it is preferable that the particles are sucked up into the dispersion area using vacuum, instead of being dropped into the funnel. Using the intended upwards vacuum, distributes the particles more uniformly making it easier for the disperser. When using the funnel, much of the powder is dropped into the dispersion area before the pressurized air is turn on, making it difficult for the disperser to do its job. For the funnel to work a mesh of some sort can be fitted down in the funnel for the particles to lie on. When the pressurized air is turn on the particles will be pull through the mesh, being distributed more evenly. This was tested using a thin piece of steel wool to get a proof of concept. The wool can be seen as a type of mesh as it has some small openings, the particle laid on top of it until the pressurized air was turned on, creating a pressure difference pulling the particles through.

### **10.3 CIRCULATION TESTING FULL RIG**

To get an indication of how accurate the flow simulations are, a test has been conducted. Using nearly the full test-rig, the ability of the distribution device (solution 3) to extinguish the rotational motion made by the fan was tested. First testing without any distribution device to see if the particles actually rotated, and then with the device. Showing if the particles move in the same manner as the flow simulation calculated.

The test used the setup in Figure 10-12, including the whole test-rig, except for one of the turns. The fan speed was set to 16V, to get a worst case. The particles were dispersed into the system using the sandblaster at the end of the ventilation pipe, before the fan. The tested showed that without the distribution device the particles had a rotational movement, cause by the fan. With the distribution device, no rotation could be observed. Concluding that the simulation was correct.



Figure 10-12: Setup used to test the rotational motion of the air, with and without the distribution device. Arrow showing the direction of the particle flow. Picture taken in-between testing.

## 10.4 TESTING SUMMARY

From the testing some results can be put down. Of the two dispersion devices it was the sandblaster using the vacuum ejector solution that was most efficient distributing the different particles. The results from the different test are presented in Table 10-4, together with appropriate consequence/action that should be taken.

Table 10-4: Overview of the test results and the possible resulting consequence/action that should be taken.

Fan test	Result	Consequence/action
Air velocity	Results as expected.	-
Fan plate	Results as expected.	-
Dispersion test	Result	Consequence/action
Starch paint gun	Results showed that it could not disperse properly.	Not to be tested further.
Starch sandblaster	Results showed a good dispersion efficiency compared to the paint gun.	Further testing should be done.
Calcite sandblaster	The results showed the uniformity of the calcite and the ability of the sandblaster to disperse.	A vacuum ejector with 1mm nozzle should be tested.
Canister	Results showed that dispersing the powder from the canister is preferable.	See possible alteration in next test.
Specific powder amount	Results showed that 1 gram of powder is too much.	A mesh is needed to be placed in funnel.
Dispersion test	Result	Consequence/action
Rotation	Results showed similarities to the flow simulations, showing the extinction of the rotational motion.	-

## 11 DISCUSSION & PROCESS EVALUATION

---

*This chapter will discuss the results gotten through the development and testing of the test-rig. Further evaluation how the different steps of the process have gone.*

### 11.1 DISCUSSION OF RESULTS

The results from thesis is a culmination of the research and selection, as well as flow simulation and testing. The results discussion is divided into the relevant steps of the development. Discussing the objectives for the thesis and the goals for the development.

#### FLOW SIMULATIONS

The results from the flow simulation was produced through numerical, visual and statistical methods. This was done to get a broad pictures of the flow design, will being limited to the one flow simulation software. All the results has its limitations as they are produced using several assumptions within the flow simulation software.

The statistical travel time analysis is done using 150 particle paths giving individual travel times for each of them. This gives a large dataset for every solution to calculated the coefficient of variation. The paths not reaching the end was taken away from all datasets, taking away some inaccuracies. Solution 3 gave the best results, eliminating the rotational motion created by the fan, uniformly distributing the particles and having the most even time through the system. Coming in at a coefficient of variation of 10.8%. As it takes some time for the particle velocity to reach the uniformity it would be ideal to place the sensors at the bottom end of the sensor area pipe. If further testing is going to be done, setups using different fan speeds would be a good idea, as the assembly has the possibility of altering the air speed.

#### FAN SETUP

The results for the fan speed testing gave expected values. As the velocity meter was said to somewhat inaccurate, a calculated air speed was performed. These speed matched up making the values from the meter more credible than expected. The results from the fan gave a good air velocity range. The highest at 2.05 m/s and lowest at 0.25 m/s for a 125 mm pipe. As the sensor area pipe is 236 mm the respective velocities were 0.58 and 0.07. Having the possibility for very low speeds and high speeds, which can be pulsated using the relay setup. The fan plate worked as described, and can help the air move more unidirectional through the pipes.

## DISPERSION

The results from the corn starch testing were clear, the sandblaster came out more efficient than the paint gun. The SDS021 gave results where the sandblaster had a 12.9 times higher PM<sub>2.5</sub> dispersion than the paint gun. The PMS5003 also showed that the sandblaster dispersed the particles in a more efficient way. Some discrepancies between the two sensor results were found, indicating inaccuracies with the testing and/or the sensors, both being equally possible. But the difference in dispersion is so large that it is fairly safe to say that the sandblaster is most efficient at dispersing the corn starch powder. Which is corroborated with theory and other testing [31].

For the calcite test, the dispersion with the sandblaster gave results implying that the sandblaster mostly disperses particles under 2.5 µg/m<sup>3</sup>. Indicating that the sandblaster is able to disperse the particles in an efficient manner. It is not possible to see if the sandblaster actually dispersed the particles completely. Therefore further research needs to be conducted to find a viable test, which can confirm this. Testing with a better sensor could give a more accurate picture of the efficiency of the sandblaster, or comparing the results using an SMPS. A 1 mm nozzle vacuum ejector connected to a pressure of 90 psi could possibly produce a higher dispersion efficiency. Through research, it was concluded that the amount of particle powder should be above 200 mg to get an optimal dispersion. Testing and observation found 1 gram of powder to be too much.

When comparing the price of the TSI Aerosol Generator 3076 and the sandblaster from Biltema, it has a price difference of 146 times or more. Further testing done with a higher quality sensor, can give a clearer picture and from there make it possible to drastically decrease the expenses of dispersing powder in an efficient way.

## 11.2 PROCESS DISCUSSION

It was initially a goal that the CMUT sensor would be tested with the test-rig. But it was early set as a limitation as it was unclear when the sensor would arrive and it would be too time consuming to execute within the time parameters. It was concluded that it was more important to invest the time getting a deep theoretical understanding of the subject, putting the efforts into the development work. On the basis of the development specifications, several choices for components were made, limiting the options and creating a foundation for the development.

The component review gave back new possibilities to control the test-rig. On the background of keeping things simple, the adjustable power supply was selected to control the fan speed. Which gave the idea to go one step further, controlling the on off cycle of the fan, using a simple



Arduino relay setup. The sandblaster was first theoretically researched before it was found in the workshop together with a paint gun, giving the idea that both should be tested. The research made into finding suitable particles to test the CMUT sensor was comprehensive, as prices were exceeding the budget limits. The nano calcite particles found at Nanografi were within the budget parameters and delivered uniformly sized particles. The spherical shape of the particles were again limited by the budget.

The iterating part of the development, including CAD drawing and flow simulations gave new insight and understanding to the problems surrounding the project. Through simulation of the distribution solutions new and simpler ideas were created, solving the problem with a one part solution instead of three. It gave valued results, but the flow simulation was also more time consuming than first thought. Getting the parameters correct, so the simulation would give out as precise results as possible was challenging.

The testing of two dispersion devices was conducted in a workshop using two inexpensive particle sensors. As the testing was conducted in an environment which was not controlled, certain uncertainties need to be taken into account. Measures were taken to compensate for this: Having equal starting measurements, cleaning the rig in-between testing etc. A clean room, where the air has gone through a filter would have been optimal.

#### **DEVELOPMENT IMPROVEMENTS**

- Previously tested test-rigs could have been further investigated.
- Could have used more of the available expertise at the University to acquire knowledge about theory surrounding the project.



## 12 CONCLUSION

---

*In this chapter the completion of the objectives and presentation the results will be put forth. Further suggesting recommendations and future work.*

### 12.1 COMPLETION OF OBJECTIVES

Theoretical research and investigation, including the current test-rig and tested setups, gave way to initial test-rig development specifications and solution recommendations for testing. A suitable distribution device was found through flow simulation. Necessary base components to control the rig were established. Leading to drawings and pictures of the final test-rig and its components. Particles that could be used for preliminary testing and full scale testing were found and bought. Through further development, possible dispersion devices were discovered, and later tested with the particle bought in. A dispersion device that gave results of efficiency were found, concluding that further testing was needed. Ending with building the room to house the test-rig.

### 12.2 DEVELOPMENT RESULTS

Here the main results and finding are presented, giving a conclusion to the project and thesis.

#### MAIN RESULTS & FINDINGS

- A test-rig that is interchangeable into the three different setup has been made. Making the test-rig compatible with a variety of sensors. Costing approximately 6686.6 NOK.
- A inexpensive dispersion device that costs 199 NOK compared the commercially available at 29,100 NOK, have been studied and tested. The sandblaster gave results that indicates a high dispersion efficiency of suspended particles. Further research is needed into finding a test that can conclusively say if the sandblaster dispersed the particles well enough. Testing with higher quality sensors or an SMPS should be conducted.
- Flow simulation using Solidworks has been conducted for the test-rig. Finding a distribution device, which distributes the particles uniformly and with a relatively uniform velocity. The results from Solidworks have through testing been found correct.
- The rig dimensions: Roughly 2.5m tall due to fitting etc. (2469 mm in assembly, appendix A), sensor area pipe is 1365 mm. The large size is mainly due to the long

sensor area pipe. Which has this length to give the particles time to uniformly distribute, and pass the sensor at the same velocity.

- Results show that a funnel should not be used for accurate dispersion without a mesh/holder to place the particles on, as the particles will drop into the dispersion area making it difficult to disperse properly.
- Results and studies show that the amount of particles used for dispersion should be above 200 mg and below 1000 mg.
- A fan assembly has been created with adjustable velocity control and a flow directing fan plate. Further a relay setup has been made, making it possible to pulsate the fan.
- Vacuum ejectors were studied, showing promising results and with a low price making it a solution that should be tested.
- One size of uniform particles have been found and bought. Several others have been researched and it is possible to buy if needed.

## 12.3 RECOMMENDATIONS & FUTURE WORK

This section is dedicated to recommendations and future work, through development or acquisitions.

### DEVELOPMENT

- When the CMUT sensor is ready for testing the area on the sensor area pipe where it is going to be fitted, need to be cut out. A universal mount should be made to fit other sensor types, that is relevant for testing.
- More permanent gaskets for the parts that do not have it should be made, making the rig more complete.
- Finish the construction of the test-rig room. Installing air suction and a clean air system in the housing module to ensure high quality measurements. This can be done using a hepa filter in the air intake.
- Install a fine mesh in the funnel for the particles to lay on. This to avoid particle accumulation in the dispersion area of the sandblaster. Doing so makes it possible to disperse a specific amount of particles.
- Conduct further research of tested particle sensor calibration studies, using their data to compare with the future data acquired from the CMUT sensor.
- If certain parts of the assembly is going to be changed, allocate enough time to research in order to prevent otherwise unforeseen mistakes.

**ACQUISITIONS**

- Purchase a vacuum ejector with a 1 mm nozzle (proven most efficient) to test against the sandblaster (2,5 mm), as the sandblaster uses the same principle. Installing the ejector with a valve, the assembly can be mounted permanently to the test-rig.
- To have a high quality and exact reference point to compare the results gotten from the CMUT sensor, it should be considered buying in a SMPS (scanning mobility particle sizer spectrometer) or similar, for comparison.
- Purchase and test with several different uniformly sized particles sizes, to get a broad comparison basis.
- For wet dispersion testing, an aerosol generator together with a diffusion dryer (Chapter 5.2) can be used to for high accuracy testing.
- A sharp cut cyclone can be used to separate PM2.5 and PM10 or other sizes into different areas, so they can be monitored independently. With this device two sensors can be used with a smaller size spectrum instead of one with a large spectrum. This may increase the accuracy of the CMUT sensor.



---

## 13 REFERENCES

---

- [1] Folkehelseinstituttet, "Luftkvalitetskriterier: Virkninger av luftforurensning på helse," Folkehelseinstituttet, 2013.
- [2] W. H. Organization, "Ambient air pollution: a global assessment of exposure and burden of disease," World Health Organization , 2016.
- [3] Fluenta , "About Fluenta and ultrasonic sensing technology," [Online]. Available: <https://www.fluenta.com/about/>. [Accessed 25 April 2018].
- [4] World Health Organization , "9 out of 10 people worldwide breathe polluted air, but more countries are taking action," 2 May 2018. [Online]. Available: <http://www.who.int/news-room/detail/02-05-2018-9-out-of-10-people-worldwide-breathe-polluted-air-but-more-countries-are-taking-action>. [Accessed 3 May 2018].
- [5] WHO, "World Health Organization," 2016. [Online]. Available: [http://www.who.int/phe/health\\_topics/outdoorair/databases/cities/en/](http://www.who.int/phe/health_topics/outdoorair/databases/cities/en/). [Accessed 31 January 2018].
- [6] D. Carrington, "The Guardian," 8 January 2016. [Online]. Available: <https://www.theguardian.com/environment/2016/jan/08/london-takes-just-one-week-to-breach-annual-air-pollution-limits> . [Accessed 25 January 2018].
- [7] D. Carrington, "The Guardian," 30 January 2018. [Online]. Available: Damian Carrington. [Accessed 31 January 2018].
- [8] WHO, "World health Organization," September 2016. [Online]. Available: <http://www.who.int/mediacentre/factsheets/fs313/en/>. [Accessed 20 January 2018].
- [9] Cassee FR, Fokkens PHB, Leseman D, HJTh B, Boere AJF, "Respiratory allergy and inflammation due to ambient particles (RAIAP) collection of particulate matter samples from 5 European sites," Rijksinstituut voor Volksgezondheid en Milieu RIVM;, 2003.
- [10] M. M. Maricq, "Chemical characterization of particulate emissions from diesel engines: A review," ScienceDirect, 2007.
- [11] Brent Stephens, Parham Azimi, Zeineb El Orch, Tiffanie Ramos, "Ultrafine particle emissions from desktop 3D printers," ScienceDirect, 2013.
- [12] World Health Organization , "WHO Air quality guidelines for particulate matter, ozone, nitrogen dioxide and sulfur dioxide," World Health Organization .
- [13] S. Berg, "Capacitive micromachined ultrasonic transducers: Acoustic challenges and proposed solutions," NTNU, 2012.
- [14] Nikhil Apte, Kwan Kyu Park, Amin Nikoozadeh and Butrus T. Khuri-Yakub, "Bandwidth and Sensitivity Optimization in CMUTs for Airborne Applications," Department of Mechanical Engineering, Hanyang University, Seoul, Republic of Korea, 2014.
- [15] Khuri-Yakub Group, Stanford University, "Khuri-Yakub Group: Brief history of CMUTs," [Online]. Available: <https://web.archive.org/web/20110720052401/http://www->

- kyg.stanford.edu/khuriyakub/opencms/en/research/cmuts/History/index.html. [Accessed 29 January 2018].
- [16] Phillips Innovation services, "CMUT breakthrough ultrasound technology," [Online]. Available: <https://www.innovationservices.philips.com/looking-expertise/mems-micro-devices/mems-applications/capacitive-micromachined-ultrasonic-transducers-cmut/>. [Accessed 29 March 2018].
- [17] Khuri-Yakub Group, Stanford University, "Khuri-Yakub Group: General Description and Advantages of CMUTs," [Online]. Available: <https://web.archive.org/web/20110720050202/http://www-kyg.stanford.edu/khuriyakub/opencms/en/research/cmuts/general/index.html>. [Accessed 29 January 2018].
- [18] Particle sciences, drug development services, "Particle Size Distribution and its Measurement," Particle sciences, drug development services, 2009.
- [19] Horiba instruments, INC, "A guidebook to particle size analysis," Horiba instruments, INC, 2017.
- [20] Nnamdi V. Ogueke, Nwabueze Emekwuru, "Regulation of Nanorefrigerant Use: A Proactive Measure Against Possible Undesirable Health and Environmental Implications," *European Journal of Sustainable Development Research*, 1:2, 09, 2017.
- [21] A. Tsuda, F. S. Henry and J. P. Butler, "Particle transport and deposition: basic physics of particle kinetics," 2013.
- [22] Yaobo Ding, Burkhard Stahlmecke, Heinz Kaminski, Yunhong Jiang, Thomas A. J. Kuhlbusch & Michael Riediker, "Deagglomeration testing of airborne nanoparticle agglomerates: Stability analysis under varied aerodynamic shear and relative humidity conditions," *Aerosol Science and Technology*, 2016.
- [23] Store Norsk Leksikon, "brownske bevegelser," 24 December 2011. [Online]. Available: [https://snl.no/brownske\\_bevegelser](https://snl.no/brownske_bevegelser). [Accessed 19 April 2018].
- [24] G. Calvert, M. Ghadiri, R. Tweedie, "Aerodynamic dispersion of cohesive powders: A review of understanding and technology," *Institute of Particle Science and Engineering, University of Leeds*, 2008.
- [25] Sympatec GmbH, "Glossary: Dry Dispersion," [Online]. Available: <https://www.sympatec.com/en/particle-measurement/glossary/dry-dispersion/>. [Accessed 6 April 2018].
- [26] Sympatec GmbH, "Glossary: Wet Dispersion," [Online]. Available: <https://www.sympatec.com/en/particle-measurement/glossary/wet-dispersion/>. [Accessed 6 April 2018].
- [27] Umang V. Shaha, Vikram Kardeb, Chinmay Ghoroi, Jerry Y.Y. Henga, "Influence of particle properties on powder bulk behaviour and processability," *International Journal of Pharmaceutics*, 2016.
- [28] Libretexts Chemistry, "Cohesive and Adhesive Forces," 29 August 2017. [Online]. Available: [https://chem.libretexts.org/Core/Physical\\_and\\_Theoretical\\_Chemistry/Physical\\_Properties\\_of\\_Matter/States\\_of\\_Matter/Properties\\_of\\_Liquids/Cohesive\\_and\\_Adhesive\\_Forces](https://chem.libretexts.org/Core/Physical_and_Theoretical_Chemistry/Physical_Properties_of_Matter/States_of_Matter/Properties_of_Liquids/Cohesive_and_Adhesive_Forces). [Accessed 19 April 2018].
- [29] B. Zhao, W.J. Brittain, "Polymer brushes: surface-immobilized macromolecules," *ELSEVIER*, 2000.



- [30] Claudius Weiler, Markus Wolkenhauer, Michael Trunk, Peter Langguth, “New model describing the total dispersion of dry powder agglomerates,” 1. Boehringer Ingelheim Pharma GmbH & Co. KG, 55216 Ingelheim, Germany 2. Johannes Gutenberg-University Mainz, Institute of Pharmacy, Germany, 2010.
- [31] P. Tang, D.F. Fletcher, H.-K. Chan, J.A. Raper, “Simple and cost-effective powder disperser for aerosol particle size measurement,” Powder Technology, 2008.
- [32] Ajit Jillavenkatesa, Stanley J. Dapkunas, Lin-Sien H. Lum, “Particle Size Characterization,” 2001.
- [33] Simone Simões Amaral, João Andrade de Carvalho Jr, Maria Angélica Martins Costa, Cleverson Pinheiro, “An Overview of Particulate Matter Measurement Instruments,” Atmosphere, 2015.
- [34] Ronald E. Lacey & William Brock Faulkner, “Uncertainty associated with the gravimetric measurement of particulate matter concentration in ambient air,” Journal of the Air & Waste Management Association, 2015.
- [35] Sympatec GmbH, “Glossary: Dynamic light scattering,” 2018. [Online]. Available: <https://www.sympatec.com/en/particle-measurement/glossary/dynamic-light-scattering/>. [Accessed 29 March 2018].
- [36] HORIBA Scientific, “Particle characterization: Dynamic light scattering,” 2018. [Online]. Available: [http://www.horiba.com/scientific/products/particle-characterization/technology/dynamic-light-scattering/?L=0tx\\_horibatx\\_horibafeuserregister\\_pi1%5Bcmd%5Dtx\\_horibafeuserregister\\_pi1%5Bcmd%5Dtx\\_horibafeuserregister\\_pi1%5Bcmd%27%22](http://www.horiba.com/scientific/products/particle-characterization/technology/dynamic-light-scattering/?L=0tx_horibatx_horibafeuserregister_pi1%5Bcmd%5Dtx_horibafeuserregister_pi1%5Bcmd%5Dtx_horibafeuserregister_pi1%5Bcmd%27%22). [Accessed 29 March 2018].
- [37] Sympatec GmbH, “Particle measurement: Dynamic image analysis,” 2018. [Online]. Available: <https://www.sympatec.com/en/particle-measurement/sensors/dynamic-image-analysis/>. [Accessed 29 March 2018].
- [38] Earth system research laboratory: Global monitoring division, “Aerosol Group: Three Wavelength Integrating Nephelometer,” 2018. [Online]. Available: [https://www.esrl.noaa.gov/gmd/aero/instrumentation/neph\\_desc.html](https://www.esrl.noaa.gov/gmd/aero/instrumentation/neph_desc.html). [Accessed 29 Mars 2018].
- [39] Malvern Panalytical, “Laser diffraction: Malvern Panalytical,” 2018. [Online]. Available: <https://www.malvernpanalytical.com/en/products/technology/light-scattering/laser-diffraction>. [Accessed 29 Mars 2018].
- [40] Sympatec GmbH, “Glossary: Laser diffraction, Sympatec,” 2018. [Online]. Available: <https://www.sympatec.com/en/particle-measurement/glossary/laser-diffraction/>. [Accessed 29 March 2018].
- [41] HORIBA scientific, “Particle characterization: laser diffraction,” 2018. [Online]. Available: [http://www.horiba.com/scientific/products/particle-characterization/technology/laser-diffraction/?L=0tx\\_horibatx\\_horibafeuserregister\\_pi1%5Bcmd%5Dtx\\_horibafeuserregister\\_pi1%5Bcmd%5Dtx\\_horibafeuserregister\\_pi1%5Bcmd%27%22](http://www.horiba.com/scientific/products/particle-characterization/technology/laser-diffraction/?L=0tx_horibatx_horibafeuserregister_pi1%5Bcmd%5Dtx_horibafeuserregister_pi1%5Bcmd%5Dtx_horibafeuserregister_pi1%5Bcmd%27%22). [Accessed 29 March 2018].
- [42] Retsch Technology GmbH, “Comparison Between Dynamic Image Analysis, Laser Diffraction and Sieve Analysis,” [Online]. Available: <https://www.azom.com/article.aspx?ArticleID=14331>. [Accessed 2017 August 9].

- [43] HORIBA Scientific, “Dynamic image analysis technology,” 2018. [Online]. Available: <http://www.horiba.com/scientific/products/particle-characterization/technology/dynamic-image-analysis/> . [Accessed 29 March 2018].
- [44] GRIMM, “ENVIRO-EDM365,” [Online]. Available: [http://wiki.grimm-aerosol.de/images/5/53/GRIMM\\_EDM\\_365\\_datasheet.pdf](http://wiki.grimm-aerosol.de/images/5/53/GRIMM_EDM_365_datasheet.pdf). [Accessed 3 April 2018].
- [45] GRIMM, “ENVIRO-EDM665,” [Online]. Available: [http://wiki.grimm-aerosol.de/images/a/a4/D\\_E\\_WRAS-665\\_rev1p1.pdf](http://wiki.grimm-aerosol.de/images/a/a4/D_E_WRAS-665_rev1p1.pdf). [Accessed 3 April 2018].
- [46] Laftech, “Grimm EDM365 Series Advanced Dust Monitoring Stations,” [Online]. Available: <http://laftech.com.au/product/grimm-edm-365-transportable-fixed-outdoor-environmental-dust-monitor/>. [Accessed 3 April 2018].
- [47] Laftech, “GRIMM EDM 665 Wide Range Aerosol Spectrometer,” [Online]. Available: <http://laftech.com.au/product/grimm-edm-665-wide-range-aerosol-spectrometer/>. [Accessed 3 April 2018].
- [48] HORIBA Scientific, “Continuous particulate monitor with x-ray fluorescence px-375,” [Online]. Available: [https://static.horiba.com/fileadmin/Horiba/Products/Process%20and%20Environmental/Ambient/Brochures/PX-375\\_HRE-2341E.pdf](https://static.horiba.com/fileadmin/Horiba/Products/Process%20and%20Environmental/Ambient/Brochures/PX-375_HRE-2341E.pdf). [Accessed 25 March 2018].
- [49] Aeroqual , “Dust Profiler – Dust and Particle Counter,” [Online]. Available: <https://www.aeroqual.com/wp-content/uploads/Dust-Profiler-Brochure.pdf>. [Accessed 3 April 2018].
- [50] AQMesh, “A revolution in air quality monitoring,” [Online]. Available: <https://www.aqmesh.com/wp-content/uploads/2016/05/AQMesh-brochure-May-2016.pdf>. [Accessed 3 April 2018].
- [51] AQMesh, “AQMesh low-cost outdoor air quality monitor,” [Online]. Available: <https://www.aqmesh.com/product/>. [Accessed 3 April 2018].
- [52] Naneos, “Partector,” [Online]. Available: <http://www.naneos.ch/partector.html> . [Accessed 3 April 2018].
- [53] Naneos, “Partector Aerosol Dosimeter,” [Online]. Available: [http://www.naneos.ch/pdf/naneos\\_partector\\_operation\\_manual.pdf](http://www.naneos.ch/pdf/naneos_partector_operation_manual.pdf). [Accessed 3 April 2018].
- [54] Aeroqual, “Portable Air Quality Monitors,” [Online]. Available: <https://d2pwrxbx99jwry6.cloudfront.net/wp-content/uploads/Aeroqual-Portable-Monitors-Long-Brochure-LR.pdf>. [Accessed 3 April 2018].
- [55] Naneos, “Price list 2018,” [Online]. Available: [http://www.naneos.ch/pdf/pricelist\\_2018.pdf](http://www.naneos.ch/pdf/pricelist_2018.pdf) . [Accessed 3 April 2018].
- [56] Ohoo Air , “The Most Advanced Indoor Air Toxin Sensor,” [Online]. Available: <https://uhooair.com/> . [Accessed 6 April 2018].
- [57] Honeywell, “HPMA115S0-XXX,” [Online]. Available: <https://sensing.honeywell.com/HPMA115S0-XXX-particle-sensors>. [Accessed 5 April 2018].
- [58] TME Electronic components, “HONEYWELL HPMA115S0-XXX,” [Online]. Available: [https://www.tme.eu/en/details/hpma115s0-xxx/gas-sensors/honeywell/?brutto=1&gclid=Cj0KCQjwqYfWBRDPARIsABjQRYzIJRzj8MulXOTXnmGkOnUe\\_IFf46pAw1fBUfwiEfrjCMK5qXngM9QaAmSFEALw\\_wcB](https://www.tme.eu/en/details/hpma115s0-xxx/gas-sensors/honeywell/?brutto=1&gclid=Cj0KCQjwqYfWBRDPARIsABjQRYzIJRzj8MulXOTXnmGkOnUe_IFf46pAw1fBUfwiEfrjCMK5qXngM9QaAmSFEALw_wcB) . [Accessed 5 April 2018].

- [59] Adafruit, "PM2.5 Air Quality Sensor and Breadboard Adapter Kit - PMS5003," [Online]. Available: <https://www.adafruit.com/product/3686>. [Accessed 5 April 2018].
- [60] Sparkfun, "Particle Sensor 2.5PM and 10PM - SDS021," [Online]. Available: <https://www.sparkfun.com/products/retired/14309>. [Accessed 5 April 2018].
- [61] MIT technology Review, "An Air-Quality Monitor You Take with You," 18 August 2014. [Online]. Available: <https://www.technologyreview.com/s/530011/an-air-quality-monitor-you-take-with-you/>. [Accessed 05 february 2018].
- [62] Chemisense, "Intelligent & Connected Environmental Sensing," 2015. [Online]. Available: <https://chemisense.co/features/>. [Accessed 05 february 2018].
- [63] ChemiSense, "ChemiSense: Personal air quality monitors," [Online]. Available: <https://angel.co/chemisense>. [Accessed 18 Mars 2018].
- [64] Office of Research and Development: National Exposure Research Laboratory, "Evaluation of Field-deployed Low Cost PM Sensors," United States Environmental Agency , 2014.
- [65] Jiayu Li, Pratim Biswas, "Optical Characterization Studies of a Low-Cost Particle Sensor," Aerosol and Air Quality Research, 2017.
- [66] Yang Wang, Jiayu Li, He Jing, Qiang Zhang, Jingkun Jiang, Pratim Biswas, "Laboratory Evaluation and Calibration of Three Low-Cost Particle Sensors for Particulate Matter Measurement," Aerosol Science and Technology, 2015.
- [67] Fractal Design, "Silent Series R3 140mm," [Online]. Available: <http://www.fractal-design.com/home/product/casefans/silent-series-r3/silent-series-r3-140mm>. [Accessed 17 April 2018].
- [68] Gopher Technology, "16V 10A Adjustable DC Power Supply," [Online]. Available: <http://gophertc.com/en/16v-10a-adjustable-dc-power-supply>. [Accessed 17 April 2018].
- [69] Q. Boney, "Laminar Flow Fan plate," 18 August 2014. [Online]. Available: <https://www.thingiverse.com/thing:432630> . [Accessed 17 April 2018].
- [70] HORIBA Instruments, Inc., "Optimization of Dry Powder Particle Size Analysis," HORIBA Instruments, Inc., 2014.
- [71] P. Rajniak, K. Dhanasekharan, C. Sinka, N. MacPhail and R. Chern, "Modeling and measurement of granule attrition during pneumatic conveying in a laboratory scale system," Powder Technology , 2018.
- [72] Schmalz, "Vacuum Ejectors," [Online]. Available: <https://www.schmalz.com/en/vacuum-knowledge/the-vacuum-system-and-its-components/vacuum-generators/vacuum-ejectors/>. [Accessed 18 April 2018].
- [73] Graco, "Atomization Concept and Theory," [Online]. Available: [http://wwwd.graco.com/training/concept\\_and\\_theory/Atomization%20v2.pdf](http://wwwd.graco.com/training/concept_and_theory/Atomization%20v2.pdf). [Accessed 18 April 2018].
- [74] Nanografi , "Nanocalcite, %99.9, 900nm," [Online]. Available: <https://nanografi.com/special-materials/nanocalcite-99-9-900nm/> . [Accessed 20 February 2018].
- [75] National Center for Biotechnology Information. PubChem Compound Database, "Calcium Carbonate," [Online]. Available: [https://pubchem.ncbi.nlm.nih.gov/compound/calcium\\_carbonate#section=Health-Hazard](https://pubchem.ncbi.nlm.nih.gov/compound/calcium_carbonate#section=Health-Hazard). [Accessed 8 April 2018].

- [76] Engineering Toolbox, "Particle Sizes: Sizes of airborne particles as dust, pollen bacteria, virus and many more," [Online]. Available: [https://www.engineeringtoolbox.com/particle-sizes-d\\_934.html](https://www.engineeringtoolbox.com/particle-sizes-d_934.html). [Accessed 15 April 2018].
- [77] Lúis Mendes, Anneli Kangas, Kirsi Kukko, Bjarke Mølgaard, Arto Säämänen, Tomi Kanerva, Iñigo Flores Ituarte, Marika Huhtiniemi, Helene Stockmann-Juvala, Jouni Partanen, Kaarle Hämeri, Konstantinos Eleftheriadis, Anna-Kaisa Viitan, "Characterization of Emissions from a Desktop 3D Printer," Department of Physics, Division of Atmospheric Sciences, University of Helsinki, Helsinki, Finland, 2017.
- [78] Parham Azimi, Dan Zhao, Claire Pouzet, Neil E. Crain, Brent Stephens, "Emissions of Ultrafine Particles and Volatile Organic Compounds from Commercially Available Desktop Three-Dimensional Printers with Multiple Filaments," *Environmental Science & Technology*, 2015.
- [79] Sun Zaia, Huang Zhena, Wang Jia-song, "Studies on the size distribution, number and mass emission factors of candle particles characterized by modes of burning," *Journal of Aerosol Science*, 2006.
- [80] Gabriel Bekö, Charles J. Weschler, Aneta Wierzbicka, Dorina Gabriela Karottki, Jørn Toftum, Steffen Loft, and Geo Clausen, "Ultrafine Particles: Exposure and Source Apportionment in 56 Danish Homes," *Environmental Science & Technology*, 2013.
- [81] Ski Bygg, "Ventilasjon," [Online]. Available: <https://www.skibbygg.no/produkter/ventilasjonststyr-sentralstovsuger/ventilasjon.html>.
- [82] Spray-Equipment, "ASTURO E70," [Online]. Available: [http://www.spray-equipment.net/143\\_Airbrushes-with-cup/ASTURO-E70/](http://www.spray-equipment.net/143_Airbrushes-with-cup/ASTURO-E70/). [Accessed 3 May 2018].
- [83] Biltema, "Punktsandblåser," [Online]. Available: <http://www.biltema.no/no/Verktoy/Trykkluft/Sandblasing/Punktsandblaser-2000028446/>. [Accessed 3 May 2018].
- [84] I. H. Brevik, 2013.
- [85] B. Laquai, "Particle Distribution Dependent Inaccuracy of the Plantower PMS5003 low-cost PM-sensor," *Research Gate*, 2017.
- [86] Particle technology labs, "Particle technology labs," 2018. [Online]. Available: <https://www.particletechlabs.com/analytical-testing/particle-size-distribution-analyses/sieve-analysis>. [Accessed 21 March 2018].
- [87] S. Gunaratna, "CBS News: This state has the worst air quality in the nation," 20 June 2017. [Online]. Available: <https://www.cbsnews.com/news/worst-air-quality-california/>. [Accessed 21 January 2018].
- [88] J. Berlinger, S. George and S. Wang, "CNN: Beijing's smog: A tale of two cities," 16 January 2017. [Online]. Available: <https://edition.cnn.com/2017/01/15/health/china-beijing-smog-tale-of-two-cities/index.html>. [Accessed January 21 2018].

## 14 APPENDICES

---

- A: Test-rig with main dimensions
- B: Exploded view of test-rig
- C: Plantower PMS5003 Arduino code
- D: Nova Fitness SDS021 Arduino code
- E-F: Data from the Pantower PMS5003
- G-H: Data from the Nova Fitness SDS021
- I: Concentration calculation for dispersion testing
- J: Quality Assurance
- K: Methodology
- L: Mesh Cut Plot
- M-P: Flow Simulation Statistics Data Set

# Appendix A: Test-rig with main dimensions

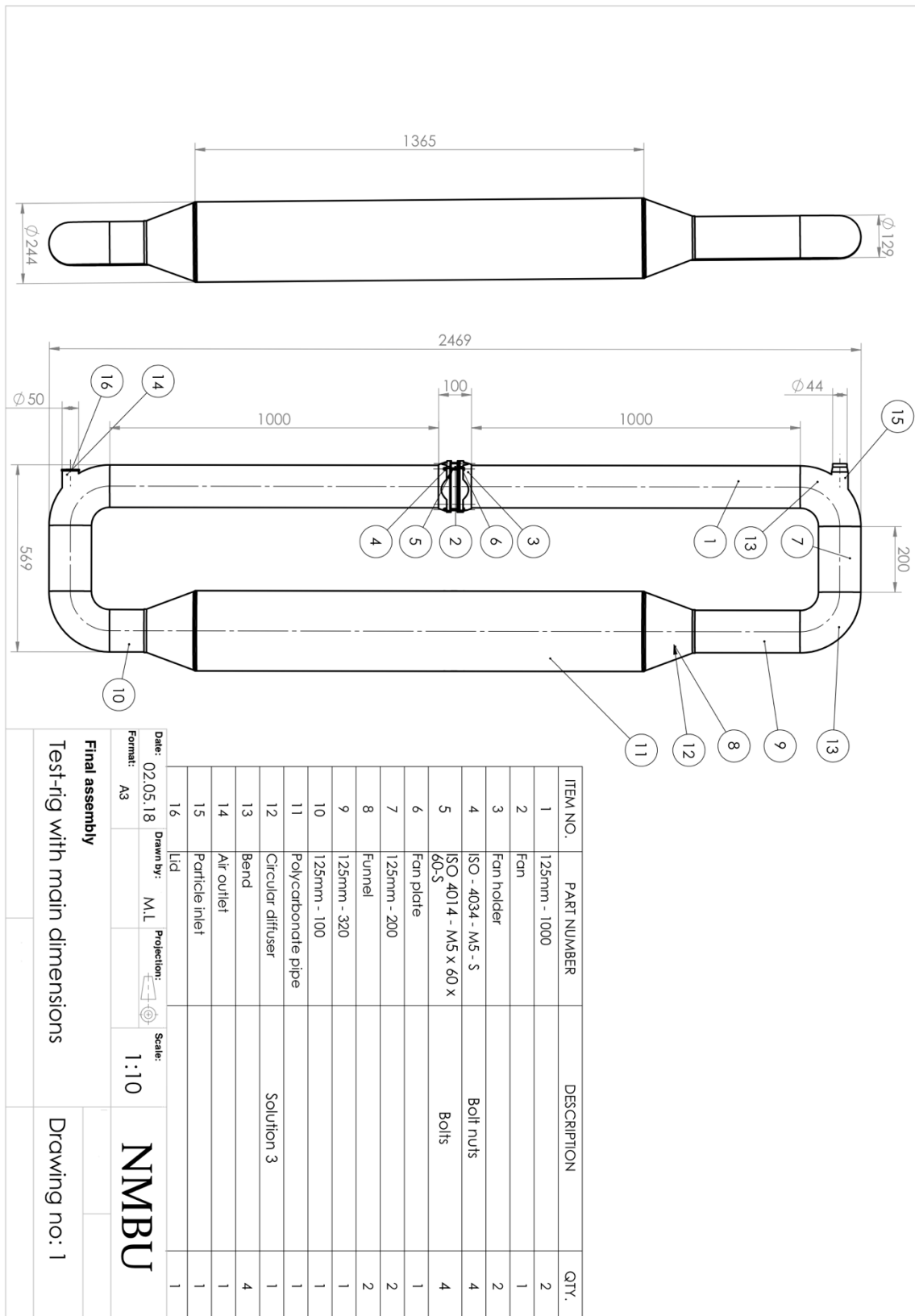

## Appendix B: Exploded view of test-rig

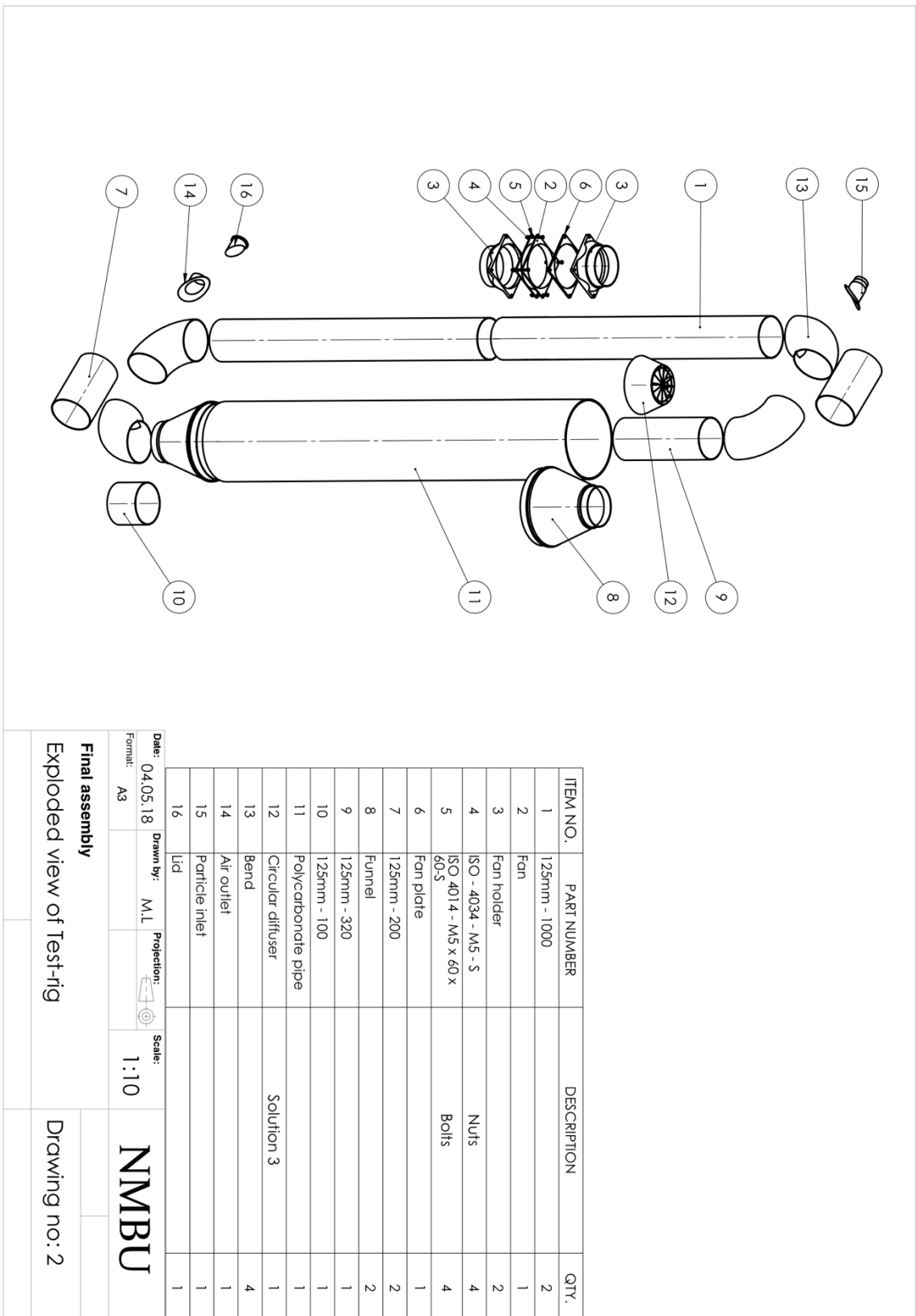

## Appendix C: Plantower PMS5003 Arduino code

```
#include <SoftwareSerial.h>
SoftwareSerial pmsSerial(2, 3);
void setup() {
  Serial.begin(115200);
  pmsSerial.begin(9600);
}
struct pms5003data {
  uint16_t framelen;
  uint16_t pm10_standard, pm25_standard, pm100_standard;
  uint16_t pm10_env, pm25_env, pm100_env;
  uint16_t particles_03um, particles_05um, particles_10um, particles_25um, particles_50um, particles_100um;
  uint16_t unused;
  uint16_t checksum;
};
struct pms5003data data;
void loop() {
  if (readPMSdata(&pmsSerial)) {
    Serial.println();
    Serial.println("-----");
    Serial.println("Concentration Units (standard)");
    Serial.print("PM 1.0: "); Serial.print(data.pm10_standard);
    Serial.print("\t\tPM 2.5: "); Serial.print(data.pm25_standard);
    Serial.print("\t\tPM 10: "); Serial.println(data.pm100_standard);
    Serial.println("-----");
    Serial.println("Concentration Units (environmental)");
    Serial.print("PM 1.0: "); Serial.print(data.pm10_env);
    Serial.print("\t\tPM 2.5: "); Serial.print(data.pm25_env);
    Serial.print("\t\tPM 10: "); Serial.println(data.pm100_env);
    Serial.println("-----");
    Serial.print("Particles > 0.3um / 0.1L air:"); Serial.println(data.particles_03um);
    Serial.print("Particles > 0.5um / 0.1L air:"); Serial.println(data.particles_05um);
    Serial.print("Particles > 1.0um / 0.1L air:"); Serial.println(data.particles_10um);
    Serial.print("Particles > 2.5um / 0.1L air:"); Serial.println(data.particles_25um);
    Serial.print("Particles > 5.0um / 0.1L air:"); Serial.println(data.particles_50um);
    Serial.print("Particles > 10 um / 0.1L air:"); Serial.println(data.particles_100um);
    Serial.println("-----");
  }
}
boolean readPMSdata(Stream *s) {

  if (! s->available()) {
    return false;
  }
  if (s->peek() != 0x42) {
    s->read();
    return false;
  }
  // Now read all 32 bytes
  if (s->available() < 32) {
    return false;
  }
  uint8_t buffer[32];
  uint16_t sum = 0;
  s->readBytes(buffer, 32);

  // get checksum ready
  for (uint8_t i=0; i<30; i++) {
    sum += buffer[i];
  }
  uint16_t buffer_u16[15];
  for (uint8_t i=0; i<15; i++) {
    buffer_u16[i] = buffer[2 + i*2 + 1];
    buffer_u16[i] += (buffer[2 + i*2] << 8);
  }

  memcpy((void *)&data, (void *)buffer_u16, 30);

  if (sum != data.checksum) {
    Serial.println("Checksum failure");
    return false;
  }
  return true;
}
```



## Appendix D: Nova Fitness SDS021 Arduino code

```
#include <SoftwareSerial.h>

SoftwareSerial particleSensor(10, 11); // RX, TX

float pm25; //2.5um particles detected in ug/m3
float pm10; //10um particles detected in ug/m3

void setup()
{
  Serial.begin(9600);
  Serial.println("Particle Sensor Example");

  particleSensor.begin(9600);
}

void loop()
{
  if (dataAvailable())
  {
    Serial.print("Particle Matter [2.5]:");
    Serial.print(pm25, 1);
    Serial.print("ug/m3 [10]:");
    Serial.print(pm10, 1);
    Serial.print("ug/m3");
    Serial.println();
  }
  else
  {
    Serial.println("Timeout or CRC error");
    Serial.println("Double check blue wire goes to pin 10");
  }

  delay(5);
}

boolean dataAvailable(void)
{
  long startTime = millis();

  while (1)
  {
    while (!particleSensor.available())
    {
      delay(1);
      if (millis() - startTime > 1500) return (false);
    }

    if (particleSensor.read() == 0xAA) break;
  }

  byte sensorValue[10];
  for (byte spot = 1 ; spot < 10 ; spot++)
  {
    startTime = millis();
    while (!particleSensor.available())
    {
      delay(1);
      if (millis() - startTime > 1500) return (false);
    }

    sensorValue[spot] = particleSensor.read();
  }

  //Check CRC
  byte crc = 0;
  for (byte x = 2 ; x < 8 ; x++) //DATA1+DATA2+...+DATA6
    crc += sensorValue[x];
  if (crc != sensorValue[8])
    return (false); //CRC error

  //Update the global variables
  pm25 = ((float)sensorValue[3] * 256 + sensorValue[2]) / 10;
  pm10 = ((float)sensorValue[5] * 256 + sensorValue[4]) / 10;

  return (true);
}
```

## Appendix E-F: Data from Plantower PMS5003

### SANDBLASTER TEST 1-1: CORN STARCH

PM0.3	PM0.5	PM1.0	PM2.5	PM5.0	PM10	Total
198	55	10	2	0	0	265
1593	424	8	2	1	0	2028
2313	619	70	6	4	1	3013
3435	952	134	24	12	2	4559
4377	1228	193	33	15	2	5848
5049	1429	242	39	16	2	6777
5619	1594	276	47	17	3	7556
6114	1743	309	51	18	3	8238
6630	1892	334	54	18	3	8931
7086	2024	356	58	21	4	9549
7380	2107	384	62	22	4	9959
6165	1796	401	64	21	4	8451
5673	1672	360	69	22	6	7802
4719	1390	314	55	15	6	6499
4719	1390	314	55	15	6	6499
3870	1142	261	46	12	6	5337
3309	973	220	43	11	6	4562
2817	829	190	36	11	5	3888
					Total:	109761

### PAINT GUN TEST 1-1: CORN STARCH

PM0.3	PM0.5	PM1.0	PM2.5	PM5.0	PM10	
180	36	4	1	0	0	221
2049	598	141	32	13	3	2836
4095	1224	328	73	27	12	5759
5520	1654	435	106	40	15	7770
6510	1928	428	112	41	16	9035
6975	2070	508	115	42	17	9727
7644	2271	542	123	43	17	10640
7878	2344	556	124	43	17	10962
8013	2380	568	124	43	17	11145
8082	2405	572	125	43	17	11244
6276	1866	437	94	30	14	8717
4374	1287	267	59	17	5	6009
3000	873	166	27	4	2	4072
2019	605	125	21	3	1	2774
2019	605	125	21	3	1	2774
1599	478	103	19	2	0	2201
1599	478	103	19	2	0	2201
1599	478	103	19	2	0	2201
					Total :	110288

**HAND TEST 1-1: CORN STARCH**

PM0.3	PM0.5	PM1.0	PM2.5	PM5.0	PM10	Total
1113	259	54	21	3	0	1450
3072	874	278	72	20	4	4320
4317	1287	483	138	49	10	6284
7308	2288	907	281	99	25	10908
9315	2915	1130	332	118	31	13841
11043	3484	1375	417	155	42	16516
13128	4126	1576	458	167	43	19498
15480	4877	1791	514	178	47	22887
17511	5511	2001	565	191	48	25827
19635	6191	2185	616	200	52	28879
19788	6201	2090	697	195	51	29022
20943	6512	2039	563	169	45	30271
21510	6616	1943	513	153	45	30780

## Appendix G-H: Data from Nova Fitness SDS021

Number	Sandblaster		Paint gun	
	PM2.5	PM10	PM2.5	PM10
1	3,1	50,9	3,6	187,9
2	149	511,3	35	273,7
3	245,6	656,1	49,7	341,1
4	374,5	831,1	58,5	355,8
5	514,2	890	60,7	366
6	547	931,9	61,4	369,3
7	565	960,7	62,4	343,7
8	533,5	974,8	58,1	374,5
9	589,9	908,8	63,3	378,9
10	595,7	993,3	63,6	380,5
11	601,3	998,8	64	355,4
12	459,4	1003,7	64,5	332,3
13	348,1	545,7	59,5	313,2
14	245,9	365,6	55,3	295,9
15	169,1	258,2	51,7	280,6
16	113,2	182,3	48,7	296,6
17	85,6	143,4	45,8	256,2
18	88	121,4	43,5	246
19	84,4	124,3	41,3	236,5
20	94,4	127,9	39,5	228,7
21	101	145,6	37,8	221,1
22	111,9	162,4	36,2	213,7
23	116,9	172,7	34,8	207,1
24	115,6	177,8	33,4	200,9
25	110,8	178	32,2	195,6
26	104,5	172,6	31,1	190,4
27	117,5	165	30,2	186
28	116,7	180,8	29,3	191,4
29	114,2	181,6	28,6	177,1
30	92,6	183,7	27,8	173,2
31	76,3	162,4	27	169,9
32	71	137,5	26,3	166,1
33	69,2	131,1	25,6	162,8
34	69,3	129,3	24,9	159,7
35	50,5	129,5	24,4	156,8
36	49,8	108	23,9	153,9
37	50,4	106,8	23,4	151,2

38	50,5	105,6	22,8	148,7
39	51,4	104,8	22,3	146,3
40	50,5	102,4	21,8	144
41	48,3	101,5	21,4	141,8
42	46,5	98,8	21	139,8
43	45,7	96,4	20,6	137,8
44	45,1	95,6	20,2	135,9
45	44,5	94,4	19,8	134,1
46	43,6	93,5	19,4	132,3
47	43,6	93,5	19,1	130,7
48	42,8	92,7	18,8	129,2
49	42	91,9	18,5	127,7
50	40,8	90,3	18,2	126,3
51	39,7	88,8	17,9	124,9
52	38,8	87,4	17,7	123,5
53	38,4	87,1	17,4	122,2
54	37,9	86,9	17,2	120,9
55	37,5	86,7	16,9	119,7
56	36,5	85,4	16,7	118,5
57	35,6	84,5	16,5	117,5
58	35,1	83,7	16,3	116,6
59	34,7	83,1	16,1	115,6
60	34,5	82,8	15,9	90,3
61	34,4	83,2	15,8	70,9
62	34,4	82,9	10,1	62,4
63	34,3	82,7	6,6	59,8
64	34	82,3	5,8	57,6
65	33,8	81,9	5,4	57,5
66	33,6	81,7	5,3	56,8
67	33,4	81,4	5,1	56,9
68	33,1	81	5	56,2
69	32,8	80,5	4,9	56
70	32,5	81,1	4,9	55,5
71	32,4	80	4,9	55,5
72	32,2	79,9	4,8	55,3
73	32,1	79,7	4,8	55,3
74	32,2	80,1	4,9	55,3
75	32,2	80,4	4,9	55,2
76	32,2	80,7	4,8	55,1
Total:	9438,7	17622,3	2057,5	13155,3
Average:	124,193421	231,872368	27,0723684	173,096053

## Appendix I: Concentration calculations for calcite dispersion

Assuming  $PM_{2,5} = 0.9 \mu\text{m}$  and an average  $PM_{10} = 5 \mu\text{m}$ . By calculating the particle volume for the respective sizes, the concentration fraction can be determined:

$$V_{sphere} = \frac{4 * \pi * r^3}{3}$$

$$V_{PM_{2,5}} = \frac{4 * \pi * 0,45^3}{3} = 0,382$$

$$V_{PM_{10}} = \frac{4 * \pi * 2,5^3}{3} = 65,5$$

$$\text{Concentration fraction} = \frac{V_{PM_{10}}}{V_{PM_{2,5}}} = \frac{65,5}{0,382} = 171,4$$

## **Appendix J: Quality assurance**

To ensure a high quality of this project and thesis, several different factors have been taken into account to certify this. This include how theory has been found, which computer software has been used etc.

### **THEORY & SOURCES**

All the significant theory found and collected through this thesis has been found using certified scientific databases, journals and books. Other references from product sites etc. has been uses when conducting market research. It has been strived towards using articles or other forms of sources that are frequently cited. This can be difficult when researching very specific topics, therefore some deviation from this norm has been done, within scientific journal/articles. Further, every sources used through the thesis as well as possible been cross-checked with another.

### **COMPUTER SOFTWARE**

Through the project different computer software has been used. These are presented below.

#### **SOLIDWORKS 2017-2018, DASSAULT SYSTEMS, SP 4.1**

This program has been used for 3D-modeling of the product and its components. Furthermore, it has been used for rendering of 3D models. It has also been used to make technical drawings.

#### **SOLIDWORKS 2017-2018, DASSAULT SYSTEMS, SP 4.1, FLOW SIMULATION**

The flow simulation add-in in Solidworks was used to get an overview of the different possible test-rigs without having to make them. Seeing the air and particle flow and from there optimize the rig.

#### **MICROSOFT OFFICE 2011 (WORD, EXCEL)**

The entire report has been written in Word, the references have also been made through word. Excel has been uses to perform statistical analysis of the different datasets gathered throughout the development.

#### **PHOTOSHOP, DRAW.IO & SOLIDWORKS**

Photoshop, draw.io (Internet site) and solidworks has been used to create sketches and illustration for the thesis. These programs have often be used in collaboration to create informative figures.

## **Appendix K: Methodology**

### **METHODS AND TOOLS**

#### **INTEGRATED PRODUCT DEVELOPMENT (IPD)**

Integrated product development is a product development methodology used to achieve higher efficiency, lower completion time and a better learning outcome when carrying out development projects. It takes traditional product development and turns it on its head. Instead of developing a product and then finding a market and customers, you'll instead find the market and your customers very early in development process. The basis for this is to see the whole picture and get an overview of the concept early in the process. By doing the process this way, ideas might come that would not otherwise. IPD can be seen as a "checklist" of elements that should be included in a product development project. Iterations and data overlap between the 4 main groups, development, production, economy and HSE.

#### **PUGH'S METHOD**

Pugh's method is a selection process/tool used to compare different concepts and/or problems in order to make the right choice based on the given criteria's. The criteria are selected on the basis of the importance of the final solution. Furthermore, the criteria can also be weighted relative to each other in relevance to the project. The concepts are then given grades up against these criteria to finally arrive at a concept with the highest score. This method can be used in order to proceed with the best solution possible.

#### **MATERIALS**

In the development of this test-rig the material choices is not to important when it comes to strength. It is not a construction that need to withstand a lot of forces, so the materials used will be selected on the basis of requirements, availability and price.

#### **PRODUCTION METHODS**

##### **3D-PRINTING**

A readily available production method is 3D-printing, this makes the production of custom-built parts efficient and inexpensive. The 3D-printing makes it possible to test out different parts without having to wait for someone to make it.

##### **REALTEK WORKSHOP**

All work done to complete the rig except for the 3D-printing has been conducted in the faculty of science and technologys workshop facilities. This includes drilling, cutting, testing etc.



## Appendix L: Mesh Cut Plot

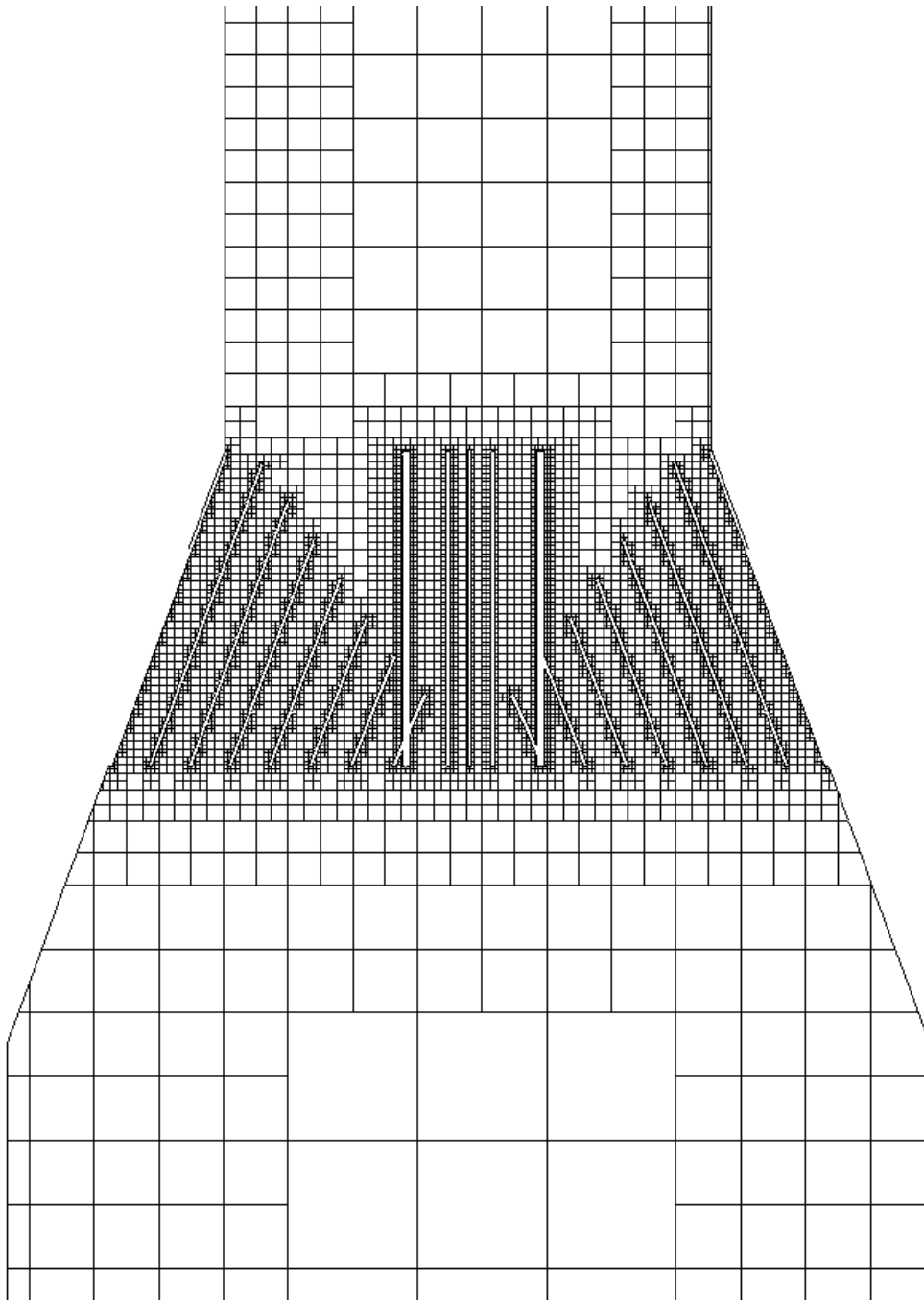

**APPENDIX M-P: FLOW SIMULATION STATISTICS DATA SET**

Number	Solution 3	Solution 2	Solution 1				Nothing
			DIF 1	DIF 2	DIF 3	ALL	
1	3,556	4,474	3,151	4,364	3,159	4,442	3,209
2	3,483	4,048	3,189	3,957	3,216	4,598	3,152
3	3,579	4,799	3,502	3,832	3,192	4,55	3,191
4	3,609	4,712	3,746	4,055	3,058	4,501	3,211
5	3,583	4,412	3,522	4,603	3,122	4,754	3,015
6	3,795	3,217	5,061	4,169	3,812	4,333	2,882
7	3,813	3,252	3,049	4,507	3,123	4,515	2,812
8	3,755	3,451	3,731	4,814	8,89	5,645	3,22
9	3,443	3,477	3,09	4,049	3,129	5,228	3,232
10	3,429	3,821	3,532	4,524	3,433	4,453	2,898
11	3,541	3,237	3,284	4,293	6,279	4,515	2,743
12	4,441	3,442	3,968	4,278	3,146	4,4	2,968
13	3,238	5,341	3,963	3,972	2,986	4,335	3,198
14	3,121	3,608	3,295	4,131	3,592	4,298	2,794
15	3,56	3,72	3,952	3,932	3,905	5,007	3,471
16	3,494	3,669	3,177	3,757	3,272	5,237	3,502
17	4,018	3,28	5,147	4,563	3,249	4,47	3,677
18	3,791	3,398	3,405	4,26	3,674	4,477	3,423
19	3,368	3,696	3,602	3,73	8,071	4,4	3,408
20	3,338	3,243	3,527	3,878	3,337	4,715	2,858
21	3,459	3,257	3,162	4,442	3,008	4,431	3,399
22	3,508	3,383	3,109	4,56	3,891	4,316	2,705
23	3,936	3,982	3,667	4,765	3,048	4,937	3,07
24	3,189	3,424	3,299	3,599	3,253	4,301	2,783
25	3,233	3,402	3,601	3,632	3,619	4,311	3,62
26	3,178	3,433	3,535	3,449	3,668	4,236	3,325
27	3,155	4,316	3,623	3,998	3,532	4,154	3,675
28	3,442	3,5	3,283	3,756	2,983	4,419	2,881
29	4,162	3,882	4,09	4,704	3,515	4,374	3,606
30	3,166	5,376	3,327	3,501	3,254	5,167	3,27
31	3,121	3,674	3,34	3,76	3,765	4,351	2,792
32	3,444	3,258	3,575	4,176	3,128	4,29	2,983
33	3,22	3,37	3,805	4,5	3,549	4,495	3,197
34	3,687	3,514	3,537	3,809	3,736	4,996	3,139
35	3,568	3,87	3,178	4,115	2,976	4,469	3,02
36	3,6	3,656	3,461	4,118	5,043	4,172	2,817
37	3,456	3,591	3,626	3,881	3,354	4,693	3,277
38	3,187	3,384	3,201	3,634	3,084	3,977	3,019
39	3,147	3,789	3,556	3,788	4,762	5,26	3,33
40	3,697	3,649	3,329	4,097	3,936	4,711	4,577
41	3,848	3,625	3,88	3,866	3,024	4,323	3,086

42	3,351	3,471	3,339	3,511	3,387	4,144	3,548
43	3,19	4,024	3,351	3,713	2,991	4,13	3,26
44	3,159	3,56	7,096	3,814	3,742	4,34	3,782
45	3,413	3,096	3,118	4,265	3,457	4,489	2,989
46	3,552	3,403	3,589	4,392	3,005	4,087	2,651
47	3,895	4,069	3,631	3,807	3,327	4,272	3,175
48	3,531	4,218	4,31	3,999	8,424	4,971	2,753
49	3,539	3,554	3,4	4,539	8,116	4,343	3,205
50	3,843	3,396	3,616	4,066	3,784	4,525	3,081
51	3,632	3,421	3,56	3,486	3,841	4,154	2,863
52	3,188	5,675	3,214	4,57	3,031	4,865	3,021
53	3,441	3,606	3,346	4,537	3,145	4,606	4,211
54	4,252	3,923	4,204	3,763	3,503	4,436	3,016
55	3,456	3,933	4,308	4,051	2,955	4,423	2,985
56	3,195	3,406	3,274	7,475	3,514	3,962	2,797
57	3,079	4,569	3,695	3,827	3,06	3,851	3,35
58	3,377	3,1	3,124	4,023	6,128	4,668	3,566
59	3,162	3,415	3,555	3,952	4,06	4,384	2,67
60	4,279	3,54	3,135	4,91	3,012	4,285	3,089
61	3,528	4,587	3,464	3,606	3,198	4,352	2,728
62	3,34	4,21	3,839	3,713	3,372	4,507	2,858
63	3,739	3,87	3,564	4,128	5,778	4,29	3,054
64	4,092	3,508	3,144	4,032	5,229	4,155	3,035
65	3,118	3,46	3,52	4,464	3,638	4,293	2,934
66	3,283	3,6	3,144	3,491	5,8	4,203	2,863
67	3,841	3,277	3,269	4,589	3,021	4,772	10,532
68	3,488	3,929	3,782	3,783	3,751	10,403	4,198
69	3,264	4,091	3,104	3,828	3,177	4,345	3,203
70	3,068	3,233	4,466	3,86	3,547	4,664	3,144
71	3,086	4,056	3,574	4,024	5,747	4,11	3,26
72	3,161	3,27	3,665	3,796	3,577	4,363	3,179
73	4,169	3,402	3,189	3,959	3,406	4,533	2,725
74	3,42	3,511	3,794	3,862	5,643	5,245	3,103
75	3,253	3,959	4,351	4,032	3,522	4,708	2,803
76	3,408	3,714	3,163	3,947	3,158	4,473	2,86
77	3,891	3,634	3,188	4,337	3,665	4,535	2,989
78	3,204	3,574	3,218	4,381	3,637	4,066	3,034
79	3,178	3,416	3,521	3,994	3,757	4,527	3,145
80	3,875	3,796	3,099	3,772	4,09	4,308	2,915
81	3,392	3,851	3,184	4,032	3,327	4,997	7,584
82	3,303	3,093	3,992	4,234	3,582	5,07	5,075
83	3,093	4,539	3,286	4,083	3,471	4,507	3,659
84	3,185	3,206	3,367	3,872	3,051		3,158
85	3,502	3,332	3,07	4,47	3,397		3,149
86	3,906	3,51	3,766	4,274	4,365		4,298

87	3,271	3,436	3,969	3,649	3,334		2,805
88	3,162	3,52	3,709	4,058	4,408		3,097
89	3,359	3,244	3,782	4,884	4,665		2,798
90	3,929	3,593	3,161	4,111	5,018		2,898
91	3,144	3,442	3,842	4,309	3,399		3,653
92	3,224	3,636	3,882	3,564	3,245		3,51
93	3,859	3,903	3,352	3,825	7,311		3,112
94	3,165	3,396	3,371	4,255	8,04		2,917
95	3,043	3,344	3,39	3,464	5,18		5,751
96	3,085	3,552	3,037	4,508	3,553		3,32
97	3,093	3,419	3,084	3,799	3,394		3,601
98	3,517	3,125	3,167	3,844	3,094		3,1
99	3,916	3,857	3,823	4,414	3,194		4,029
100	3,166	3,087	3,208	3,784	3,536		2,969
101	3,253	3,115	3,188	3,785	3,462		3,175
102	3,556	3,836	3,192	4,172	4,651		4,81
103	4,23	3,26	3,261	4,314	3,409		2,834
104	3,218	3,494	3,041	4,153	3,015		2,885
105	3,674	4,738	3,16	3,819	2,964		3,122
106	4,253	3,396	3,404	3,937	3,068		3,116
107	3,057	4,091	3,933	3,786	3,227		2,956
108	3,083	3,39	3,27	4,062			5,989
109	3,102	3,256	3,296	4,384			4,115
110	3,588	3,335	3,033	4,34			2,931
111	4,254	3,656	3,21	3,83			2,901
112	4,164	3,513	3,347	4,029			3,075
113	3,295	3,35	3,16	8,477			3,136
114	3,444	3,426	3,309	4,363			3,154
115	3,752	3,722	3,876	3,934			3,098
116	3,203	3,344	3,156	3,848			3,023
117	3,04	3,353	3,895	3,943			3,01
118	3,753	3,343	3,133	3,7			3,134
119	3,187	3,414	3,104	3,918			5,179
120	3,299	3,402	3,124	4,186			4,669
121	3,46	4,226	3,65	8,848			3,2
122	4,082	3,204	3,239	4,167			4,152
123	4,225	3,187	3,148	4,135			2,791
124	4,1	3,436	3,158	4,56			3,085
125	4,012	3,649	3,226	3,787			2,917
126	3,334	3,853	4,552	4,119			3,664
127	3,076	3,218	3,208	3,807			3,593
128	4,318	3,373	3,239	4,536			2,896
129	3,758	3,347	4,278	4,372			4,959
130	4,21	3,791	3,048	3,86			4,918
131	4,649	3,531	3,147	6,082			4,696

132	4,211	3,908	3,211				3,037
133	4,248	4,14	3,829				4,461
134	3,329	3,842	4,795				2,879
135	3,101	3,73	3,214				4,503
136	4,146		3,046				2,978
137	4,318		3,153				4,717
138	3,554		3,412				2,921
139	3,655		3,052				3,198
140	3,876		3,075				3,25
141	4,312						4,15
142	3,991						3,871
143							2,886
144							4,419
145							3,319
146							3,021
147							3,29
148							3,322
149							3,042
150							3,15



**Norges miljø- og biovitenskapelige universitet**  
Noregs miljø- og biovitenskapelige universitet  
Norwegian University of Life Sciences

Postboks 5003  
NO-1432 Ås  
Norway