

# PROTEIN EVALUATION OF DOG FOOD USING MINK (NEOVISON VISON) AS A MODEL FOR ILEAL PROTEIN DIGESTIBILITY IN DOGS (CANIS FAMILIARIS)



**ABUDURASAK IGE BADINA**

NORWEGIAN UNIVERSITY OF LIFE SCIENCES  
DEPARTMENT OF ANIMAL AND AQUACULTURAL SCIENCES  
MASTER OF SCIENCE THESIS CREDITS 30 P FEBRUARY 2012





**Protein evaluation of dog food using mink (*Neovison vison*)  
as a model for ileal protein digestibility in dogs (*Canis  
familiaris*).**

**SUBMITTED BY**

**ABUDURASAK IGE BADINA**

**ON PARTIAL FULFILMENT OF  
THE DEGREE OF MASTERS OF SCIENCE (MSC)  
IN FEED MANUFACTURING TECHNOLOGY**

**AT THE DEPARTMENT OF ANIMAL AND  
AQUACULTURAL SCIENCES, NORWEGIAN  
UNIVERSITY OF LIFE SCIENCES ÅS, NORWAY.  
FEBRUARY 2012.**

## **Preface**

The project work was done with an opportunity offered to me by my supervisor Ass. Professor Øystein Ahlstrøm, whom I will like to offer a thousand thanks. He saw my enthusiasm and offered me a lending hand. Your patient and willingness to help even when you were very busy made this project to be completed in time. I am also grateful for the help I received during my studies in the department from Professor Trond Storebakken, Marit Ensby, Retired Professor Anders Skrede (who helped me dig out some published papers from old archive), Thea Morken (for published papers on extrusion), and Ass. Professor Mette Sørensen (who encourage me and offered me good advice and referred me to scientific group on my competencies, I am grateful to you). Many thanks to the staff at the Centre for Feed technology Research, FORTEK, for their practical experience and patient with students.

I will also like to offer thanks to several people at the International Belivers Fellowship in Ås and Overcomers Chapel in Trondheim for their prayers and encouragement especially to Mats Jacobsen, Jørn-Erik Mørne (The Evangelist), Henrietta Samuelsen, The bible study group at Utveien, Uduak Mme Family and Gbadamosi Family. Without the help of my family Aderonke, my lovely wife and two children Mercy and Victory who endured my absence from home and offered themselves in prayers and their encouragement I may not have complete the program. You are indeed very special. The appreciation will not be complete without giving thanks to Lord of Lords, King of Kings, and The Almighty God who sent His son Jesus to die on the cross to die for humanity and save a soul like me. The Lord who answers prayers and who is above all. I am saying thank you.

Ås, 25 February 2012.

Badina A.I.

## Abstract

Dog owners pay lot of attention on providing proper nutrition to their dog that will support longevity and good health. Great effort is therefore made by feed producers concerning information about nutritional quality of dog food ingredients and at to what extent they cover the nutritional requirement of dogs at different life stages. Protein and amino acid content and utilization is of great importance in the evaluation of pet food ingredients. A key factor in protein utilization is digestibility. In dogs digestion and absorption in the small intestine will be the main site for evaluating digestibility since 90 % of digestion take place in this part of the digestive tract. Ileal digestibility values will therefore be more correct than apparent total tract digestibility values that are influenced by degradation of protein in the colon. Degraded and metabolized protein from fermentation processes in the colon is not absorbed and utilized as amino acids in the small intestine. Microbial degradation produces volatile N compounds that will not be accounted for and therefore total tract digestibility values will overestimate protein digestibility. Ileal protein digestibility values require use of ileal cannulated dogs, which is an invasive method with ethical considerations. A non-invasive alternative to obtain ileal digestibility values would be to apply the mink (*Neovison vison*), a well established model animal in protein digestibility studies. Mink have been proposed to have a similar total tract digestive capacity as ileal digestion in the dog because of its much simpler digestive tract without caecum, rapid passage rate and low microbial activity in colon. The main objective of experimental part of this thesis was therefore to report a study comparing apparent total tract, colon and ileal digestibility of protein in dog with total tract digestibility in mink using three different protein sources applied in extruded dog food. Lamb meal, poultry meal and fishmeal was applied as main protein sources because of the expected gap in protein digestibility, lowest for lamb meal, intermediate for poultry meal and highest for fish meal. The results showed that overall apparent total tract values were significantly higher than values obtained from colon, ileum or as apparent total tract in mink. Values for apparent total tract, colon, ileum, and total tract in mink were 83.5, 78.5, 74.4 and 77.8%, respectively. Mink digestibility values were significantly different from ileal values but not from colon values. As expected the digestibility was generally lowest for the lamb meal food, intermediate for the poultry meal and highest for fish meal. The difference between total tract digestibility values and ileal values in the dog increased with decreasing digestibility. For the fish meal food the difference was 6.9 % while corresponding for the poultry meal and lamb

meal food was 9.0 % and 11.4 %, respectively. This demonstrates the effect of fermentation and more important, that apparent total tract values overestimate poor digestible protein sources more than highly digestible. Even though mink digestibility values were higher than ileal values in the dog, they were generally closer to ileal values than apparent total tract values for the dog, and they appeared to be closer to ileal values with lower digestibility. Mink digestibility values were similar to values from colon, thus indicating that mink total tract digestibility can be ranked between apparent total tract and ileal in the dog. All methods were highly positively correlated showing coefficients from 0.857 to 0.959 ( $P < 0.001$ ).

Based on this result one can conclude that mink digestibility values for crude protein are lower than total tract and higher ileal values in dogs, but generally closer to ileal values when protein digestibility is poor. This observation strongly indicates that mink protein digestibility is an appropriate model for assessment of ileal protein digestibility in the dog. Overall the study confirms that protein digestibility values in mink are positively correlated to those obtained in total tract, ileum and colon in the dog. To achieve more precise information on mink digestibility as a model in the area amino acid digestibility values should be compared with ileal values in dogs.

## Sammendrag

Hundeeiere er opptatt av å gi hunden et optimalt fôr i forhold til som gir god helse og lang levealder. Fôrprodusentene bruker også mye ressurser for å undersøke næringsinnhold fôrråvarer og i hvilken grad de dekker næringsbehov til hunder i ulike livsfaser. Protein og aminosyre innhold og utnyttelse har størst betydning i evalueringen av proteinråvarer. Fordøyelighet er et viktig mål i for proteinutnyttelsen fra råvaren. Hos hunder er det fordøyelsen og absorpsjonen i tynntarmen som er viktig for måling av proteinutnyttelsen siden 90 % av proteinfordøyelsen skjer i den delen av fordøyelseskanalen. Ileal fordøyelighetsverdier gir derfor det beste målet sammenlignet med total apparent fordøyelighet (fecal) som vil være påvirket av proteinnedbrytingen og omdanningen som skjer i tykktarmen. Nedbrytingen og omdanningen av protein og aminosyrer som skjer i tykktarmen vil produsere nitrogen forbindelser som ikke blir inkludert i fordøyelighetsberegningen av protein, og total apparent proteinfordøyelighet vil derfor overestimere fordøyeligheten av protein i forhold til ileal målinger. Måling av ileal fordøyelighet krever imidlertid at en har tilgang på med ileal-kannulerte hunder som er en etisk betenkelig forsøksmetode. En enklere og mindre krevende metode er å bruke mink (*Neovison vison*), et godt dokumentert modelldyr i forhold til fordøyelighet hos andre arter, som modell for ileal fordøyelighet hos hund. Mink har en total fordøyelighet som trolig kan være lik ileal fordøyelighet hos hund fordi den har en svært enkel fordøyelseskanal uten caecum, rask passasjehastighet og liten mikrobiell aktivitet i colon. Hovedmålet med forsøksdelen i denne masteroppgaven var derfor å vurdere resultatene fra et forsøk hvor en har sammenlignet total apparent fordøyelighet, fordøyelighet målt i colon og ileal fordøyelighet hos hund med total apparent fordøyelighet hos mink. I forsøket ble det brukt tre forskjellige proteinkilder, lammemel, fjørfemel og fiskemel med antatt forskjell i fordøyelighet, høyest for lammemel, middels for fjørfemel og høyest for fiskemel. Totalt sett for alle tre proteinkildene viste resultatene at apparent total fordøyelighet var signifikant høyere enn colon, ileal eller minkfordøyelighetsverdier. Verdiene for apparent total-, colon-, ileal- og minkfordøyelighet viste henholdsvis 83.5, 78.5, 74.4 and 77.8 %. Mink fordøyelighetsverdiene var signifikant høyere enn ileal verdiene hos hund, men var like verdiene fra colon. Som forventet var fordøyeligheten lavest for fôret med lammemelet, middels for fjørfemel og høyest for fiskemel. Forskjellen mellom total apparent fordøyelighet og ileal fordøyelighet økte med synkende fordøyelighet. For fiskemel fôret var forskjellen 6,9 % og tilsvarende for fjørfemel og lammemel var henholdsvis 9,0 og 11,4 %. Disse

forskjellene viser effekten av fermenteringen som skjer i tykktarmen og dessuten at apparent total fordøyelighet overvurderer proteinråvarer med lav fordøyelighet mer enn proteinråvarer med høy fordøyelighet. Selv om minkfordøyelighetsverdiene var høyere enn de ileale hos hund, var de mer like de ileale i tallverdi enn de total apparente, og forskjellen ble mindre til de ileale verdiene med synkende fordøyelighet. I forhold til fordøyelighetsmålinger i colon var minkfordøyeligheten relativt lik slik at man kan si at minkfordøyelighet plasserer seg mellom total apparent fordøyelighet og ileal hos hund. Alle metodene for å måle fordøyelighet var positivt korrelert og hadde koeffisienter fra 0,857 til 0,959 ( $P < 0,05$ ).

Basert på resultatene kan en konkludere med at mink fordøyelighetsverdier er lavere enn total apparente og høyere ileale verdier hos hund, men generelt vil de være mer like ileale når proteinfordøyeligheten er redusert. Dette tyder på at mink fordøyelighet er en god modell for ileal fordøyelighetsmåling hos hund. Generelt viste forsøket også at minkfordøyelighet er positivt korrelert med total apparent-, colon- og ileal fordøyelighet hos hund. For videre vurdering av mink som modell på dette området bør også aminosyrefordøyelighetsverdier hos mink sammenlignes med ileale hos hund.



# Table of contents

I. General part.....	2
Introduction.....	2
Dog food.....	2
Nutrient recommendation for dogs .....	4
Natural diet for dogs.....	4
The digestive tract of the dog and digestion .....	5
Mouth and oesophagus.....	6
Stomach.....	7
Small intestine.....	7
Large intestine.....	8
Protein and amino acid requirement for dogs .....	8
Amino acids.....	8
Protein sources in dog food.....	10
Animal protein sources.....	11
Vegetable proteins sources.....	14
Other Protein Sources.....	17
Dry pet food .....	17
Extruded dog food.....	19
Pre process-conditioning.....	20
Extruder barrel.....	21
Effects of extrusion process on nutritional quality.....	22
Protein evaluation.....	24
Protein digestibility measurement in dogs .....	25
Measuring digestibility.....	25
Apparent digestibility in comparison with true digestibility.....	26
Total tract digestibility in comparison with ileal digestibility .....	27
II. Experimental part.....	30
Aim.....	30
Mink as a model animal .....	30
Materials and methods .....	31
Protein sources .....	31
Chemical analyses .....	31
Processing.....	31
Mink digestibility measurement.....	33
Dog digestibility measurement.....	34
Statistics .....	35
Result.....	36
Food production .....	36
Digestibility experiment.....	36
Correlations .....	39
Discussion .....	39
Apparent total tract digestibility of protein in dog and mink.....	39
Colon digestibility values.....	41
Ileal digestibility in dogs compared with apparent total tract digestibility in mink.....	43
References .....	44

## **I. General part**

### **Introduction**

#### **Dog food**

Dogs play an important role in modern people's life, mainly as a companion animal but also as a working partner. Human-dog relationships have been shown to give beneficial effects on human health. A consequence of this extraordinary companionship with dogs is that every dog owner shown great attention to good care of the dog including nutrition. Provision of proper nutrition is a great concern for dog owners and majority of pet owners choose to feed their dogs commercially prepared pet foods. Adequate and specific nutrients which will supply longevity, health and good quality of life are the desire of every pet owner. This in conjunction with palatability and nutrient digestibility is of great importance in dog food formulation (Halpin et al, 2001). Even though great effort is made concerning information about nutritional quality of dog by the manufacturers, however information on the digestibility of component ingredients used may be limited. Protein utilization is of great importance in the use of available pet food ingredients. Protein utilization is made possible through the ability of the dog to digest component amino acids of the diet. Therefore ability to accurately measure the digestibility of protein accurately with a precise method is important in economical formulation of diets for dogs. This is also important for optimal use of feed proteins as these varies among animals. Because the use of different protein sources to supply required protein and amino acids are not far fetch in the manufacturing of dog food leading to different digestibility profile. This knowledge gap needs to be filled which is one of the objectives of this work especially with known or commonly use ingredients.

Finished dog food products that are in stores are grouped into different categories; dry foods, wet foods (canned), semi moist and extruded treats (otherwise known as snacks). While other types have their advantage and purpose, dry foods is by far the largest income generation and constitute the highest output of all pet food produce (Tran, 2008). Classification of pet food is based on processing method, preservation method and moisture content (Case et al, 2011).

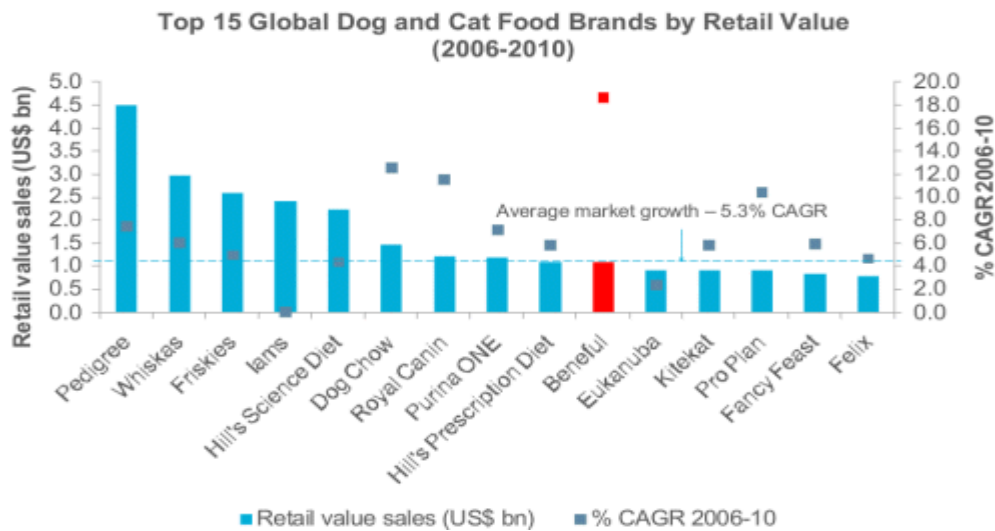

**Figure 1 : Top global dog and cat Food brands by retail value**

Source : <http://www.meriden.com.cn/Simplified/NewsView.asp?ID=692&SortID=25>

Figure 1 show the top global brand in dog and cat food between the year 2006 and 2010. The figure shows in US \$ billion the average revenue of these brands, confirming how huge the pet food industry is in terms of retail value sales. The top brands are pedigree, followed by Whiskas, Friskies and Iams to mention but few. The figure that followed below (Figure 2) shows that the biggest company having a market share (according to the graph) is Mars incorporated with about 25% followed by Nestle with almost the same value of about 23% and others like Procter & gamble and Colgate shares the remaining.

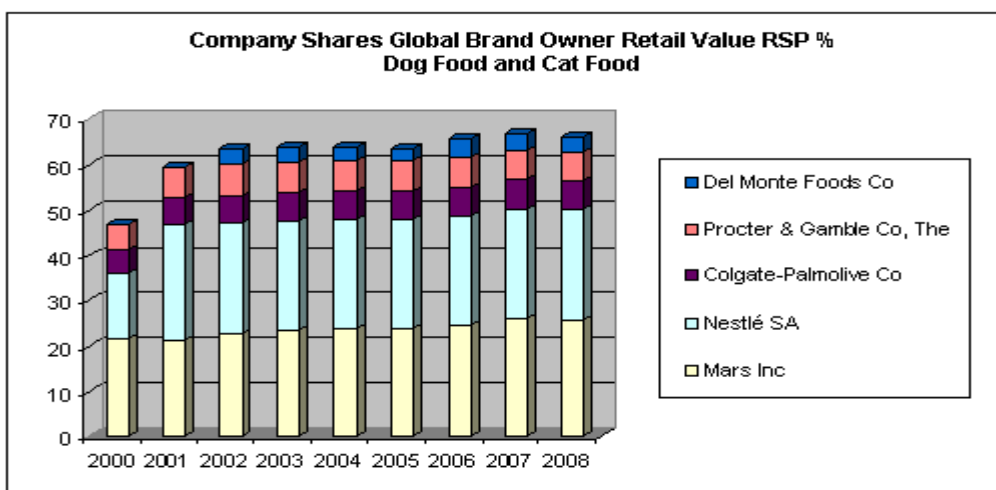

**Figure 2 : Market share of the top producers of dog and cat food**

Source : <http://www.ats.agr.gc.ca/inter/5504-eng.htm>

## Nutrient recommendation for dogs

The manufacturers of pet food use information about nutrient requirement to formulate balanced and complete pet food for different stages of dog lives. This is due to the fact that various ingredients from various sources are combined to make this food and of which its quality must be a top priority and its ability to fulfil required nutritional needs of the dog. The aim of these manufacturers is to provide food that gives normal growth, promotes high quality performance and longevity, vitality with long term good health (Case et al, 2011).

The nutritional requirements to maintain good health is compulsory while requirements for energy and specific nutrients changes during the life of dogs. These can increase during growth, reproduction and physical work such as sports while it will reduce when adulthood is attained. Published general guidelines for nutritional requirement are used. One is published by the National Research Council (NRC) in U.S.A. with latest publication in the year 2006. This was collated by ad hoc committee of companion animal nutritionist in 2000. It provides nutrients estimates for pets. The other one is from the association of American Feed Control Officials (AAFCO) containing nutrient profiles for dogs first published in 1990. The publication recommends minimum and maximum levels of nutrients that are included in commercial pet foods at the time of feeding (Case et al, 2011).

## Natural diet for dogs

Dogs (*Canis familiaris*) are from the taxonomical order *Carnivora*. Carnivores are considered to be meat eaters and the natural diet of the wolf (*Canis lupus*) which is the ancestral species of the dog, is based on large prey such as elk, caribou, deer and smaller prey such as hare and mice (NRC, 2006). Other canids (some bears) can have vegetable sources as their main diet such as berries, fruits and parts of plants indicating that they partly rely on a vegetable diet and not strictly consume meat. The physical form of the digestive system, from the teeth to the length and various compartments of the digestive tract will reveal if the animal rely on vegetable food sources or animal sources. A typical characteristic of the digestive system of carnivores is a short digestive tract and rapid passage rate that reflects their adaptation to feed sources with high digestibility such as animal protein and fat. Dogs have an unsacculated colon, a small caecum and a quick passage rate of food through the intestinal wall; a character that ensures their suitability to diets high in energy density and digestibility (Case et al, 2011). This intestinal character has made extensive microbial fermentation in the gastro-intestinal tracts of dogs to be of limited activity.

Under human care, dogs have adapted to be more omnivorous with diet type containing considerable amount of carbohydrates, mainly from grain (Case et al, 2011). The selection of potential diet for them provided by humans is also based on the appearance, odour, flavour and texture even their taste system is considered to be of a carnivore pattern (Bradshaw, 2006). In comparison to many herbivorous that thoroughly chew their food, dogs often swallow large boluses of food with little or no chewing. The arrangement of their dentition is associated with an increased capacity to chew and crush food and also of more omnivorous in diet, a typical of the pattern seen in most obligate carnivores. Dogs are also sensitive to the taste of amino acids and various types of organic acids and also show preference for sweet foods (Case et al, 2011).

## **The digestive tract of the dog and digestion**

Dogs are endowed with a monogastric gastrointestinal tract (Figure 3). The dog intestinal tracts are: mouth, oesophagus, stomach, small intestine, and large intestine leading to the anus accordingly. Dogs with a body length of 0.75m, have an intestinal length averaging 4.5m with small intestine as long as 3.9m and large intestine is 0.6m long (NRC, 2006). This is characterised with rapid passage rate and adapted to diets with high energy density and high digestibility helped by simple stomach, non-sacculated, non-voluminous colon (Smeets-peeters et al, 1998) and a large absorptive surface in the digestive tracts that serves to increase the rate of nutrient digestion aided by the presence of villi (NRC, 2006). Dogs have a short and relatively simple large intestine and most of the digestive processes and the absorption of nutrients take place in the small intestine.

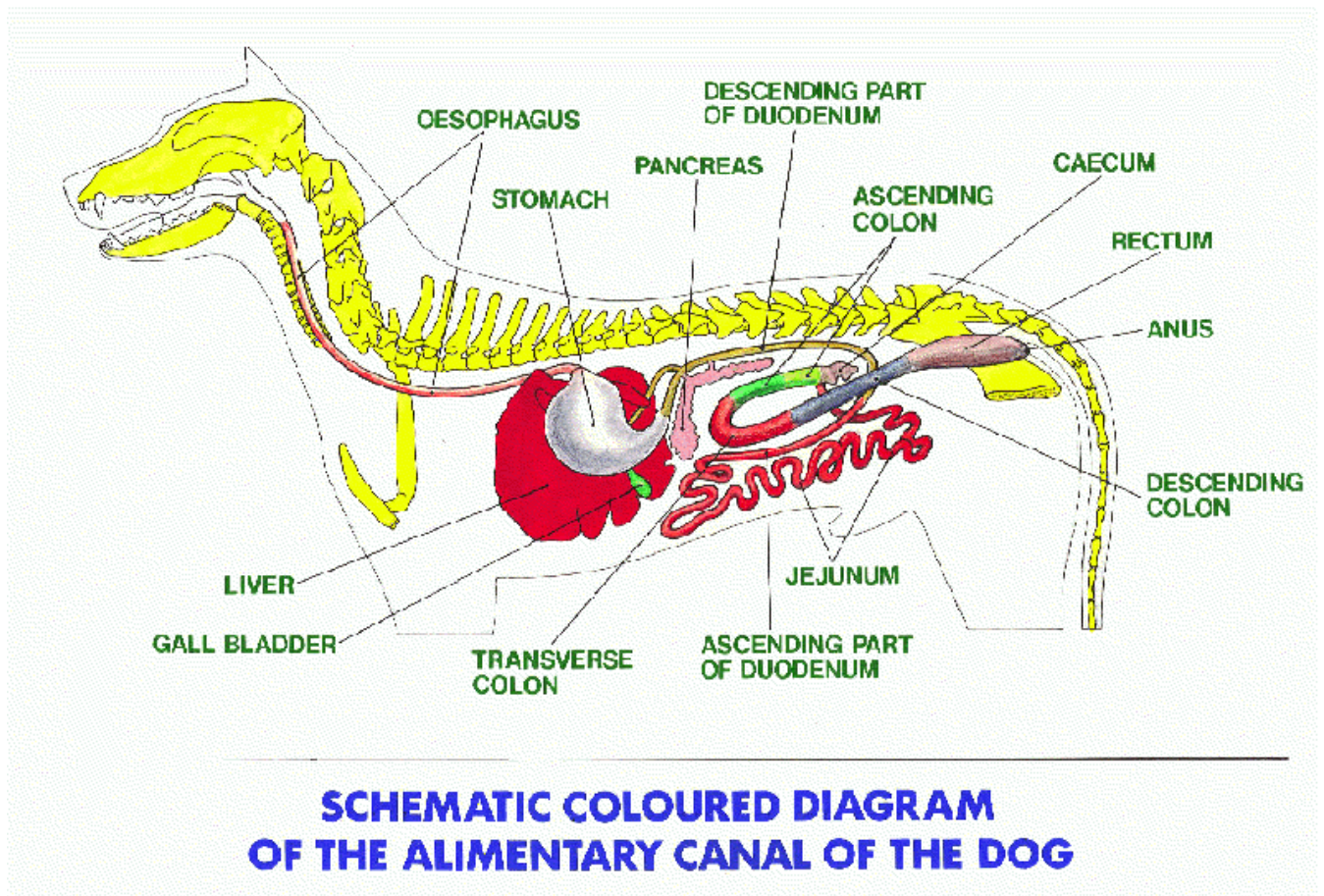

### SCHEMATIC COLOURED DIAGRAM OF THE ALIMENTARY CANAL OF THE DOG

**Figure 3: Digestive tract of dog**

(Source: [www.ucd.ie/vetanat/images/43.gif](http://www.ucd.ie/vetanat/images/43.gif))

#### Mouth and oesophagus

With the aid of the salivary glands, pancreas, liver, and gallbladder, dogs are able to break down the huge nutrients contain in the food into simple forms that the body can absorb and utilize. The mouth is where digestion starts as it contains well suited sets of teeth for meat eating such as cutting, chewing and crushing of solid food including bones. Secretion of saliva also occurs in the mouth at the site of potential food or the smell of its odour. Dogs lack the  $\alpha$ -amylase in its saliva; this is reflected in the eating behaviour of dogs, which tend to bolt all but the toughest foods. The amylase activity is in the pancreas secretions acting on the food on getting to the stomach and it increases with diets supplements with wheat bran (Smeets-peeters et al, 1998). The food after swallowing and mechanical treatment moves through the oesophagus to the stomach with the aid of the relaxing cardiac sphincter which

closes almost immediately to prevent regurgitation of the stomach content into the mouth through the oesophagus.

## Stomach

The stomach is both a storage organ and a mixing bag for the food and enzymes action and also controls the flow rate of chyme to the small intestine. The stomach proximal section is capable of expansion to allow storage of meals, allowing consumption of discrete meals rather than many small meals, which is of great importance to dogs as they are meal feeders (NRC, 2006; Case et al, 2011). The stomach secretes gastric lipase (partly digesting fats and hydrolyzing triglycerides into fatty acids and glycerol), pepsin (which begins digestion of proteins into smaller polypeptides), hydrochloric acid and some mucus which lubricates and protects the stomach wall. The process results in a semi-fluid mass of partly digested food known as chyme. The process is regulated by hormones and nerves in the brain. The chyme is propelled into and through the small intestine mainly by the direction of propagation of the small intestinal pacesetter potentials. These movements are regulated via structure and physiological properties of the digestive tract as well as the physical and nutritional characteristics of the diet (Smeets-Peeters et al, 1998).

## Small intestine

The chyme passes into the duodenum the first part of the small intestine. The small intestine is the primary site for digestion and absorption of nutrients. It consists of duodenum responsible for digestion and is followed by jejunum and ileum that ensures the absorption of nutrients. Within the walls of the small intestine and from pancreas enzymes are secreted to digest carbohydrates, fats, and proteins. Pancreas also secretes pancreatic juice, made up of sodium bicarbonate. Its function is to neutralize the acidic chyme arriving in the duodenum, giving an alkaline environment for proper functioning of enzymes from both pancreas and the small intestinal. These enzymes consist of protease which is involved in protein digestion, amylase and lipase for carbohydrate and fat digestion respectively. Pancreas also secretes the hormone insulin giving control of blood sugar in the blood stream. Bile salts are produce by the liver and stored in the gall bladder. They are secreted into the gut through a bile duct when the need arise. The bile salt acts on the fat converting them into tiny globules which is process by the lipase enzyme from the pancreas. The fat is transferred to the blood stream but firstly absorbed into the lymph vessels before then. The nutrients produced after completion of the digestion are absorbed through the villi of the intestinal wall into the blood stream for onward

journey to the tissues of the body while the end products will be metabolized in the liver (McDonald et al, 2011).

### Large intestine

The remaining food content from the small intestine after almost all the nutrients have been absorbed passes through the ileocecal valve into the large intestine. The main function of the large intestine is to absorb the water and certain electrolytes such as sodium in the food (Case et al, 2011) as well as bacterial digestion of dietary fibre. The large intestines consist of caecum, colon and rectum. The caecum and colon are engaged in bacterial fermentation of the unabsorbed nutrients with the presence of a large bacterial population, which transform the nutrients to short chain fatty acid, some vitamins and various gases. The undigested food, water, sloughed cells, digestive secretions, and bacteria altogether forming faeces then passes into the rectum and is excreted through the anal canal. ). Intestinal length is a factor that influences the amount of time food resides in the gut, which also influences the duration of digestion. Dogs with a body length of 0.75m, have an intestinal length averaging 4.5m with small intestine as long as 3.9m and large intestine is 0.6m long (NRC, 2006). This is characterised with rapid passage rate and adapted to diets with high energy density and high digestibility helped by simple stomach, non-sacculated, non-voluminous colon (Smeets-peeters, et al, 1998) and a large absorptive surface in the digestive tracts that serves to increase the rate of nutrient digestion aided by the presence of villi (NRC, 2006). Carnivores such as foxes and dogs have a short and relatively simple large intestine and most of the digestive processes and the absorption of nutrients take place in the small intestine.

## **Protein and amino acid requirement for dogs**

### Amino acids

Protein are made up of both essential and non-essential amino acids that helps in the build up of muscle, use for energy and needed for metabolic function of the body. The quality of protein required by a dog is age dependent (Dust et al, 2005) with growing dogs requiring more while adult dogs require less (Case et al, 2011). This is due to the fact that puppy is growing rapidly with large amount of muscle being deposited in its body thus, needs for its demand for protein which is in contrast to the protein need of adult dog (Dust et al, 2005).



Protein deficiency may result in lower or non-consumption of food by dogs. A weight loss due to depletion of protein reserve and eventual death may also occur. A diet containing protein sources that are of high quality and also serves as the source of essential amino acid is required for dog food. This may not always be the case leading to disparity or differences in the value of the metabolizable energy (ME) of the protein. A high quality protein source with higher digestibility value will result in lower protein requirement estimates and vice versa in the case of low quality protein source included in dog diet. The need for dietary protein for dogs is based on the facts that the animal cannot make the essential amino acids use for many proteins activities in the body such as maintenance, growth, gestation and lactation. They are also responsible for the production of other life essential biological active compounds (NRC, 2006).

The table (table 1) below summarizes the protein requirements at different stages of growth and also the essential amino acid requirements as published in the NRC report for 2006. It should be noted that the protein requirement for growing dogs is higher than that of adult dogs (Case et al, 2011) and it's more than double of the requirement for adult dogs. However it gets lower as the puppy ages. It is also recommend that lactating bitches should receive more protein to compensate for milk outlet and stress during this period.

**Table 1: Protein requirements and recommendation allowance for dogs at different stages (NRC, 2006)**

	<b>Requirement g/Mcal (4.2MJ)</b>	<b>Recommended allowance g/Mcal (4.2MJ)</b>
<b>Adult</b>	<b>20</b>	<b>25</b>
<b>Puppy 4-14 weeks</b>	<b>45</b>	<b>56.3</b>
<b>Puppy &gt;14 weeks</b>	<b>35</b>	<b>43.8</b>
<b>Late gestation, Lactation</b>	<b>?</b>	<b>50</b>

Ten amino acids (table 2) are essential to the dogs and these are listed as; arginine, histidine, Isoleucine, leucine, lysine, methionine, phenylalanine, threonine, tryptophan and valine (NRC, 2006).

**Table 2: Amino acid requirements for growing dogs and for maintenance in adult dogs****(NRC, 2006)**

<b>Amino acid requirement</b>	<b>Growing dogs after weaning (in g/Mcal ME)</b>	<b>Maintenance (in g/Mcal ME)</b>
<b>Arginine</b>	<b>1.33</b>	<b>0.70</b>
<b>Histidine</b>	<b>0.50</b>	<b>0.37</b>
<b>Isoleucine</b>	<b>1.00</b>	<b>0.75</b>
<b>Methionine</b>	<b>0.53</b>	<b>0.65</b>
<b>Leucine</b>	<b>1.63</b>	<b>1.35</b>
<b>Lysine</b>	<b>1.40</b>	<b>0.70</b>
<b>Phenylalanine</b>	<b>1.00</b>	<b>0.90</b>
<b>Threonine</b>	<b>1.25</b>	<b>0.85</b>
<b>Tryptophane</b>	<b>0.35</b>	<b>0.28</b>
<b>Valine</b>	<b>1.13</b>	<b>0.98</b>

The essential amino acids that are of special concern in dog food are arginine, lysine, and the sulphur containing amino acids; methionine and cysteine. Arginine is essential throughout the life span of dogs for normal protein synthesis and as an important part of the urea cycle. It functions as an ornithine and urea precursor and its deficiency in the diet can lead to metabolic deficiencies (Case et al, 2011). Lysine is a precursor of other constituents such as hydroxylysine and is involve with collagen cross-linkages (NRC, 2006). Due to reactive nature of lysine during heat treatment of dog food, its deficiency can be severe and this can make the growing dog dietary requirement to increase as the protein level increases in the diet. Lysine and tryptophan are the limiting amino acids in cereal source of protein in dog food, while sufficient quantity are in meat proteins so inclusion of it with control processing method is highly recommended in pet food (Case et al, 2011). The sulphur amino acids methionine can supply the indispensable cysteine through its ability to synthesize cysteine in the body. It is the most limiting amino acids in diet formulated using natural ingredients i.e. animal and plant protein source (NRC, 2006; Case et al, 2011). Since it is involve in the donation of methyl group, a deficiency in methionine can result in several metabolic changes/disturbances such as cell replication interference and synthesis of phospholipids. Cysteine is a constituent of hair and glutathione (NRC, 2006). Its involvement in secondary structure of proteins is also noted (NRC, 2006).

## **Protein sources in dog food**

Protein source is a major component in pet food (Dust et al, 2005). Sources of protein for pet foods comes from various avenue, which may include majorly animal sources, plants sources

(such as grains) and sometimes the combination of both animal and plant sources (Case et al, 2011). Other proteins sources that are in use or may be in use soon are bacteria protein meal and krill meal from crustaceans. The protein and amino acid supply in dogs are dependent on the amount of protein in the diet, the amino acid composition of this protein and the digestibility of the individual amino acids. In the production of commercial dog food, different protein sources are included to supply the required amount of protein and essential amino acids, examples of which includes: poultry meal, fish meal, meat meal and soybean meal. The quality of the protein sources used may vary considerably, due to different amino acid composition and digestibility. The pet food industries usually make use of different protein sources such as meat meals, poultry meals, poultry by-product meals and soybean meal and though alternative protein sources are being studied but only to a limited extent in companion animals (Folador et al, 2006). It is believe that consistency in quality of protein is found much more in plant protein source than in animal protein source, even though its availability may be lowered than in high quality animal sources. However, high quality animal source protein supplies superior amino acid balances in pet food (Case et al, 2011). The protein sources which supply the required amino acid use in enhancing the immune statues of dogs also serve as a palatants in their diet (Dust et al, 2005).

### **Animal protein sources**

The pet food companies' animal protein source includes meat meal, bone meal, poultry meal, poultry by-product meals (Dust et al, 2005). The list also includes lamb, lamb meal, spray dried egg, fish, and fish meal (Case et al, 2011). Included also are by-products meals source from slaughter houses. These rendered animal by-product meals, such as meat and bone with poultry meal together are utilized in great quantities in companion animal diets (Cramer et al, 2007) and are major contributor to the growth and expansion of the world's pet food industry (Murray et al, 1997). The huge fish waste generated from fish processing are also utilized in pet food as protein sources to enhance palatability (Folador et al, 2006).

#### **Raw meat**

Meat is described in this context as a representative of slaughtered mammal including striated muscle of pork, beef or sheep. The use of poultry in this context includes flesh and skin of domestic poultry. By products includes apart from the main ingredients such as fish, poultry and meat; those ingredients not used as human foods such as hair, feathers, hooves, horn,

intestines, blood, organ meats etc., naturally occurring in raw animal materials which are included in varying levels (Case et al, 2001; Murray et al, 1997). Ingredients use may mean two words i.e. “poultry” includes the clean combination of flesh and skin with without bone derived from part or whole carcasses of poultry exclusive of feathers, heads, feet and entails. “Poultry by-product” refers to the clean parts of carcasses of slaughtered poultry including the bone, heads, feet and intestines.

### Animal Meal

The word “meal” as included in pet food ingredients is any material that has been ground or otherwise reduced in particle size. The term when use in the context of chicken meal is the dry, ground, whole chicken exclusive of heads, feet, viscera or feathers and “chicken by-product meal” is the same processing method, but may include by-products (Case et al, 2011).

The nutritional quality of animal protein sources is constantly changing (Murray et al, 1997). These could depend on the supplier and the type of refining process that the pet food manufacturer uses. These also affects its digestibility and two of the primary factors believed to affect amino acid digestibility of animal meals are ash content and processing temperature (Johnson et al, 1997). In the latter study it was found that the availability of amino acid in meat bone meal decreased when processing temperature increased from 116 to 160<sup>0</sup>C and the availability of lysine meat bone meal used for chick diet was decreased from 85 to 35% when the processing temperature increased from 125 to 150<sup>0</sup>C.

Another example is the varying amounts of bone in meat protein sources which affects its quality as a protein source as well as the mineral balance of the entire diet. Bone matrix is made up of protein known as collagen, a poorly digested protein in pet food. All muscle meats are very low in calcium content and have calcium: phosphorous ratios between 1:15 and 1:26. The inclusion of bone with meat as an ingredient will though normalize the calcium: phosphorous ratio but it will gear-up the amount of calcium, thus creating an imbalance in mineral content if inexpensive meat and bone meals containing excess levels of minerals are use in pet food production. The form of the protein source and the degree of processing also states a lot about level of protein content. An example is the different states of protein ingredients i.e. meal, whole source such as chicken and by-product, which differs in protein

content and quality. Whole chicken as an example, which after processing contains high moisture content and fat with very little protein, while the chicken meals through its cooking processing remove a high proportion of fat which when included in pet foods may be the principal protein source due to their low moisture content and fat content will have higher protein and digestibility than their typical feed grade source.

The by-product meal refers to the meal produced from rendering and drying of an animal by-product protein source. The inclusion of feet and head during the processing reduces protein quality and digestibility of the end product. These same relationships and definitions apply to meat, meat meal and meat by-product and other animal source proteins such as lamb or fish (Case et al, 2011). The variation in protein quality among these different protein sources is of great concern in commercial dog foods (Johnson et al, 1997). Table 3, shows the analysis of essential amino acid content of some plant protein source use in dog food. This confirms the needs to mix up ingredients as some of this protein source are limiting in some essential amino acids which are needed in the feed. The use of animal source protein in the component of a home-made diet or treat/supplement in pet food is also of concern as it is known that it is a growing sector of the pet food market. These products include raw food diets, organic foods, and rations that are promoted as “all natural” or holistic. The most commonly feed animal source protein ingredients that owners report feeding to their dogs are beef and poultry. These are purchased frozen from different sources (Case et al, 2011). Other animal sources proteins that are fed to dogs are freeze- dried liver or salmon. They are highly palatable to most pets (Baskot, 2004) and can be used as potent primary reinforces in training. However they are not nutritionally balanced and so should not be more than 5% of pet’s nutritional intake (Case et al, 2011).

### Marine Sources

Antarctic krill (*Euphausia superba*) can also be a good source of protein for extruded dog diet. It contains on a dry matter basis, protein from 60-75% and fat content of 10-20% (Ovrum Hansen et al, 2009). But its processing with extrusion if not well manage can create a problem. This is because of its high fat content which may lubricate extrudate, resulting in low torque and low pressure during cooking. Krill also contains a high fluoride and copper level above the EU restricted point. But if krill is partially de-shelled before processing, the fluoride level will be reduce since it is mainly located in its exoskeleton (Hansen et al, 2010). It is possible that better growth performance and nutrient digestibility will result in using krill

as a protein source in dog food because these were observed in its use for feeding fish (Suontama et al, 2007) but care should be taking that they do not lower the quality of the final product.

**Table 3: Analysis of some animal protein source use in dog food (Ahlstrom O. et al, 2004 ; Vhile, et al, 2005b; Edison Serrano, 2011)**

<b>Composition,</b>	<b>Fishmeal LT</b>	<b>Feather meal</b>	<b>Meat &amp; bone meal</b>	<b>Lambmeal (meatmeal)</b>	<b>Poultry meal</b>	<b>Bloodmeal</b>
<b>As g kg<sup>-1</sup></b>						
<b>Dry matter</b>	<b>930</b>	<b>893</b>	<b>958</b>	<b>986</b>	<b>939</b>	<b>-</b>
<b>Crude protein</b>	<b>710</b>	<b>776</b>	<b>524</b>	<b>567</b>	<b>599</b>	<b>-</b>
<b>Crude fat</b>	<b>86</b>	<b>119</b>	<b>183</b>	<b>123</b>	<b>159</b>	<b>-</b>
<b>Ash</b>	<b>150</b>	<b>20</b>	<b>220</b>	<b>293</b>	<b>166</b>	<b>-</b>
<b>As g 16g N<sup>-1</sup></b>						
<b>Arginine</b>	<b>5.5</b>	<b>6.1</b>	<b>6.7</b>	<b>6.4</b>	<b>6.6</b>	<b>4.7</b>
<b>Histidine</b>	<b>2.5</b>	<b>0.8</b>	<b>2.2</b>	<b>3.4</b>	<b>1.5</b>	<b>7.8</b>
<b>Isoleucine</b>	<b>4.5</b>	<b>4.8</b>	<b>3.3</b>	<b>4.2</b>	<b>3.5</b>	<b>1.3</b>
<b>Leucine</b>	<b>7.5</b>	<b>8.7</b>	<b>6.7</b>	<b>7.7</b>	<b>6.2</b>	<b>13.4</b>
<b>Lysine</b>	<b>7.6</b>	<b>2.3</b>	<b>5.8</b>	<b>7.7</b>	<b>4.9</b>	<b>9.2</b>
<b>Methionine</b>	<b>3.0</b>	<b>0.7</b>	<b>1.5</b>	<b>2.1</b>	<b>1.6</b>	<b>0.9</b>
<b>Phenylalanine</b>	<b>3.7</b>	<b>4.8</b>	<b>3.7</b>	<b>4.2</b>	<b>3.6</b>	<b>7.8</b>
<b>Threonine</b>	<b>4.4</b>	<b>4.9</b>	<b>3.6</b>	<b>4.0</b>	<b>3.6</b>	<b>3.9</b>
<b>Tryptophan</b>	<b>1.2</b>	<b>0.5</b>	<b>1.1</b>	<b>2.8</b>	<b>2.6</b>	<b>0.4</b>
<b>Valine</b>	<b>5.4</b>	<b>4.7</b>	<b>4.9</b>	<b>2.95</b>	<b>4.5</b>	<b>9.6</b>

### **Vegetable proteins sources**

Grain/plant sources of protein used in pet foods include corn gluten meal, various forms of soy (meal, flour and grits), alfalfa meal, flax seed meal and wheat germ. Pet foods that contain grain products as the major source of protein usually include a combination of soy products

and corn gluten meal. Corn gluten meal is the dried residue that remains after most of the starch, fibre and germ-containing portions of the corn grain have been removed. As a protein source, corn gluten meal is relatively consistent in quality, containing approximately 60% protein but its protein is deficient in the essential amino acids; lysine, arginine and tryptophan. Protein source from plant is not as digestible as high quality animal protein ingredients, but its protein is comparable to or more available than some meals and by product meals (Case et al, 2011). Plant protein sources with a low degree of processing are inexpensive and readily available. But their use for pet just like for example carnivorous fish is limited by the presence of starch and structural carbohydrates and a wide variety of anti nutritional factors (Overland et al, 2009). Table 4, shows the analysis of essential amino acid content of some plant protein source use in dog food. This confirms the needs to mix up ingredients as some of these protein sources are limiting in some essential amino acids which are needed in the feed.

Texturized vegetable protein (TVP) containing 50% crude protein is often use in canned and semi moist foods. Produce by extrusion of defatted soy flour, giving a meat like texture and appearance after undergoing the canning process. It possess an advantage of absorbing the flavours of the ingredients with which it is cooked and also giving a bland flavour and aroma. Its digestibility in the small intestine of dogs was found to be lower than that of beef protein, creating an increased and softer faecal volume. The most forms of soy included in dry extruded pet foods are defatted soybean meal and soy flour. Its use in a study to compare the ability of adult dogs to digest soy products to poultry meal that were included in an extruded, dry food found that small intestinal and total tract protein digestibility of the soy product did not differ from each other but were all significantly more digestible than poultry meal. Soy bean meal is also a rich source of lysine which is considered as an advantage as the use of corn gluten meal in commercial pet foods. Soy protein is well digested by dogs but its carbohydrate content which is about 30% in texturized vegetable protein as an example, has a low digestibility in the small intestine. Because of the composition of these carbohydrates, which contains soluble oligosaccharides and polysaccharides, they form an healthy component in the large intestine. This is due to the fermentation action of colon bacteria on it resulting in the production of short chain fatty acids. They are also assumed to reduce postprandial insulin levels with dogs fed texturized vegetable protein diets. It is known that a high level of soy protein (as much as 50% or more) leads to loose stools and flatulence in some dogs though this may not be the case with moderate use in diets (Case et al, 2011).

Soy bean meal contains anti nutritional factors that produce histopathological damage in the gastro-intestinal tract as well as reduce nutrient digestibility and growth performance of carnivorous fish (Overland et al, 2009). These also affect the ability of animals to absorb other nutrients. Example of this anti nutrient factor is trypsin inhibitors which reduce the digestibility of protein in the diet. Another one is phytate which interferes with the absorption of certain minerals. One good thing is that these anti nutritional factors are heat labile and they are mostly destroyed during pet food processing. However phytate effects need to be accounted for in pet food when using soy products because it is not heat labile and has an interference nature with certain minerals (Case et al, 2011).

**Table 4: Analysis of essential amino acid content of some plant protein source use in dog food. (Overland et al, 2009; Edison Serrano, 2011)**

<b>Composition</b>	<b>Soybean Meal</b>	<b>Pea protein concentrate</b>	<b>Rape seed</b>	<b>Wheat gluten</b>
<b>As g kg<sup>-1</sup></b>				
<b>Dry matter</b>	<b>885</b>	<b>904</b>	<b>962</b>	<b>910</b>
<b>Crude protein</b>	<b>486</b>	<b>496</b>	<b>431</b>	<b>938</b>
<b>Crude fat</b>	<b>18</b>	<b>38</b>	<b>22</b>	<b>9</b>
<b>Ash</b>	<b>64</b>	<b>52</b>	<b>86</b>	<b>8</b>
<b>As g 16g N<sup>-1</sup></b>				
<b>Arginine</b>	<b>7.55</b>	<b>8.74</b>	<b>7.43</b>	<b>2.99</b>
<b>Histidine</b>	<b>2.86</b>	<b>2.65</b>	<b>6.03</b>	<b>2.03</b>
<b>Isoleucine</b>	<b>4.92</b>	<b>4.32</b>	<b>0.70</b>	<b>3.09</b>
<b>Leucine</b>	<b>7.61</b>	<b>7.21</b>	<b>5.80</b>	<b>6.18</b>
<b>Lysine</b>	<b>6.07</b>	<b>7.07</b>	<b>9.51</b>	<b>1.39</b>
<b>Methionine</b>	<b>1.36</b>	<b>0.90</b>	<b>6.96</b>	<b>2.03</b>
<b>Phenylalanine</b>	<b>5.08</b>	<b>4.73</b>	<b>6.27</b>	<b>4.58</b>
<b>Threonine</b>	<b>4.01</b>	<b>3.73</b>	<b>3.71</b>	<b>2.35</b>
<b>Valine</b>	<b>5.02</b>	<b>4.66</b>	<b>18.10</b>	<b>3.63</b>



## **Other Protein Sources**

### Single cell protein

Bacteria protein meal is produced by continuous bacteria fermentation using a defined mixture of four different bacteria; *Methylococcus capsulatus* (Bath), *Alcaligenes acidovorans*, *Bacillus brevis* and *Bacillus firmus* and natural gas as the carbon and energy source. It contains 70% crude protein on a dry matter basis with a nutritionally well balanced amino acid composition (Skrede & Ahlstrom, 2002). The final product when spray-dried is a reddish/ brownish meal possessing 95% dry matter, 10% lipids and 7% ash and in comparing with fish meal, it has the same content of methionine and cystine, a higher content of tryptophan and threonine, with a lower content of lysine (Overland et al, 2004).

The use of bacteria protein meal as a protein source in pet food showed that it can compete favourably with other protein source diets with no significant differences in digestibility of protein, fat or carbohydrate. It is well accepted by animals with no sign of health complications and even creates increase marginal improvement of feed conversion (Skrede & Ahlstrom, 2002). Its inclusion may however affect the technical quality of extruded dog diets. These effects include formation of shorter pellets with increased diametric expansion, reduced dust percentage, sinking rate and breaking force. But if feed are process moderately, extruded dog diet can experience increase pellet length and expansion, with decreased fat leakage and sinking rate (Overland et al, 2007).

### **Dry pet food**

Dry pet foods contain 90% or more dry matter (Case et al, 2011); and with the low moisture content and expanded porous nature, there will be opportunity for coating of the food and also optimal shelf-stability during storage and transportation as low moisture content will also prevent microbial development (Tran, 2008).

The main components in the manufacturing of dry pet foods are cereal grains (including cereal grain by-products), meat, poultry, fish, milk products (may be categorise as animal and animal by-products), vegetable fats/oils, vitamin and mineral supplement (both macro and micro elements).

Dry pet foods appear on the store shelf as biscuits, kibbles, pellets, meals and extruded products. Depending on the purpose of the food, the dry matter content of dry foods ranges

from 8 to 22% fat and from 18 to 32% protein. Dry foods have an advantage of being economical to feed than wet and semi-moist food and have a longer shelf life due to low moisture content, if stored properly. They can also be use in preventing plaque on the teeth of pets. Their disadvantage in comparison with wet and semi moist food is their low palatability to dogs due to lower fat content or low quality of ingredients and nutrient availability coupled with low digestibility (Case, et al, 2011).

Extrusion cooking technology is the main manufacturing process for commercially dry pet food due to its flexible approach to product manufacture in comparison to baking and pelleting which are also in use for some dry pet products (Lankhorst et al, 2007). These flexible approach includes ability to sterilize (to eliminate micro-organism thereby creating a safe product), addition of higher fat levels in order to improve palatability (done by spraying/vacuum coating a liquefied fat onto the surface of extruded products), increase nutrient digestibility and availability, achieve a desired density and to form the products in one application (Tran, 2008: Baskot, 2004)

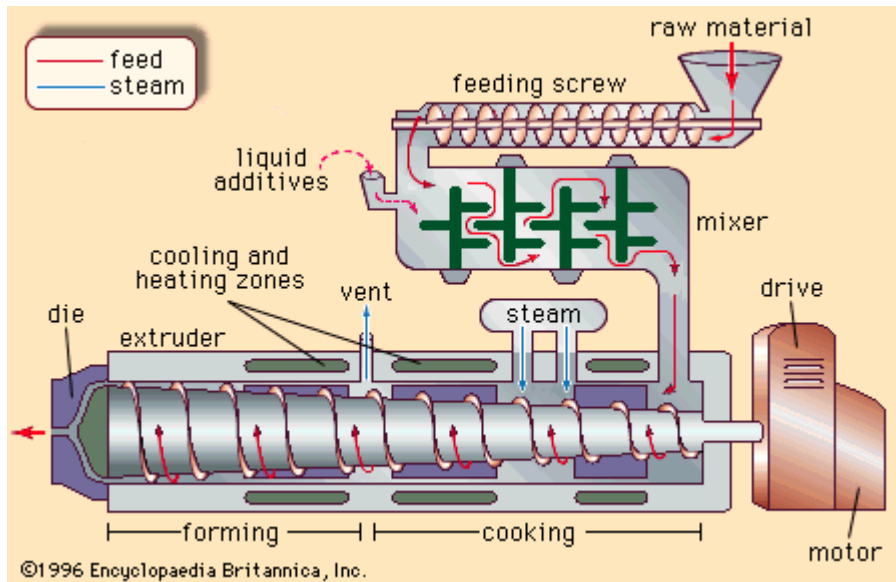

**Figure 4: An extruder**

Source: [www.britannica.com/EBchecked/topic/199193/extruder](http://www.britannica.com/EBchecked/topic/199193/extruder).

Extrusion causes rapid cooking of the starches within the dough, resulting in increased digestibility and palatability, therefore for a proper processing of the product, some level of starch is included in the ingredients. The caloric density of dry pet foods is between 3000-4500 kcal of metabolizable energy (ME)/kilogram (kg) or between 1300 and 2000 kcal/pound (lb) on dry matter basis (DMB). Packaging and processing method used also plays a role in energy density (Case et al, 2011). A few dog foods are baked at high temperatures rather than extruded. The final product is a dense, crunchy material broken into irregular chunks. It is palatable to some extent though it contains no sprayed on fats and other enhancers needed on extruded dry pet food.

### **Extruded dog food**

Extrusion is the commonly way for production of dry dog food. The foods may contain high levels of crude fat with the fat applied by spraying after the extrusion production process. The dog food crude fat content may be up to 5 to 12% and for acceptance by the pet it is coated with various protein digest and flavours (Baskot, 2004). The extrusion makes use of different unit processing operations with mixing, kneading, shaping and forming taking place in the process. Extrusion process produces a product that absorbed more lipids as much as 30-40% as it creates more holes inside the extruded material giving room to the lipids. Thus giving a high energy feed material (Sorensen, 2003). It is a process that makes use of combination of moisture, temperature, pressure and mechanical shear to treat expandable and moistened starch/protein based ingredients. It should also be noted that it is a high temperature short time (HT-ST) cooking process done with the action of the rotating screw enclosed in a chamber known as the extruder barrel. The Raw material that are to be use should have being pre-process i.e. grinding and mixing, and are fed into the feeding system of the extruder (Tran, 2008). The feeder ensures the constant supply of the materials to be extruded into the processing line. The processing gives a viscous dough-like substance because of the action of the rotating screw in the barrel on the fed raw material and it pushes it forward giving the products its characteristics texture. Application of mechanical shear forces and high heating temperature (80 to 200°C) within a short time (10 to 270 seconds) is known with extrusion cooking. This can minimize the detrimental impacts but also maximize the benefits of heat treating the food as in reduction of contaminants (Tran, 2008).

The major types of extruder used in the feed industry are both single and twin screw extruder. While single screw cost less to purchase and maintain, twin screw is better. Twin screw has a flexible screw design, self cleaning property and has a good mixing feature. It can also be used to process feed mix of higher fat content while single screw may not be able to process a material higher than 5% fat content. Extrusion cooking can be economical tool in production of pet foods because it can make use of animal byproducts that should have being discard into the environment hitherto leading to environmental pollution (Tran, 2008).

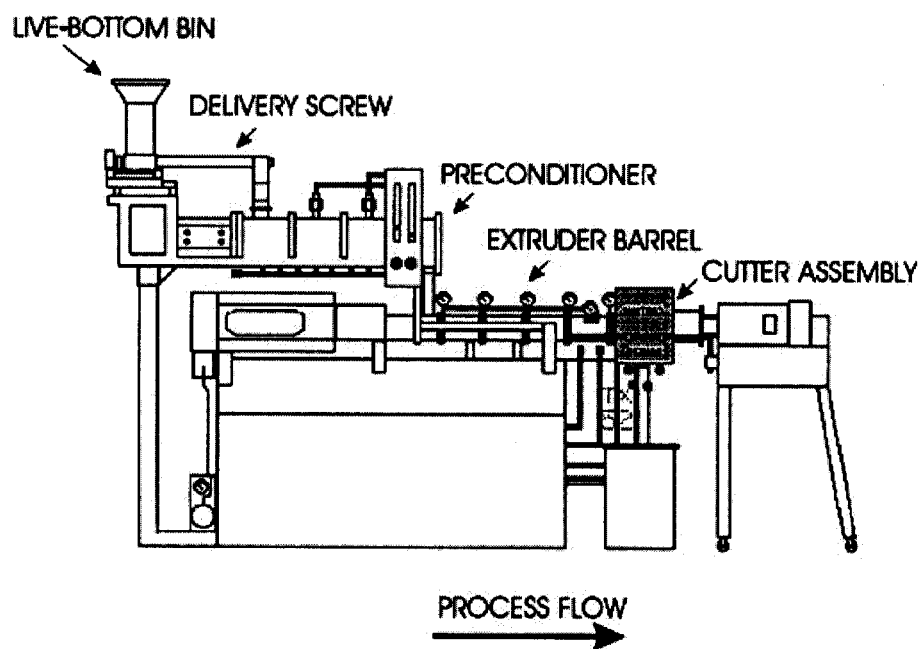

**Figure 5 An extruded processing line (Source from Sorensen, 2003)**

After particle size reduction and mixing and dosing, the materials to be extruded are moved into the feeder. These constantly supply the materials to be extruded into the processing line.

#### Pre process-conditioning

The mixes to be extruded are preconditioned. A precondition chamber may consist of two chambers and rotating shaft. The grain mixes with steam under controlled pressure as it turns for uniform addition of moisture and hot air comes in. This gives room for initial gelatinisation of the starch and the denaturation of the protein. It will also help the material to undergo easier friction processes. The precondition chamber allows the mash to reach a temperature of up to 90°C and moisture content of about 30%. The conditioner can also be

twin sided chamber as this will help in achieving a higher retention time and also achieve a higher gelatinised mash. The mashes are then moved into the extruder barrel.

### Extruder barrel

It is made up of screws element mounted round a shaft and a Sherlock which helps in proper mixing by reducing flow. The screws are configure in such a way to facilitate repeated mixing and conveying of mash and also generate pressure need to move them. The barrel consists of the feeding zone, the kneading zone and the final cooking zone. In the feeding zone, material is fed and preheated to melting temperature, while in the kneading zone the melting of the mash take place. Finally the pressure needed to push the material out is generated in the cooking zone. At the end of the barrel is the extruder die that prevents the outright flow of material which helps in pressure build-up and shear force that is needed for the mash to be plasticised. These are connected directly to a rotating knife that cuts extruded material to shape.

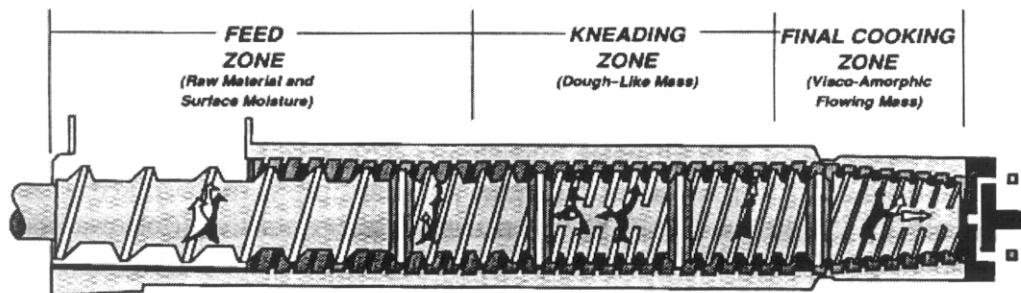

**Figure 6 Three principal different regions on the extruder screw.**

**(Source: Sorensen, 2003)**

When products to be extruded are introduced into the barrel after pre-conditioned, they undergo system of mixing contributed by the shear force from the surface of the barrel and rotating screw. With an increased moisture content which helps in softening the material, the temperature is dramatically increased to about 150°C. The temperature generated is generated through specific mechanical energy dissipation thus causing a high degree of gelatinization of starch and denaturing of protein. Though it may prevents cross linkage of bond in the amino acid due to high moisture content so destruction of essential amino acid is limited. The retention time is around 20 to 50 seconds. It should be noted that immediately after the

extruding the material, venting opening removes the steam thereby dropping the temperature within seconds to 35°C and also reduction of moisture content known as moisture flash off. The extruded material are then cut into shape as it is being moved out by rotating knives. These are moved into drier that reduce the moisture content to about 10% to prevent contamination by micro-organisms.

Vacuum coating of product of product is done after drying. This is the introduction of oil to increase the fat content to as high as 40% in fish feed. . It involves keeping the extruded pellet in a vacuum condition i.e. removing the air. After removing all the air, fats are introduced by spraying, the holes inside the pellet material are then filled with the fats as vacuum is equalised in the machine. It should be noted that extrusion with an increased temperature process requires more energy consumption and therefore it is much expensive, but the increase in temperature confer its own advantage. It will make the product to be pasteurized and thereby eliminating unwanted micro-organism. It will also contain are much higher fat content product thereby giving an increasing energy content to the animal (Sorensen, 2003)

#### Effects of extrusion process on nutritional quality

It is possible that protein digestibility may decrease with heat processing, even though extrusion process in a study carried out by (Sørensen, 2003, Lankhorst et al, 2007) showed that relatively at high temperatures have not affected protein digestibility significantly. Extrusion process may increase protein digestibility in plant protein sources due to the elimination of anti-nutrients factors such as protease inhibitors (Asp and Bjorck, 1989). Protease inhibitor causes reduced protein digestibility (Romarheim et al, 2005) and too much production of pancreatic enzymes leading to energy and protein loss and faeces excretion of proteases (Skrede and Krogdahl, 1985). Gelatinization of starch, increasing solubility of dietary fibre and reduction of oxidation in lipids can occur (Singh et al, 2007). It could be difficult monogastric such as dogs to digest un-gelatinized starch, extrusion cooking is unique because gelatinization occurs at much lower levels (12-22%) than is necessary (Camire, 2001) if enough moisture is present. The efficiency of inactivation of protease inhibitors during processing involving heat such as extrusion depends on other factors such as retention time in extruder, moisture, temperature, shear, presence of fats and oil (Asp & Bjorck, 1989; Lin et al, 1998). Maillard reaction between protein (free ε-amino group of lysine) and reducing sugars also occur leading to devalue of nutritional level of the protein; heat labile vitamins are also lost to a varying degree, (Singh et al, 2007; Hendriks et al, 1999) and also change in the

taurine status for cats (Hendriks et al, 1999). The proteins may undergo changes in structures forming a complex structure which cannot be utilized by the animal (digestive enzymes cannot split the complex) and also reduction in the availability of lysine (Williams et al, 2006; Opstvedt et al, 2003). Though variation of lysine reactivity and gelatinization of starch may occur during processing, these may be due to process variables and presence of different plant and animal source ingredients (Tran, et al. 2007). Extrusion also decreased digestibility of nitrogen, can increase ash absorption and may have no effect on dry matter and fat digestibility (Stroucken et al, 1996). In an experiment by Opstvedt et al, in 2003, they mention the impact of processing parameters such as temperature, shear, moisture and speed to have a great impact on protein quality. They also show significant reductions in protein digestibility, reactive lysine content. They confirm that the total process increased the content of D-aspartic acid and disulphide bonds. Extrusion significantly also lowered the apparent digestibility of nitrogen with faecal sample of extruded diet showing a lowered pH i.e. colonic fermentation in comparison with pelleted diet (Stroucken et al. 1996). Significant changes ( $P < 0.05$ ) in the true ileal digestibility of all amino acid nitrogen also occur with increasing heat treatment (Hendriks et al, 1999). However, Ljøkjel et al. (2004), concluded that extruded feed made at temperatures of 100°C, 125°C and 150°C could slightly reduce digestibility but the nutritional effect can depend on other processing variables such as duration of treatment (extrusion time), moisture, feeding rate and temperature of the extrusion

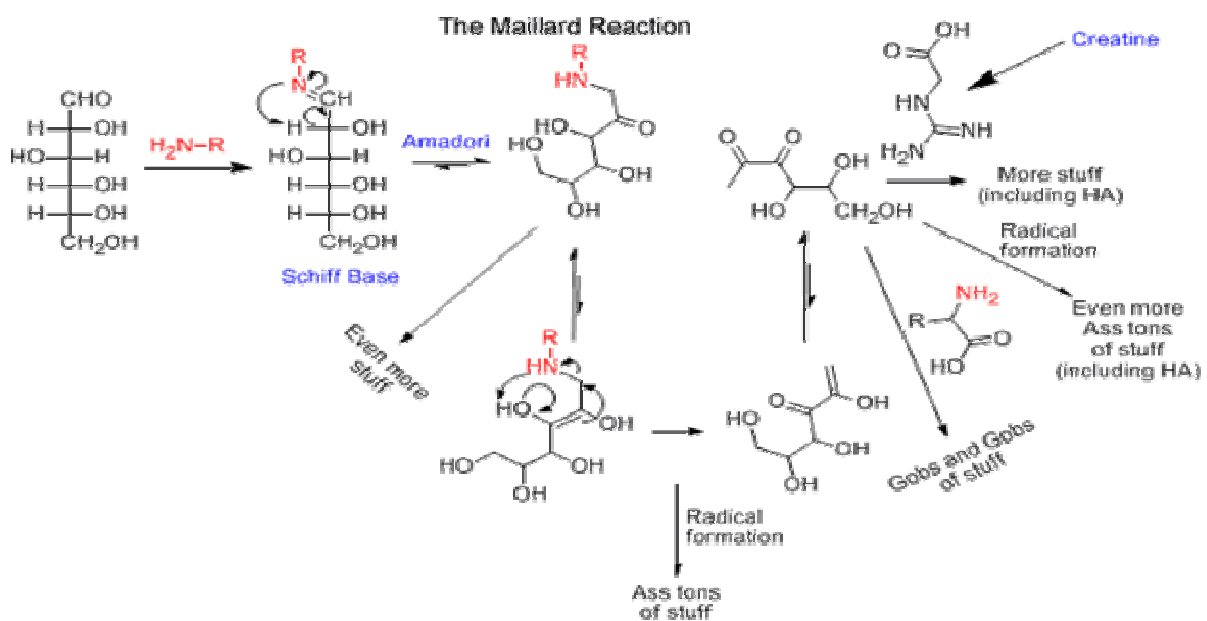

**Figure 7: Maillard reaction**

Source: <http://www.flavourgasmic.com/2009/06/the-why-of-brown/>

## Protein evaluation

Evaluation of protein quality is done analytically with several methods but with limitations. However feeding trial on a long term evaluation is better in getting the true quality of protein with well being of the pet in mind (Case et al, 2011). These analytical tests include:

(a) Chemical score: It compares amino acid composition of a given protein source with that of a reference protein of a high quality with a chemical score of 100 being given. During the test a deficit occur and the amino acid that shows the greatest value of deficit is known as the limiting amino acid. The chemical score shows in percentage, the amount of amino acid in the deficient protein in relation to the value in the reference protein. One limitation of using this method is that its value is based on the level of the most limiting amino acid in the protein without considering the proportions of all the remaining essential amino acids (Case et al, 2011).

(b) Essential amino acid index (EAAI): measures the geometric mean of the ratios of each of the essential amino acids in the test protein with values similar in the reference protein. It is then finally calculated as the proportion of the total nitrogen in a protein source contributed by essential amino acids (Case et al, 2011). Limitation of this method is similar value may be obtained on proteins of very different amino acid composition (McDonald, et al, 2011).

(c) Total essential amino acid content amount of the total nitrogen in a protein source that is contributed by essential amino acids (Case et al, 2011).

(d) Protein efficiency ratio: The process involves feeding test protein with a diet for several days to subject animal and changes in weight are calculated subsequently through weight gained by the subject and weight of feed consumed by the subject. The protein efficiency values shows the ability of a protein source can be convert to tissue deposit in growing animal. Limitation of this test may include inability to take into consideration other factors that may contribute to growth of the animal during test period may be overlook and this may influence the value (Case et al, 2011).

(e) Biological value is the percentage of absorbed protein that is retained by the body measured through an ability of the body to change absorbed amino acids into body tissue. One limitation of this measurement is that it fails to account for protein digestibility (Case et al, 2011).



(f) Net protein utilization is the product of biological value and digestibility of a protein. It takes into consideration the proportion of consumed protein retained by the body (Case et al, 2011).

### **Protein digestibility measurement in dogs**

Digestibility of nutrients is important as it gives the information about the amount of nutrient in the diet and used by the animal (Case et al, 2011). Since loss of indigestible matter as faecal material is a primary factor for variations in the nutritional value of feed ingredients (Bureau et al, 1999). Digestibility could also be used to measure the quality of the ingredients use in compounding the diet and also cost of production. It is also an indication to the quality of the ingredients use in the food. In manufacturing of pet food, different protein sources are use thus giving different amino acid composition and digestibility profile (Vhile et al. 2007). Because quality of a protein varies directly with the number and amount of essential amino acids it contains giving a state whereby digestibility is less for poor quality protein and poor quality diets (Lewis et al. 1990).

The use of true and apparent digestibility through controlled feeding trials can give digestibility coefficients that can be use for both economical and nutritional issue of production. Use of feeding trials tends to be accurate as it measures the absorption of nutrients as they go through the gastrointestinal tract and are absorbed into the body. Measured result provides digestibility coefficients for a food's dry matter (DM), crude protein (CP), crude fat (CF), and nitrogen free extract i.e. a measure of the carbohydrate fraction in the food (Case et al, 2011).

### **Measuring digestibility**

The small intestine is the actual location of digestion and absorption in monogastric mammals (McDonald et al. 2011), and it is imperative that bioavailability of nutrients occur during the digestion process. Bioavailability is the degree to which an ingested nutrient in a particular source is absorbed in a form that can be utilized in the animal metabolism (NRC, 2006).

Digestibility indicates the quality of the pet food, due to its ability to determine the proportion of nutrients in the food that are available for absorption into the body (Case et al, 2011).

Traditionally, in order to measure the protein digestibility in dog, we use total collection of faecal output correlating with the amount of feed consumed over specific period, or the use of

inert marker such as chromic oxide and yttrium oxide added at low concentrate as a marker (While 2007). These are analysed for nutrients, with the difference between these analysis assumed to be the digestibility value. The formula that is being use is:

$$\frac{(\text{Amount of nutrient in diet} - \text{Amount of nutrient in faeces})}{\text{Amount of nutrient in diet}} \times 100$$

(McDonald et al, 2011).

Measuring digestibility at the terminal region of the small intestine which is the main site for digestion and absorption is known as ileal digestibility. However, it is possible that some nutrients which fail to be absorbed in the small intestine are passed on to the large intestine (Meyer, et al. 1987). These are acted upon by the bacteria residing in the hind gut resulting in creation of several compounds nitrogen inclusive (Case et al, 2011). These with the microbial protein release by the hind gut microflora can alter the measuring parameters of the nutrients passing through the large intestine. Digestibility measurements that compare the amount of protein and amino acids left in the faeces related to the amount eaten are termed total tract digestibility (NRC, 2006).

However we have different ways of measuring faecal and diet digestibility in regards to how and where samples are taking which will be highlight below. In-vivo methodologies such as feeding trials are use by pet food industries (Case et al. 2011). Use of feeding trials tends to be accurate as it measures the absorption of nutrients as they go through the gastrointestinal tract and are absorbed into the body. These could be true and apparent digestibility.

#### Apparent digestibility in comparison with true digestibility

During the course of digestion, the organs involved in the process in the gut such as pancreas, gall bladder and the intestinal microbiota tends to secretes both enzymes and endogenous protein. These endogenous proteins will definitely interfere in the estimation of digestibility values of protein and amino acids in diet if not corrected. When endogenous protein is not taken into consideration in the calculation of digestibility value, then we refer to the value as apparent values (ileal or total). This is because the faecal or digesta samples contain metabolic waste products that originated from the animal and not from the food (Case et al, 2011).

Meyer et al, 1987 defines apparent digestibility of proteins as the net absorption of nitrogen containing substances, results from absorptive and secretory processes. Apparent digestibility can indicate the availability of energy and nutrients, thereby providing a rational basis upon which diets can be formulated to meet specific standards of available nutrients (Bureau, et al, 1999). To estimate the value of endogenous ileal amino acid and protein, methods that are used include among others: feeding protein free diets, diets containing synthetic amino acids, using labelled amino acids and proteins and the use of linear regression technique (Meyer et al, 1987). These methods depend on several other parameters to be included in the analysis.

Apparent digestibility gives an overall evaluation of nitrogen absorbed but not the measure of the quality or efficiency of utilization of nitrogen or of the individual essential amino acids (NRC, 2006).

True digestibility measurement of nutrients value takes into account the estimates of endogenous protein when digestibility measurements are being made. It is done by estimating the normal metabolic loss of the nutrient and deducting that value from the amount of the nutrient measured in the faecal matter (Case et al, 2011). The subject animals are given protein free diet on a short time and a baseline level of protein excretion is measured. The values established are used to account for the endogenous metabolic loss of protein in the faecal sample during subsequent digestibility trials (Case et al., 2011). Szymeczko & Skrede, 1990 also mentions that regression calculation can also be used to measure true digestibility.

True digestibility trials are most common. Hendriks & Sritharan in 2002, even mentioned in their paper that apparent faecal digestibility method is not an accurate method for the measurement of the absorption of crude protein and certain amino acids from canine diets even though their experiment was based on comparing protein digestibility value at the ileum with the total tract and they concluded that ileal digestibility was more accurate than total tract.

#### Total tract digestibility in comparison with ileal digestibility

Total digestive tract digestibility of protein in food is the percentage of ingested protein that is not excreted in the faeces as measured by input and output of nitrogen i.e. it compares the amount of protein and amino acids left in the faeces in relation to the amount eaten (NRC, 2006). It is based on difference between nutrients in feed and in faeces. A major challenge in

using total tract digestibility is the amount and the fates of nutrients that are escaping ileal absorption and undergoing changes with the aid of the microbiota in the hind gut are not known). Figure 8 illustrates which N-sources entering and leaving the large intestine and the possible degradation routes and the origin of N appearing in faeces. N-sources that are not coming from the feed and N-degradation processes will certainly affect the N-appearing in the faeces. The complexity of the metabolism taking place in the large intestine will therefore complicate the evaluation of the dietary protein source. Mink, which has limited microbial activity because of a small large intestine and rapid passage rate may therefore be an appropriate model animal to assess protein digestibility.

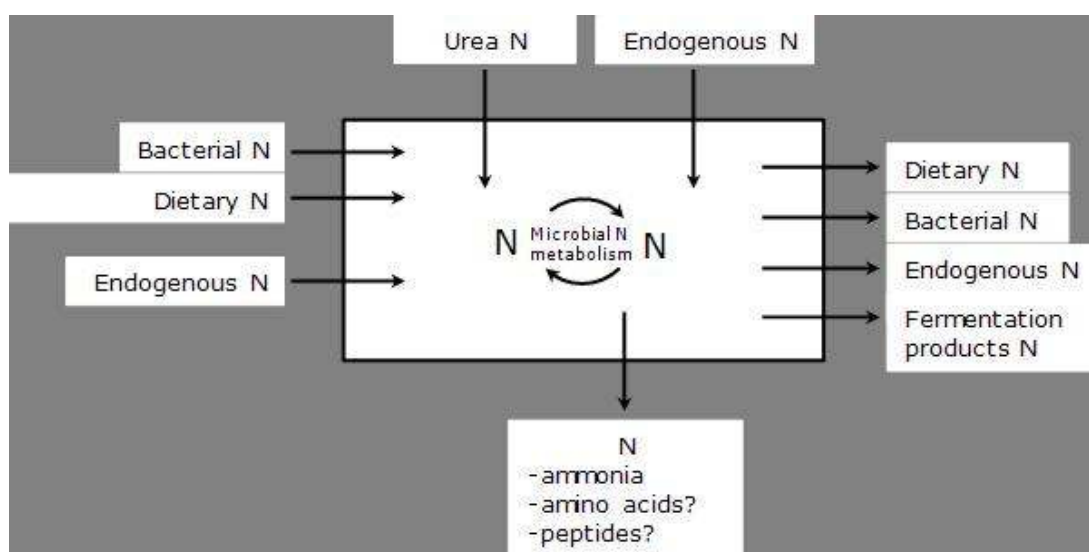

**Figure 8: N-sources entering and leaving the large intestine (Hendriks W. 2012, personal communication)**

Their (mink) digestive enzymes had little interference on fed diets with protein from different sources and a gradual lowering of the lysine, arginine and methionine were found in their digestive tracts. While the amounts of threonine, cystine and aspartic acid increased with increasing distance from the stomach. This indicates that the faecal digestibility method overestimates the amounts of absorbed amino acids as endogenous protein secretions may interfere with results.

Ileal digestibility is done when digesta samples are collected in the ileal end of the small intestine and the difference between the nutrients in feed intake and the digesta is correlated. This is done with affirmation that most of the absorption takes place in the small intestine. Exclusion of the effect of the microbial activity in the large intestine on the nutrients is the

aim of ileal digestibility measure. It could then be said that it gives exact information on digestibility as samples are taken before reaching the hind gut (Vhile, 2007).

Differences between ileal and total tract values were determined by Hendriks & Sritharan (2002) and they found differences in digestibility values between the two measured points. They concluded that ileal digestibility was more accurate than total tract but they wrote that obtaining a sample from the distal ileum could be challenging since ethical issues have to be considered as techniques involve intestinal dissection, ileal cannula and ileorectal anastomosis. But Hill et al, in 2001 published that total intestinal digestibility does not distinguish small intestinal digestion from colonic fermentation even though total intestinal apparent and true digestibility of soy protein seems to be similar or slightly less than that of other proteins fed to dogs.

## II. Experimental part

### Aim

The main objective of this study was to compare apparent total tract, colon and ileal digestibility of protein in dog with total tract digestibility in mink. Total tract digestibility in mink is a convenient and cheap method for protein digestibility assessment compared with studies in dogs. From earlier comparative studies with mink and dogs, it has been found that mink total tract protein digestibility values are lower than those in dogs (Ahlstrom & Skrede, 1998), suggesting that the values in mink may be close to ileal digestibility in dogs. If this holds true, it would be a great achievement in protein evaluation for dogs since ileal protein digestibility is the best measure for protein absorption and availability compared with total tract measurements. To obtain ileal digestibility values in dogs are complicated and the methods imply ethical considerations as ileal cannulated dogs are required. Mink digestibility experiments are invasive and can be carried out in a week's time.

### Mink as a model animal

The mink (*Neovison vison*) is in the same mammalian order Carnivora as the dog. It has a rapid rate of passage and very low microbial action/fermentation in the digestive tract; therefore the digestibility data obtained by the common faecal analysis method using mink will provide adequate information for many purposes (Szymeczko & Skrede, 1990), such as prediction of digestibility in other studies (Skrede, 1979; Skrede et al, 1980; While, et al, 2005a). The mink possess gastric stomach, short and uncomplicated intestine. Their low or non microbial action to food in the digestive tract may be due to the fact that they lack caecum and a short colon and summarily a short digestive tract designed for concentrated and highly digestible diets (Ahlstrom & Skrede, 1998). Digestibility studies with mink had shown promising results with regard to palatability and digestibility, though the digestibility value in comparing with the dog is lower but it is highly correlated (Ahlstrom & Skrede, 1998). This lower value of protein digestibility in mink may be due to the small influence of the microbial action in its digestive tract (Szymeczko & Skrede, 1990), which is much more pronounced in the dog (While et al, 2005b.) The advantage of using of mink as a model animal for protein digestibility studies for monogastrics and carnivores could also be due that the method is efficient and accurate and the mink produces small amount of faeces which can easily be collected (Ljøkjel, 2002). Its digestive system is also in comparison with that of fish

such as salmonids, where they show almost considerable similar results in digestibility value. However, the sensitive nature of their digestive system (mink and salmonids) makes them to give low digestibility value especially to protein source of low digestibility such as meat and bone meal (Skrede et al, 1980). This digestive system similarity may also be true with other monogastric species especially when measuring apparent amino acid digestibility and ileal digestibility (Skrede et al, 1998).

## Materials and methods

### Protein sources

Experimental diets were prepared with premix and in addition to the target protein source such as lambmeal, chickenmeal and fishmeal. They had already been evaluated in mink digestibility studies and showed protein digestibility values of lambmeal, 64.9 % (st. dev 1.2) (Norsk protein A/S, Hamar, Norway); poultry meal (low ash), 80.9 % (st.dev. 1.7) (Gepro, Depholz, Germany) and fish meal (Norse LT 94), 87.6% (st.dev 0.5), Norsildmel, Bergen, Norway.

**Table 5: Chemical composition of protein ingredients applied in the extruded dog food (g/kg)**

	<b>Lamb meal</b>	<b>Chicken meal</b>	<b>Fish meal LT 100</b>
<b>Dry Matter</b>	<b>947</b>	<b>944</b>	<b>928</b>
<b>Ash Content</b>	<b>175</b>	<b>119</b>	<b>130</b>
<b>Crude Protein</b>	<b>553</b>	<b>633</b>	<b>682</b>
<b>Crude Fat</b>	<b>119</b>	<b>133</b>	<b>92</b>
<b>Carbohydrate</b>	<b>100</b>	<b>59</b>	<b>24</b>

### Chemical analyses

Proximate analysis of protein ingredients used in the preparation of the diet were analysed (Table 5). The dry matter and the ash content were analysed by following procedure from the Association of official Analytical Chemists (AOAC) (1990). The Crude protein (Kjeldahl-N x 6.25) were also analysed also with procedure from AOAC (1990), however the crude fat percentage were determined by acid hydrolysis and petroleum ether extraction (98/64/EC). Procedure for the determination of the carbohydrate content was done by determining difference in the dry matter with the crude protein, crude fat and the ash content, i. e. Dry matter – (crude protein + crude fat + ash) (While et al, 2005b).

### Processing

The foods were produced at Center for feed manufacturing, fôrtek, UMB, Ås, Norway. Each diet were formulated and produced at 250 kg per batch. The protein and fat content in the

foods was planned to be at 25 and 20 %, respectively. The protein ingredients were mixed with a premix that contained (%); wheat meal, 64.3, corn meal, 18.4; rice meal, 5.5; beet pulp, 1.84; salmon oil, 2.80; limestone meal, 1.42; monocalcium phosphate, 1.90, sodiumchloride, 1.30; vitamin and mineral mixture, 2.52. The chemical content of the premix (%) was dry matter, 88.7; ash 0.7; protein, 12.1; fat, 5.0 and carbohydrates, 70.4. Before extrusion, all ingredients were ground in a hammermill (Model: E-22115 TF, Muench - Wuppertal, Germany driving by 18.5kW electric motor with speed of 3000 rpm) sieve size 1mm. The milled materials were transported into the mixing section by the aid of air suction fitted with the hammer mill by Jesma Co. (sprout Matador A/S, Esberg, Denmark) filled with a type DFC filter. Each diet was mixed using a Dinnissen (Pegasus Menger, 400 l, Sevenum, Holland) twin shaft high-speed mixer with a vitamin and mineral pre-mix and accurate weight of 0.1g yttrium oxide/kg was added manually in the paddle mixer to serve as a marker. Poultry fat was also added during mixing at the rate of 5 to 6% of the total batch weight. The food was conditioned in a Miltenz single shaft pre-conditioner (501S, Milliband Technology, Auckland, New Zealand), followed by extrusion in a twin screw extruder Bühler BCTB 62 extruder electric motor 45kW at 120C and an 8-mm die. The diets were dried to a moisture content 80g/kg using counter flow drier, Miltenz VC010 Gas. After drying an additional chicken fat was added at 20 % of diet weight using a vaccum coater Dinissen, 0.2 bar. The diets were then cooled (counter flow cooler, Munch-Edelstahl, Hilden, Germany) and stored for feeding trials.

**Table 6: Composition of experimental diets with different protein sources (%)**

	<b>Lamb Meal</b>	<b>Chicken Meal</b>	<b>Fish Meal</b>
<b>Premix*</b>	<b>48.96</b>	<b>54.38</b>	<b>55.25</b>
<b>Lamb Meal</b>	<b>34.49</b>	-	-
<b>Chicken Meal</b>	-	<b>29.11</b>	-
<b>Fishmeal</b>	-	-	<b>26.88</b>
<b>Yttrium</b>	<b>0.01</b>	<b>0.01</b>	<b>0.01</b>
<b>Total Raw Material</b>	<b>83.5</b>	<b>83.5</b>	<b>82.1</b>
<b>Total Chicken fat in feed</b>	<b>16.53</b>	<b>16.49</b>	<b>17.87</b>

\*See text above for composition



## Mink digestibility measurement

The mink digestibility study was carried out with four adult male mink that were fed each of the experimental diets. The experiment lasted for seven days, starting with a three days for adaptation followed by a four days period of quantitative collection of faeces. During the digestibility experiment the mink was kept individually in standard cages designed for quantitative collection of faeces and separation of urine. The animals were fed their respective feed rations once daily according to energy requirement, approximately 1.4 MJ metabolizable energy per day. The feed ration was a mix of 70 g feed and 140 g of water. Residual feed was collected daily to determine the actual feed intake, Faeces was collected once daily and kept frozen stored pending analysis.

## Dog digestibility measurement

### Apparent total tract:

The dog digestibility study was carried in adult in-mix breed dogs that were already decided to be put away by the owner. Four dogs were given each of the diets for ten days. On day seven samples of faeces was collected and frozen stored. The dogs were offered ration according to their proximate energy requirement (Table 7). During the experiment the dogs were confined in a 4 m leash attached to their individual outdoor house. The dogs were fed once daily and the feed was consumed rapidly. The dogs could not consume any other food during the experiment. On day ten the animals were put to sleep and the content of the colon and ileum were collected and immediately frozen in fluid nitrogen. All the dogs had been feed 2 hours and 11 hours before they were euthanized. The dogs were put to sleep by 1mg/kg BW Narcoxyl Vet and approximately 10 min after injected with 100mg/kg BW pentoparbital (Mebumal).

**Table 7: Characteristics of dog with feed and feeding requirement**

<b>Sex</b>	<b>Age (years)</b>	<b>BW before treatment (Kg)</b>	<b>BW after treatment (Kg)</b>	<b>Feeding per day (g)</b>
<b>Lambmeal</b>				
<b>Male</b>	<b>13</b>	<b>23.6</b>	<b>23.64</b>	<b>310</b>
<b>Female</b>	<b>3</b>	<b>18.2</b>	<b>19.14</b>	<b>270</b>
<b>Female</b>	<b>10</b>	<b>17.1</b>	<b>18.4</b>	<b>240</b>
<b>Male</b>	<b>7</b>	<b>26.8</b>	<b>26.34</b>	<b>350</b>
<b>Chickenmeal</b>				
<b>Male</b>	<b>13</b>	<b>24.3</b>	<b>26.12</b>	<b>300</b>
<b>Male</b>	<b>3</b>	<b>24.3</b>	<b>25.18</b>	<b>320</b>
<b>Female</b>	<b>8</b>	<b>24.3</b>	<b>25.34</b>	<b>280</b>
<b>Male</b>	<b>7</b>	<b>21.1</b>	<b>22.24</b>	<b>300</b>
<b>Fishmeal</b>				
<b>Female</b>	<b>10</b>	<b>22.6</b>	<b>22.44</b>	<b>300</b>
<b>Male</b>	<b>3</b>	<b>23.1</b>	<b>24.07</b>	<b>300</b>
<b>Female</b>	<b>1.5</b>	<b>19.4</b>	<b>20.37</b>	<b>240</b>
<b>Male</b>	<b>9</b>	<b>22.1</b>	<b>22.25</b>	<b>290</b>

## Statistics

The digestibility data were tested using analysis of variance by the GLM procedure of SAS (Statistical Analysis Systems Institute). Digestibility values for crude protein were tested in this model:  $Y_{ijk} = \mu + a_i + b_j + a_i b_j + e_{ijk}$ .

Where:

$\mu$  = general mean;

$a_i$  = fixed effect of method;

$b_j$  = fixed effect of protein source;

$a_i b_j$  = interactions between method and protein source

$e_{ijk}$  = random effect.

For every protein source, the effect of method on digestibility was tested by the GLM procedure. Differences between means were tested using the Students  $t$  Test (Least square means). A Pearson correlation coefficient ( $r$ ) was applied for covariance testing of method of digestibility measurement within each protein source.

## Result

### Food production

The production of the foods went well and the chemical contents of foods were close to planned concerning protein and fat which was the target for food similarity (Table 8). The higher ash content in the lamb meal compared with the poultry meal and the fish meal was reflected in the ash content of extruded food. Furthermore, since the inclusion level of lamb meal was highest, the room for the premix was reduced and the carbohydrate level became somewhat lower than for the other foods. The yttrium analyses confirmed that the marker had been homogeneously mixed into the foods. The expected content according to the molecular weight of  $YO_3$  was 100 mg/kg. By taking away the weight of oxygen the expected level was 0.78 mg/kg and the analyses values were only slightly below.

**Table 8: Proximate analysis of extruded dog food (%)**

	<b>Lamb meal</b>	<b>Chicken meal</b>	<b>Fish meal</b>
<b>Dry matter</b>	<b>93.7</b>	<b>91.9</b>	<b>91.6</b>
<b>Ash</b>	<b>12.5</b>	<b>6.8</b>	<b>7.5</b>
<b>Protein N*6.25</b>	<b>26.5</b>	<b>26.0</b>	<b>26.0</b>
<b>Fat</b>	<b>20.4</b>	<b>20.4</b>	<b>20.2</b>
<b>Carbohydrate</b>	<b>34.3</b>	<b>38.7</b>	<b>37.9</b>
<b>Yttrium</b>	<b>0.0077</b>	<b>0.0075</b>	<b>0.0074</b>

### Digestibility experiment

The experiment went well with subjects consuming diets appropriately and differences in feed left over were calculated appropriately to get the real value of feed consumed. The proximate analysis of both protein source use for diet and the extruded diet shows that a minor difference was confirmed (Table 5 and Table 9). With ash content of lamb meal source and diet containing lamb meal on the high side with values at 175g/kg and 12.5% respectively though its moisture content is lowest at 6.3% (Table 5). Even the crude protein content of the protein source is lowest for lamb meal at 553.31g/kg in comparing with others that have

higher crude protein content of 633.06g/kg and 681.63 g/kg for chicken and fish meal respectively (Table 5).

**Table 9: Digestibility values determined as apparent total tract in dogs compared with values obtained from digesta in colon, ileum in dogs and values from apparent total tract in mink**

	<b>Total tract, dog</b>	<b>Colon Dog</b>	<b>Ileal, Dog</b>	<b>Mink Total tract</b>	<b>SEM</b>	<b>P-value Method</b>	<b>P-value Protein source</b>
<b>All foods</b>	83.5a	78.5b	74.4c	77.8b	0.87	0.001	0.001
<b>Lamb meal</b>	77.7a	69.4b	66.3b	70.8b	1.99	0.01	
<b>Poultry Meal</b>	84.1a	79.8b	75.1c	77.3bc	1.21	0.001	
<b>Fish meal</b>	88.8a	86.6abc	81.9d	85.5c	0.82	0.006	

The results above (Table 9) represent the mean apparent total tract, colon ileal digestibility in dogs and also the mean total tract digestibility in mink. There was no significant interaction effect of method and protein source and the result was therefore not included in the table. The highest digestibility value of 88.8% was recorded with fish meal which was measured as the apparent total tract in dogs with ileal giving the lowest value of 81.9% and sampled measured at colon (86.6%) is closely related with that of mink total tract of 85.5% for the same protein source. The second protein source that recorded a higher value of mean digestibility is chicken meal. Its apparent total tract digestibility was 84.1% followed by colon digestibility with value 79.8% all measure in dogs. However the total tract digestibility value measured in mink is higher in comparison with ileal digestibility value of 77.3 and 75.1% respectively. The least recorded mean digestibility values in comparison with other protein source use in this experiment were in lamb meal. As mentioned earlier apparent total tract digestibility value in dogs recorded the highest with 77.1%, but surprisingly followed by the total tract digestibility value measured in mink followed up with 70.8%, followed closely with values from colon digestibility and ileal digestibility value both from dog with 69.4% and 63.3% respectively.

Statistically (Table 9 and 10), there is significant differences among digestibility values for all foods. However, mink total tract value and colon digestibility value in dog shows a significant correlated value; though very close but not the same digestible value. Apparent total tract value in dog is however far different in comparison with other food, followed by the poultry meal digestibility value. The same trend is observed in values for all protein sources however observation on fish meal where recorded where different values gives different significant correlation. The analysis of variance showed that both method and protein source had significant effect on the digestibility values (Table 9). Total tract digestibility values in dogs were higher than the other methods. Colon and mink digestibility values were significantly lower, but significantly higher than the ileal values. Regarding each of the protein sources there was a clear effect that with decreasing protein digestibility the difference between total tract values and the ileal value increased.

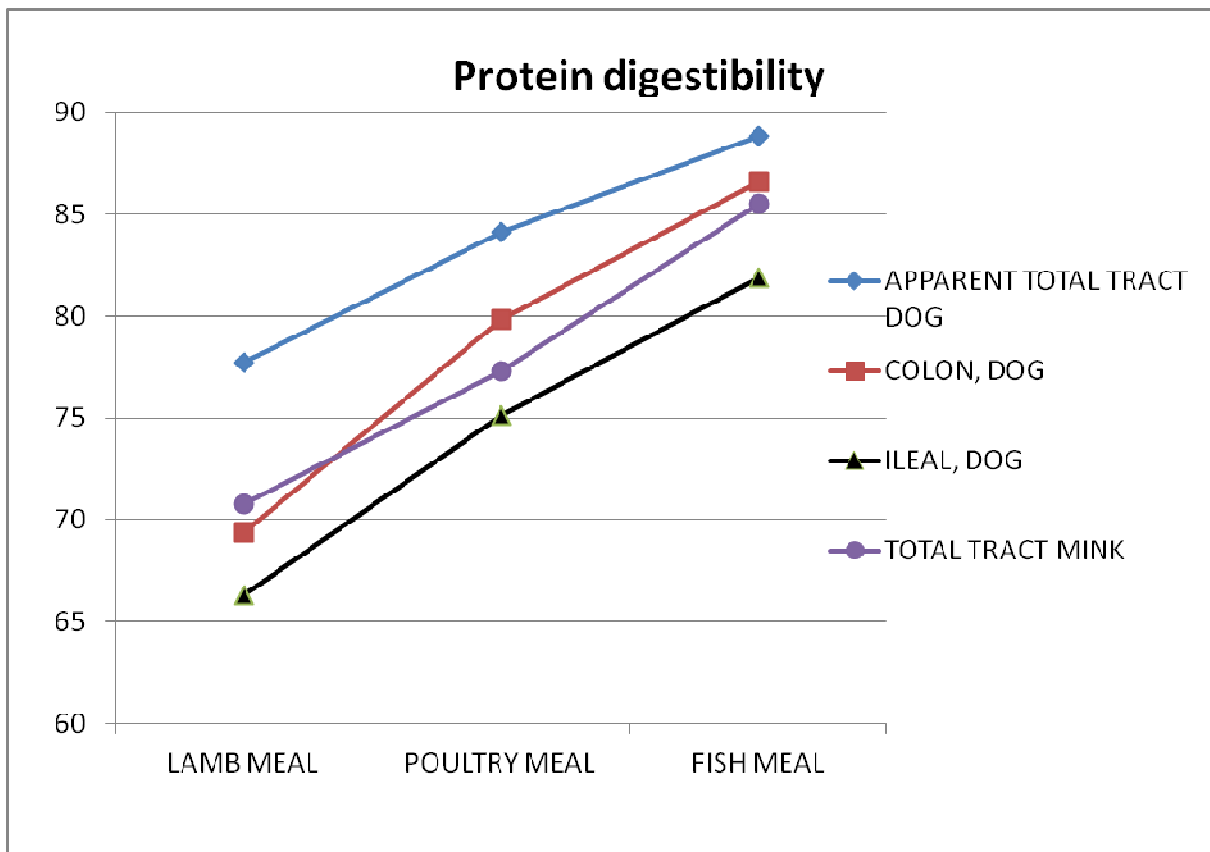

**Figure 8: Digestibility values determined as apparent total tract in dogs compared with values obtained from digesta from colon or ileum in dogs and values from apparent total tract in mink.**

## Correlations

Correlations between methods were high and highly significant. Digestibility values obtained from colon, ileum and mink total tract correlated positively with total tract values in dog at the approximately the same level. Digestibility in mink and ileum in dog, which was the main objective to validate in this study, correlated significantly.

**Table 10: Pearson correlation coefficients for digestibility determination**  
**P-values in parentheses**

	<b>Total tract, dog</b>	<b>Colon, dog</b>	<b>Ileal, dog</b>
<b>Colon, dog</b>	<b>0.882 (0.001)</b>		
<b>Ileal, dog</b>	<b>0.906 (0.001)</b>	<b>0.836 (0.007)</b>	
<b>Total tract, mink</b>	<b>0.894 (0.001)</b>	<b>0.959 (0.0001)</b>	<b>0.857 (0.001)</b>

## Discussion

Apparent total tract digestibility of protein in dog and mink

Considerable differences exist in mean digestibility result among the point of digestion as shown in the result for dogs. The highest digestibility is shown in apparent total tract, colon followed by ileal digestibility. The differences in protein digestibility values may be due to the fact that they are from different sources and also changes that occur during their passage through the hind gut. This is due to the extensive fermentation which occurs readily in dogs than in mink. This extensive fermentation is due to microbial activity in the colon and caecum in dogs which is absent in mink. This resulted in higher digestibility value in dogs compare to mink. It is possible that the protein produced in the hind gut may influence the value thereby contributing to increase in the apparent total tract digestibility. While, et al, 2005b, mentioned that the differences in protein and amino acid digestibility among species would depend on the specific amino studied, as well as on the properties of the protein source. Hendriks & Sritharan (2002) also confirmed that even though dogs have a short large intestine, but the microflora in the large intestines metabolises the endogenous nutrients entering it, thus causing an alteration on the digestible amino acid pattern. Ahlstrom & Skrede (1998), showed that mink have a lower total tract digestibility than apparent total tract in dogs and possible in

the colon digestibility as shown above for our result, which may be due to the more rapid passage of the digesta and very little post ileal fermentation and digesta in mink (Skrede, 1979).

Apparent total tract protein digestibility in dogs and mink were validated in two studies: (Ahlstrom & Skrede, 1998; While, et al, 2005a). These studies have shown that mink protein digestibility is lower than in dogs, but they are highly correlated. Our study confirmed this result concerning the lower digestive capacity in the mink compared with the dog and that correlations concerning digestibility was positively correlated. In the study by While et al. (2005a), the range in apparent protein digestibility among diets was from 84 to 89 % in dogs and from 78 to 86 % in mink. The range in the present study was wider, from 77.7 to 88.8 in dogs and from 70.8 to 85.5 in mink. The correlation coefficient between dog and mink digestibility was 0.739 in While et al. (2005), compared to 0.894 in our study. Ahlstrøm & Skrede (1998) determined an even higher correlation coefficient of 0.935, but the range in protein digestibility within species was not reported. The slight difference in the coefficients between the studies was most probably caused by variation in digestibility within the four animals comprising the experimental groups in the studies. Overall, the correlations are clearly pointing in the same direction in the three studies and our results confirm that apparent total tract digestibility in dogs can be predicted from those of mink.

Protein digestibility in dogs take mainly place in the small intestine by digestive enzymes and peptides and amino acids that the dog require will be absorbed in this part of the digestive tract. Applying ileal digestibility values will therefore be the most accurate method for evaluating a protein source. Studies have shown that total tract digestibility values are higher than ileal in dogs (Murray et al. 1998; Hendriks & Sritharan 2002) and in blue foxes (While et al. 2005a). Hendriks & Sritharan (2002) showed that total tract digestibility method resulted in higher apparent digestibility estimates compared to those of ileal digestibility method in dog. They concluded therefore that protein digestibility evaluation using total tract digestibility measurements was inaccurate since ileal digestibility values in general were lower and gave the true picture of protein and amino acids absorbed.

However, these results do not show similarity but they are comparable due to different protein sources and animal subject use for the experiment. The result confirms that highest digestibility value was pronounced in fish meal followed by chicken meal and lamb meal in dog and mink. This was confirmed by While, et al, (2005b) that ileal and total tract



digestibility of crude protein were significantly lower for diets containing meat meal compared with fish meal based diet, though their subject was fox and mink. Average apparent total tract digestibility was higher in dogs with 88.8% than total tract digestibility in mink with 85.5%. This result shows the same with both chicken meal and lamb meal, with differences as high as 6.8% for chicken meal and 6.9% for lamb meal. . The difference in the digestibility value of the protein source has to do with the raw material and processing conditions. The ash content is one indicator that is related to protein digestibility, high ash content indicates high levels of collagen which is less digestible than protein from muscle. The ash content in the lamb meal was 175g/kg in comparison with fish meal low temperature, 130g/kg (Table 5). The processing of the protein source can also affect the digestibility as lamb meal and chicken meal is processed at high temperature of over 133°C leading to formation of refolding of bonds of the protein. Therefore making it difficult for digestion enzymes to act on them in comparison with fish meal processed at low temperature to preserve its protein structure and value (Case et al, 2011).

#### Colon digestibility values

The nutrients absorbed in the colon are mainly sodium and water. Undigested material coming from the small intestine will not be absorbed but can be degraded by colonocytes present in the colon. In practice, ileal digestibility and total tract digestibility is applied protein evaluation and digestibility values obtained from colon is less in focused in experiments. Digestibility values measured with digesta from colon in the present experiment was carried out because we had the opportunity to do sampling at the same time as for sampling from ileum. The digestive process taking place in colon by microbial activity will make out the difference between ileal and total tract digestibility in the dog, and as shown in this study the difference depends on the protein source. The dogs were fed 11 h before sampling and it is there likely that the digesta from colon originated from that feeding. The difference in digestibility measured in colon and in faeces is due the further protein degradation and loss of N from volatile compounds such as ammonia. Our data fitted well into this by showing lower digestibility values in colon than for total tract, but higher than for ileum.

Data on protein colon digestibility measurements in dogs comparable to those in the present study has to my knowledge not been published earlier. Differences in protein digestibility

between ileum, colon and faeces in the present study were 74.4, 78.5 and 83.5 % , respectively (Table 9). Studies in weeks old piglets, which may have similar digestive capacity to an adult dog, have shown that apparent protein digestibility of digesta from ileum, distal colon and from rectum to be 61.9, 64.2 and 73.7 % , respectively (Asche et al. 1989). The piglet experiment applied a soymeal based feed with relatively low protein digestibility compared those of our study, but the relative difference between digestibility values of digesta from ileum, colon and faeces found in our study were similar to those reported in piglets.

The difference in total tract digestibility and colon digestibility was not similar for the three feeds. For the fish meal feed there was not a significant difference between the two digestibility values, but for the poultry meal feed and lamb meal feed with lower digestibility, the difference was significant. From this result one can conclude the lower the apparent total tract digestibility is, the lower the corresponding colon digestibility values will be. This relation is similar to what was observed when comparing ileal digestibility values and total tract values.

Even though in values, differences for colon digestibility in dog compare to total tract digestibility measurement in mink were observed but close similarities was recorded in the digestibility values for both i.e. correlations were observed in the values. The values for the colon digestibility in dogs in comparison to total tract digestibility in mink for the protein sources were very close with lamb meal recording 69.4% for the colon, and 70.8% for the total tract in mink, fish meal with shows 86.6% for the colon digestibility while 85.5% was recorded for the total tract digestibility for mink. However chicken meal pulled up surprise by its colon digestibility showing a higher value of 79.8% in comparison with total tract digestibility in mink with value of 77.3%. This study is probably the only study that confirms the relationship between the colon digestibility with ileal and total tract in dogs. These results show superiority of fish meal in terms of digestibility. This superiority of fish meal digestibility value is confirmed by Skrede in 1979 and also Szymeczko & Skrede in 1990. The same high digestibility value for fish meal was also confirmed by Vhile et al, in 2005a, with their result showing protein digestibility measured in the ileorectal anastomosis modified blue foxes (*Alopex lagopus*) from 81.0 to 86.4% and intact blue foxes from 82.5% to 86.4%. Even replacing diet containing fish meal with other protein sources such as meat meal and bacteria protein meal at 50% showed a lower ileal and total tract digestibility of crude protein.

## Ileal digestibility in dogs compared with apparent total tract digestibility in mink

The main aim of this study was to determine if mink total tract digestibility values were different from corresponding ileal digestibility values in dogs. The results showed higher total tract digestibility values found with mink for all the protein source i.e. 70.8% (lamb meal), 77.3% for (poultry meal) and 85.5% for fish meal in comparison with ileal digestibility value which shows values of value which shows values of 66.3%, 75.1% and 81.9% for lamb meal, poultrymeal and fish meal, respectively. Except for poultry meal feed, the differences was significant ( $P < 0.05$ ) and the digestibility values for mink were closer to colon values in the dog. Based on this result one can conclude that mink digestibility values for crude protein are in between total tract and ileal values in dogs, but generally closer to ileal values when protein digestibility is poor. This observation strongly indicates that mink digestibility is an appropriate model for ileal protein digestibility in the dog.

Since this study only included crude protein digestibility values one have to be aware of the fact that digestibility values for each amino acid could higher or lower than for crude protein as shown by Hendriks & Sritharan (2002) and While et al. (2005b). Therefore, to conclude more precise on the suitability of mink digestibility values as a model for protein ileal digestibility in the dog, information on amino acid digestibility are needed.

## References

- Ahlstrom O., Alden E., Borsting C. F., Dahlman T., Elnif J., Hansen N. E., Makela J., Polonen I. & Skrede A. (2004). Handbok for fôrmidler til pelsdyr, NJF-utredning/rapport nr. 502, Nordiske Jordbruks forskeres forening, subseksjon for pelsdyr, Ås.
- Ahlstrom O. & Skrede A. 1998. Comparative nutrient digestibility in dogs, blue foxes, mink and rats. *J. Nutr.* 128: 2676s-2677s.
- AOAC (Association of Official Analytical Chemists International). 1990. Official methods of analysis, 15<sup>th</sup> edition. Association of Official Analytical Chemists, Washington, DC.
- Asche, G.L., Austin, J.L. & Peo, R.P. Jr. 1989. Protein digestion in weanling pigs: Effect of feeding regime and endogenous protein secretion. *J. Nut.* 119: 1083-1092.
- Asp N.-G. & Bjorck I. 1998. Nutritional properties of extruded foods. In: Mercier C., Linko P., Harper J. M. (Eds.), *Extrusion cooking*. AACC, St. Paul. Minnesota, USA, pp. 399-434.
- Baskot S. 2004. Msc thesis; Production of pet food- Inclusion of palatability enhancers in dry extruded dog food. Norwegian University of Life Sciences, Ås, Norway.
- Bradshaw J. W. S. 2006. The evolutionary basis for the feeding behaviour of domestic dogs (*Canis familiaris*) and cats (*Felis catus*). *J. Nutr.* 136: 1927s-1931s.
- Bureau D. P., Harris A. M. & Cho C. Y. 1999. Apparent digestibility of rendered animal protein ingredients for rainbow trout (*Oncorhynchus mykiss*). *Aquaculture* 180: 345-358.
- Camire M. E., 2001. Extrusion and nutritional quality In: Guy R. (Ed.), *Extrusion cooking, technologies and applications*. Woodhead publishing Ltd. Cambridge, pp. 108-129.
- Case L. P., Daristotle L., Hayek M. G. & Raasch M. F. 2011. *Canine and Feline Nutrition; A resource for companion animal professionals*. (3<sup>rd</sup> Ed.). Mosby Elsevier, Missouri, USA. pp.1-185. ISBN: 978-0-323-06619-8.
- Cramer K. R., Greenwood M. W., Moritz J. S., Beyer R. S. & Parsons C. M. 2007. Protein quality of various raw and rendered by-product meals commonly incorporated into companion animal diets. *J. Anim. Sci.* 85: 3285-3293.

Dust J. M., Grieshop C. M. Parsons C. M., Karr-lilienthal L. K., Schasteen C. S., Quigley J. D., Merchen 111 N. R. & Fahey Jr. G. C. 2005. Chemical composition, protein quality, palatability, and digestibility of alternative protein sources in dogs. *J. Anim. Sci.* 83: 2414-2422.

Edison Serrano, 2011. Phd thesis. Biological responses in rainbow trout (*Oncorhynchus mykiss*) after dietary intake of lupine seeds and quinolizidine alkaloids. Norwegian University of Life Sciences, As, Norway. ISBN 978-82-575-0982-8.

European Community Directive, 1998. EC, Commission Directive 98/64/EC. European Commission. Brussels.

Folador J. F., Karr-lilienthal L. K., Parsons C. M., Bauer L. L., Utterback P. L., Schasteen C. S., Bechtel P. J. & Fahey Jr. G. C. 2006. Fish meals, fish components, and fish protein hydrolysates as potential ingredients in pet foods. *J. Anim. Sci.* 84: 2752-2765.

Halpin K., 2001. Investigating the use of specialty ingredients in pet food products; In Novel applications in pet food industry; A watt publication, May 2001 Ed. USA. [www. Petfoodindustry.com](http://www.petfoodindustry.com).

Hansen J. O., Penn M., Overland M., Shearer K. D., Krogdahl A., Mydland L. T. & Storebakken T. 2010. High inclusion of partially deshelled and whole krill meals in diets for atlantic salmon (*Salmon salar*). *Aquaculture* 310: 164-172.

Hendriks W. H., Emmens, M. M. A. Trass B. Pluske J. R. 1999. Heat processing changes the protein quality of canned cat food as measured with a rat bio-assay. *J. Anim. Sci.* 77: 669-676.

Hendriks W. H. & Sritharan K. 2002. Apparent ileal and fecal digestibility of dietary protein is different in dogs. *J. Nutr.* 132: 1692S-1694S.

Hill R. C., Burrows C. F., Ellison G. W. & Bauer J. E. 2001. The effect of texturized vegetable protein from soy on nutrient digestibility compared to beef in cannulated dogs. *J. Anim. Sci.* 79: 2162-2171.

Johnson M. L., Parsons C. M. Fahey Jr., Merchen N. R. & Aldrich C. G. 1997. Effects of species raw material source, ash content, and processing temperature on amino acid

digestibility of animal by-product meals by cecectomized roosters and illegally cannulated dogs. *J. Anim. Sci.*76: 1112-1122.

Lankhorst C. Tran Q. D., Havenaar R., Hendriks W. H. & van der Poel A. F. B. 2007. Effects of extrusion on the nutritional value of canine diets as assessed by in-vitro indicators. *Anim. Feed Sci. Technol.* 138: 285-297.

Lewis D. L. Morris M. L. & Hand M. S. 1990. *Small Animal Clinical Nutrition* (3<sup>rd</sup> ed.). Mark Morris associates, Topeka, Kansas. Pp. 12-17.

Lin S., Hsieh F. & Huff H. E. 1998. Effects of lipids and processing conditions on lipid oxidation of extruded dry pet food during storage. *Anim. Feed Sci. Technol.* 71: 283-294.

Ljokjel K. 2002. Phd thesis. Nutritional effects of heat treatment of feeds; effects on digestion of protein, amino acids and starch in mink, rainbow trout and dairy cows. Norwegian University of Life Sciences, As, Norway.

Ljokjel K., Sorensen M., Storebakken T. & Skrede A. 2004. Digestibility of protein, amino acids and starch in mink (*Mustela vison*), fed diets processed by different extrusion conditions. *C. J. Anim. Sci.*84: 673-680.

McDonald P., Edwards R. A., Greenhalgh J. F. D., Morgan C. A., Sinclair L. A. & Wilkinson R. G. 2011. *Animal nutrition* (7<sup>th</sup> Ed.). Prentice Hall, Harlow, England. pp.692. ISBN 978-1-4082-0423-8 (pbk).

Meyer H., Schunemann C., Elbers H. & Junker S. 1987. Precaecal and post ileal protein digestion and intestinal urea conversion in dogs. In; *Nutrition, malnutrition and dietetics in the dog and cat. Proceedings of an international symposium, Hannover, Germany* (Edney, A. T. B. ed.), pp.27-30. British Veterinary Association. London, UK.

Murray S. M., Patil A. R., Fahey Jr. G. C., Merchen N. R. & Hughes D. M. 1997. Raw and rendered animal by-products as ingredients in dog diets. *J. Anim. Sci.*75: 2497-2505.

National research council, 2006. *Nutrient requirements of dogs and cats.* National research council, National academies press, Washington D. C. ISBN 0-309-08628-0 (Hardcover).

- Opstvedt J., Nygard E., Samuelsen T. A., Venturini, G., Luzzuna U. & Mundheim H. 2003. Effect on protein digestibility of different processing conditions in the production of fish meal and fish feed. *J. Sci. Food Agric.* 83: 775-782.
- Overland M., Kjos N. P. & Skrede A. 2004. Effect of bacteria protein meal grown on natural gas on growth performance and carcass traits of pigs. *It. J. Anim. Sci.* 3: 323-336.
- Overland M., Romarheim O. H., Ahlstrom O., Storebakken T. & Skrede A. 2007. Technical quality of dog food and salmon feed containing different bacteria protein sources and processed by different extrusion conditions. *Anim. Feed Sci. Technol.* 134: 124-139.
- Overland M. Sorensen M., Storebakken T., Penn M., Krogdahl A. & Skrede A. 2009. Pea protein concentrate substituting fish meal or soybean meal in diets for atlantic salmon (*Salmo salar*)- effect on growth performance, nutrient digestibility, carcass composition, gut health and physical feed quality. *Aquaculture* 288: 305-311.
- Romarheim O. H., Aslaksen M. A., Storebakken T., Krogdahl A. & Skrede A. 2005. Effect of extrusion on trypsin inhibitor activity and nutrient digestibility of diets based on fish meal, soybean meal and white flakes. *Arch. Anim. Nutr.* 59: 365-375.
- Singh S., Gamlath S. & Wakeling L. 2009. Nutritional aspects of food extrusion; a review. *Int. J. Food Sci. and technology* 42: 916-929.
- Skrede A. 1979. Utilization of fish and animal by-products in mink nutrition IV. Fecal excretion and digestibility of nitrogen and amino acids by mink fed cod (*Gadus morhua*) fillet or meat-and-bone meal. *Acta Agric. Scand.* 29: 241-257.
- Skrede A. & Ahlstrom O. 2002. Bacterial protein produced on natural gas; A new potential feed ingredients for dogs evaluated using blue fox as a model. *J. Nutr.* 132: 1668S-1669S.
- Skrede A., Berge G. M., Storebakken T., Herstad O., Aarstad K.G. & Sundstol F. 1998. Digestibility of bacteria protein grown on natural gas in mink, pigs, chicken and atlantic salmon. *Anim. Feed Sci. Technol.* 76: 103-116.
- Skrede A., Krogdahl A. & Austreng E. 1980. Digestibility of amino acids in raw fish flesh and meat-and-bone meal for the chicken, fox, mink and rainbow trout. *Zeitschrift fur Tierphysiologie, Tierernahrung und Futtermittelkunde.* 43: 92-101.

Skrede A. & Krogdahl A. 1985. Heat affects nutritional characteristics of soybean meal and excretion of proteinases in mink and chicks. *Nutr. Rep. Int.* 32: 479-489.

Smeets-peeters M., Watson T., Minekus M. & Havenaar R. 1998. A review of the physiology of the canine digestive tract related to the development of in-vitro systems. *Nutr. Res. Rev.* 11: 45-69.

Sorensen M. 2003. Phd thesis. Nutritional and physical quality of fish feeds extruded at various temperatures. Norwegian University of Life Sciences, As, Norway. ISBN 82-575-0540-4.

Suontama J., Kiessling A., Melle W., Waagbo R. & Olsen R. E. 2007. Protein from northern krill (*Thysanoessa inermis*), antarctic krill (*Euphausia superba*) and the arctic amphipod (*Themisto libellula*) can partially replace fish meal in diets to atlantic salmon (*Salmo salar*) without affecting product quality. *Aquac. Nutr.* 13: 50-58.

Stroucken W. P. J. van der Poel A. F. B. Kappert H. J. & Beynen A. C. 1996. Extruding vs Pelleting of a feed mixture lowers apparent nitrogen digestibility in dogs. *J. Sci. Food Agric.*: 520-522.

Szymeczko R. & Skrede A. 1990. protein digestion in mink. *Acta Agric. Scand.* 40: 189-200.

Tran Q. D. 2008. Phd thesis. Extrusion processing; effects on dry canine diets. Wageningen University and Research Centre, Wageningen, The Netherlands. ISBN 978-90-8504-903-6.

Tran Q. D. van Lin C. G. J. M., Hendriks W. H. & van der Poel A. F. B. 2007. Lysine reactivity and starch gelatinization in extruded and pelleted canine diets. *Anim. Feed Sci. Technol.* 138: 162-168.

Vhile S. G. 2007. Phd thesis. Nutrient digestibility in dogs (*Canis familiaris*) and model carnivore species. Comparative studies on protein and amino acid digestibility in dogs, blue foxes (*Alopex lagopus*) and mink (*Mustela vison*) fed various protein sources using different determination methods. Norwegian University of Life sciences As, Norway. ISBN 978-82-575-0768-8.



Vhile S. G., Skrede A., Ahlstrom O. & Hove K., 2005a. Comparative apparent total tract digestibility of major nutrients and amino acids in dogs (*Canis familiaris*), blue foxes (*Alopex lagopus*) and mink (*Mustela vison*). Anim. Sci. 81: 141-148.

Vhile S. G., Skrede A., Ahlstrom O. Szymeczko R. & Hove K., 2005b. Ileal and total tract nutrient digestibility in blue foxes (*Alopex lagopus*) fed extruded diets containing different protein sources. Arch. Anim. Nutr. 59: 61-72.

Williams P. A., Hodgkinson S. M. Rutherford S. M. & Hendriks W. H. 2006. Lysine content in canine diets can be severely heat damaged. J. Nutr. 136: 1998S-2000S.

[www.ats.agr.gc.ca/inter/5504-eng.htm](http://www.ats.agr.gc.ca/inter/5504-eng.htm). Downloaded on 04.04.2011.

[www.britannica.com/EBchecked/topic/199193/extruder](http://www.britannica.com/EBchecked/topic/199193/extruder). Downloaded on 10.1.2012.

[www.flavourgasmic.com/2009/06/the-why-of-brown/](http://www.flavourgasmic.com/2009/06/the-why-of-brown/) Downloaded on 21.1.2012

[www.meriden.com.cn/Simplified/NewsView.asp?ID=692&SortID=25](http://www.meriden.com.cn/Simplified/NewsView.asp?ID=692&SortID=25). Downloaded on 04.04.2011.

[www.ucd.ie/vetanat/images/43.gif](http://www.ucd.ie/vetanat/images/43.gif) downloaded on 10.1.2012.