

FORMAL HOUSING CONCEPTS FOR INFORMAL SETTLEMENTS.
FOR IN PARTICULAR; KHAYELITSHA

ANDREW BLAIR

NORWEGIAN UNIVERSITY OF LIFE SCIENCES
DEPARTMENT OF LANDSCAPE ARCHITECTURE AND SPATIAL PLANNING
MASTER THESIS 30 CREDITS 2012



Formal housing concepts for informal settlements;
for in particular, **Khayelitsha**

“recognise informality as a process that can positively shape urban space”
(Huchzermeyer, M 2009)



IMAGE (WWW.MAPS.AFRIGIS.CO.ZA)



South Africa

Khayelitsha, Cape Town

Project description:

The project looks at the current housing situation in South Africa. It brings to point possible alternatives and methods that could in the end help public and private agencies provide a better standard of living to those living in poverty areas. In particular for those living in Khayelitsha.

Table of Contents:

Overview - 4

The positives; RDP housing program	-	7
The negatives; RDP housing program	-	8
The positives; slum living conditions	-	9
The negatives; slum living conditions	-	10

Khayelitsha - 11

Characteristics; Khayelitsha (the new home)	-	14
Density, Units per area	-	15
Density, Persons per area	-	16
Comparing structures;	-	17
Analysis, Khayelitsha informal settlement	-	18
Density, Khayelitsha informal settlement	-	19
Population numbers, comparisons	-	20

In-situ upgrade - 21

Question; what should be done with Khayelitsha's informal settlement?	-	22
Concept; providing it part build	-	24
Structure; without homes	-	28
Structure; with homes	-	29

Expanding - 32

Basis; new settlements	-	33
Unique spaces; various clusters	-	34
The hut; cluster 5	-	35
Concluding thoughts . . .	-	40
References	-	41



Overview



APARTHEID ERA SOUTH AFRICA INVOLVED THE SEPARATION OF COLOURS AND THE ESTABLISHMENT OF INFORMAL SETTLEMENTS. IMAGE(WWW.PMBHISTORY.CO.ZA)

How it began:

The end of Apartheid began with the release of Nelson Mandela from Prison in February 1990. In 1994 he became president of South Africa, now having to deal with all the problems Apartheid left behind. As part of addressing huge poverty, the ANC introduced the Reconstruction and Development Programme (known in short as RDP) which among other things provides sufficient housing to those living in poor conditions. During a six year period between 1994 and June 2010, the government built over 2,7 million homes for South Africans, giving shelter to more than 13 million people (South African Government Information, 2011).

The RD Program has in many areas addressed certain

issues and been successful. However concerning the housing program there have been some down falls, although nothing unusual for a developing country dealing with a large growing population. One of the key problems is simply trying to meet the growing demand for homes. The task becomes even harder when such a large part of the population are living in informal settlements ([slums](#)) and are constantly increasing.

The RDP promised initially 300 000 built homes per year. The fiscal budget for 2010/2011 allocated 12,4 billion (South Africa Rand) translating to 226 000 newly built homes. **This is 74 000 homes short** of the RDP promise. The deficit in homes could partly be due to what Mthembu-Mahanyele stated in 2001, "we will be slowing down further - we have to look at the quality issue and at tenure alternatives" (Richard Knight, 2001). However the problem does not solely lie with meeting 300 000 units per year, there is a problem with where these homes are being placed and how they are built. 10 years after the introduction of the program politicians have met much criticism for the de-fragmented communities, poor location and infrastructure, and poor quality homes being delivered. In conclusion a comprehensive review was undertaken.

The objective of the reviews were to assess the outcomes of the program as well as determining the current socioeconomic situation in the country (DoHS, 2009). The review lead to the creation of the Comprehensive Plan for Sustainable Human Settlement. According to the National Housing Code document, the primary aims of the Comprehensive Plan are now focused upon "improving the quality of housing and housing environments by integrating communities and settlements" (DoHS, 2009b). It also sets out to promote housing quality and improve sustainability through social and economic facilities. **It became clear that simply building 4 walls and roof was not going to solve the housing problem.** The inhabitants want a home, which consists of more than the just 4 walls and roof.

Not over yet:

The Comprehensive Plan hasn't solved everything yet. It appears that implementation has become another obstacle.

Associate Professor, Marie Huchzermeyer, at School of Architecture and Planning, University of the Witwaterstrand in South Africa, wrote a paper titled "The struggle for in situ upgrading of informal settlements: a reflection on cases in Gauteng" where she states how local authorities have failed to recognize several informal settlements as part of the Informal Settlements Upgrading Programme. She goes on to further state that 'their requests were met with great reluctance by local government'. Here we can see that even though there are the tools to address the problem, they are not being used. It becomes clear here that the problem now lies internally within the government. It could be that the authorities simply do not have the resources to address the issue or that they do want to use their resources on this problem.

Handling Methods:

It is presumed that majority of the public housing projects in South Africa are government handled since that constitution states its governments responsibility to provide the poor housing. This in simple terms is a top down method; the decisions and funding come from the top, by public authority figures. This is in contrast to community established or rather a 'self help' initiatives which are born from the from bottom up. The two methods are both structured differently and both will yield different results. A project started from a grass roots level is a collective effort. Its a community initiative that is often seen as more dynamic, more flexible, accommodating and more sensitive to local needs but however may seem to lack farsighted strategic goals.

A successful example of a bottom up method is the Orangi Pilot Project that took place in Karachi Pakistan. It was a collaboration between a local Pakistan charity and renowned social scientist Dr. Akhtar Hammed Khan. The projects objectives were to provide technical support for the provisions of physical and social infrastructures (low cost sanitation, housing, basic health and educational services) to an informal settlement area in Orangi (Sun Academia, 2010). Some of the major problems the project encountered were the availability of funds and the lack of community participation and ownership. These two major problems are similar to the problems the authorities in South Africa are facing; funds for housing are lowering while community cohesiveness and involvement even less.

The Orangi Pilot Project; through using local labour and resources the project provided improved sanitation and helped establish a better community structure, helping unit the new immigrants to the area. The community based initiative proved to be a far more efficient and cheaper method when compared to the government run project on the other side of the township. The government run initiative supplied sanitation to roughly 36 housing lanes over a six year period. Meanwhile the open ended community based

initiative supplied 4000 lanes at one third the price (Sun Academia, 2010).

Through this community project, people gained a sense of belonging and became socially integrated. To the authoritative figures the project lacked goal orientated strategies that are typical of governmental projects (Sun Academia, 2010). Whats even more interesting here is that it was a success even though it was a community based approach (bottom up method) and not government led.

Its no secret that goal orientated strategies work seamlessly in first world country where political structures are more cohesive and open, however in third world countries, the co-ordination of the work becomes much more complex and management of funds are less visible. I think its important to consider the results a community based initiative can yield. As in the end it could provide the poor more homes to the poor and lessen the stress upon local authorities and governments

Main aim:

The project will not go further into the best handling methods for implementing housing but rather offer other qualities that would help solve the housing problem in South Africa. They will be achieved through;

- 1) raising awareness and understanding of those living in informal settlements,
- 2) offer an alternative to the current type of home being built with the aim of eliminating the backlog of homes
- 3) provide alternative methods that improve the quality of life of those living in informal settlement areas.

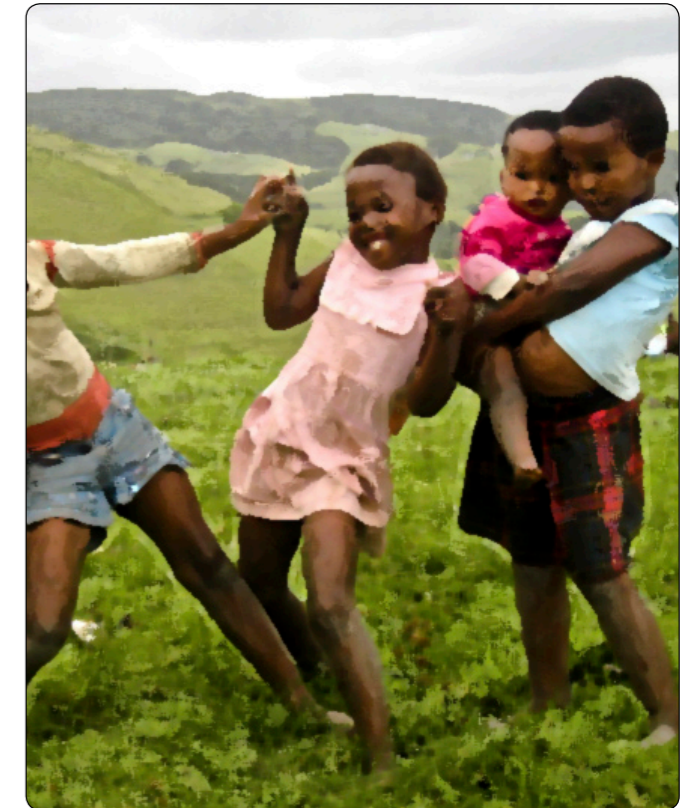

Section 26 of the Constitution of the Republic of South Africa, 1996, states that everyone has the right to “[access to adequate housing](#)” (Richard Knight, 2001)

The positives; RDP housing program

There is no doubt the improvements the RDP has made for underprivileged South Africans. The program has dealt and solved many issues created by Apartheid. Below are a few concerning the housing program.

Improved housing 2,7 million new homes Electricity/water Lower Co² Affordable Income Better security Protection from elements personal asset

Improved Housing : The housing program has offered improved housing to those forced to live in below standard living conditions under the Apartheid regime.

2,7 Million new homes : Under the current RDP program, between 1994 and June 2010, the government built over 2,7 million homes for South Africans, giving shelter to more than 13 million people (SAGI, 2011)

Electricity/Water : Many now have access to electricity and water. Electricity has in many cases replaced the use of coal/fire as a cooking medium, creating a safer environment.

Lower Co² : Electricity can also substitute the use of coal for heating and in return, lower Co² emission and increased habitants health.

Affordable : RDP houses are considered cheap to build, costing roughly R53,000 (\$7200) per unit.

Income : Now in possession of a home, the citizen owns a valuable asset, with the option to generate income through renting.

The negatives; RDP housing program

Although the program has achieved many great things, it lacks many basic elements key to a better standard of living and healthier society.

Low Quality
Wrong motivation
Cheap Sold/
abandoned
Fear moving
Lacking Design
Obscured freedom



NEW RDP HOUSES CAPE TOWN. IMAGE (WWW.CMA.ORG.ZA)

Low Quality : Many RDP houses are poor in quality and lack infrastructure. Authorities are having to repair the newly built homes and in certain cases must completely rebuild the home.

Cheap : Cheap to build but poorly insulated. The costs of keeping these houses heated come out of the earnings of the people who can least afford to pay them. Heating can cost poor people up to 66% of their income (Helene Le Roux, 2003)

Wrong motivation: The motivation behind replacing shacks is to provide a better living condition for its people. Certain projects were prioritized due to their location and to clean up the area so as to avoid tourist seeing them. Housing backlog alone for the city of Cape Town is 245 000 homes.

Sold/Abandoned : Many houses are sold or abandoned with tenants moving back to the slums. Possible reasons

- 1 - Lesser value is placed on the houses when they are given free. Little attachment to the property.
- 2 - Houses are sold/rented to earn money, meaning they would be happier somewhere else
- 3 - Poor quality, lack of community

Fear of moving: Many of the inhabitants in slums fear being relocated, due to harsh way evictions and relocations are carried out (Marie Huchzermeyer, 2009).

Lacking in design: The layout of the new housing communities often lacks design and are poorly situated. It does not seem to take into account the occupants former lifestyle patterns.

Obscured Freedom: The free feeling (organic structure) of the slum is replaced by a highly ordered design.

The positives; **slum** living conditions

The following quote was taken from a European student whom visited a home situated in a informal settlement. *“The room had old sofa and chairs, a table, a worn carpet on the floor, curtains at the window and a big stereo sound system. It was brightly painted and made as comfortable as possible”*

Intimate Expressive
Colourful **Low consum-**
ing Intricate Network
Mixed Use **Inherit freedom**



INFORMAL SETTLEMENT CAPE FLATS, CAPE TOWN. IMAGE (HTTP://CPTADVENTURES2010.BLOGSPOT.COM)



BED & BREAKFAST: SOME HOMES DOUBLE AS A BUSINESS ATTRACTING TOURIST AND VISITORS. IMAGE (WWW.FLICKR.COM)

Intimate : Where space is preciously used, the homes and the surroundings are often intimate and of a personable scale

Expressive: With many of the home self built, the homes are often personalized, each quite unique, displaying various colours, textures and irregular shapes personally chosen

Colourful: What’s interesting about the townships in South Africa is that they are extremely colourful. Like the various colours used within each tribal tradition, these colours are prevelant even with in the informal settlements

Low consuming: There are few formalized areas that can reach such a high density as within a slum. And despite even this, infomalized areas occupy less land per inhabitant and consume less resources.

Intricate Network: Many of these informal settlements have been around since the beginning of Apartheid and since then, many closely knitted communities have evolved

Mixed Use: Shops and services are often set up individually and often in their own homes. Overheads are presumed low since all is being operated from within their home

Inherit Freedom: There is certain freedom and independence about South African informal settlements. These self made communities express a sense of freedom. Under the Apartheid regime these settlements were perhaps one of the few areas where they were able to freely be themselves.

The negatives; **slum** living conditions

There are inevitably more negatives than positives when it comes to assessing informal settlements. Here although the negatives mainly concern informal settlements in South Africa, much is the same for many slums in other parts of the world

Intimate Ex-
pressive Col-
ourful Low
consuming
Intricate Net-
work Mixed Use
Inherit free-
dom



IMAGE. (WWW.TRAVELJOURNALS.NET)

Climate changes : people within informal settlements are considered to be most under prepared for climate changes and to be the most affected.

Poorly insulated: Most homes are made up of scraps and throwaways are often poorly insulated and therefor extremely cold during winter and hot during summer.

Devalued Land: Informal housing can decrease the value of its land and of property near by. Most informal settlements are on land that is deemed unsafe or of low value.

No sanitation: Very few homes have plumbing or water connections inside their homes. Toilets are often few and grouped together away from the units. Low number of water outlets per informal settlements.

Little voice: Although containing much of the population, many of these communities are uneducated and have little voice and opinions in public affairs.

No planning: Many lack access to public health, education and recreation services. There is often little to no open recreational space. Many are forced to use dangerous, neglected areas eg, along sides of freeways.

Overly populated: Density levels run extremely high. In many cases and within Cape Town, the majority of the cities population live within these areas.



Khayelitsha



Khayelitsha

Western Cape, South Africa

Khayelitsha lies within the province of the Western Cape and on the outskirts of the city of Cape Town. The maps to the right show the expansion of **Khayelitsha** over 2 year increments. The maps show mainly the expansion of formalized housing.

2005



2007



2009



2011



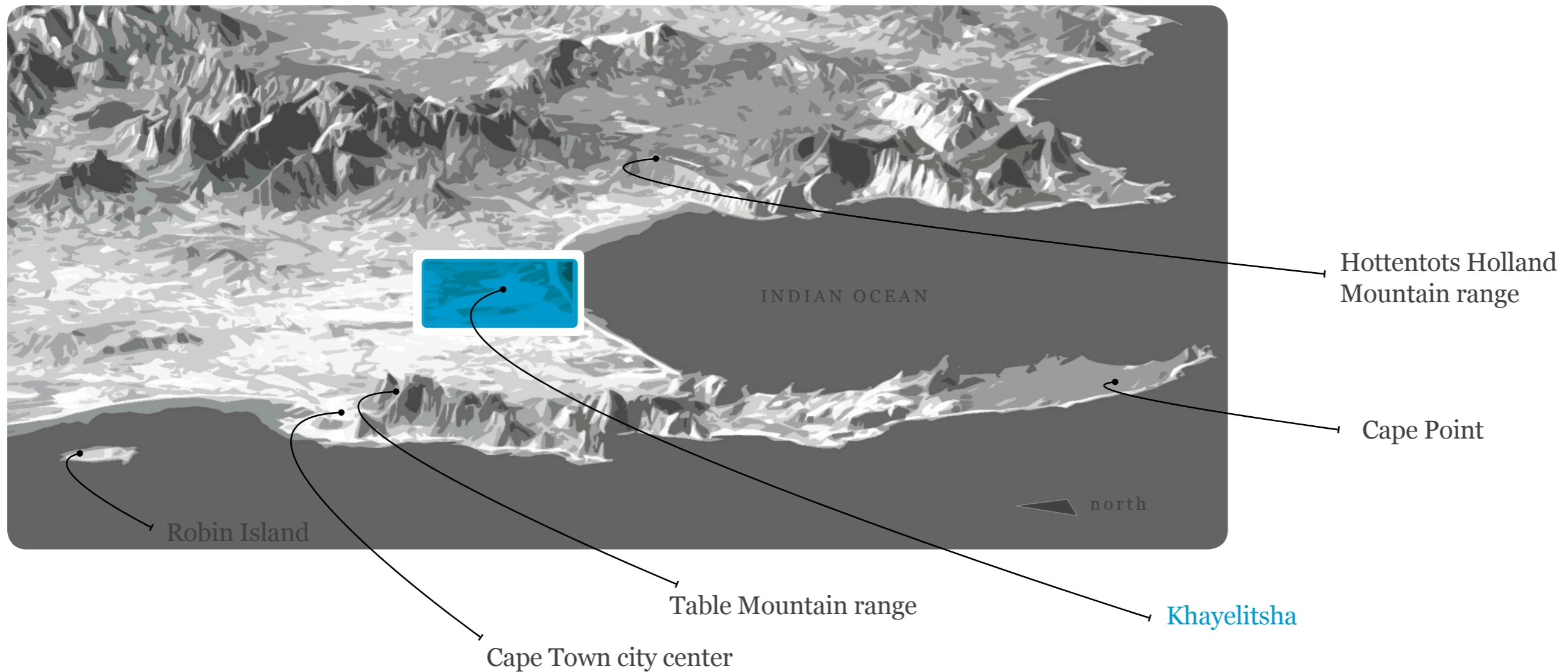

Khayelitsha, Western Cape

The blue highlighted area indicates the area in which the informal settlement 'Khayelitsha' resides. It is situated on relatively flat, sandy terrain, between two mountainous regions; the Table Mountain range extending from the city centre to Cape Point and the Hottentots Holland mountain range lying to the east. This flat area between the two mountain chains is what is known as the 'Cape Flats'.

The Cape Town city centre is situated westwards of Khayelitsha. Khayelitsha is bordered by the N2 national highway to the north and the Indian Ocean to the South.

Characteristics; **Khayelitsha** (the new home)

Khayelitsha is situated within the Cape Flats region. The region has a high water table and is prone to flooding. Winter flooding often occurs in this region.

Majority of the inhabitants are Xhosa decent, many have come in search of work from rural areas. Khayelitsha was established during the Apartheid regime. The word Khayelitsha means 'new home' in Xhosa

71.8% of households earn below the Household Subsistence Level/HSL (R1600/month) (URP, 2005).

64.4% of households, live in informal dwellings (URP, 2005).

Only 2% are over the age of 60(URP, 2005).

75% of the population is younger than 35 (QSJ Consultants, 2006).

Youth migrate to Khayelitsha in search of work. They make up the majority of the immigrants. (Yu and Nieftagodien, 2007)

The number of older immigrants has declined. (Yu and Nieftagodien, 2007)



TYPICAL XHOSA HOME LOCATED IN THE EASTERN CAPE. IMAGE (WWW.FLICKR.COM)



SELF MADE HOMES IN KHAYELITSHA. IMAGE (WWW.TRAVELJOURNALS.NET)



AN AREAL PHOTO OF A SMALL PART OF KHAYELITSHA SQUATERS. IMAGE (WWW.MAPS.AFRIGIS.CO.ZA)



BRIGHTLY COLOURED HOMES. IMAGE (WWW.TRAVELJOURNALS.NET)

Density, Units () per area

This sample study area is situated on the northern side of Khayelitsha (an alternative view can be seen on page 1). The area shows two contrasting housing situation (planned formal housing vs informal housing), living side by side. In terms of units per area, the difference between **formalized** and **informalized** can be seen below. All background images are identical in scale.

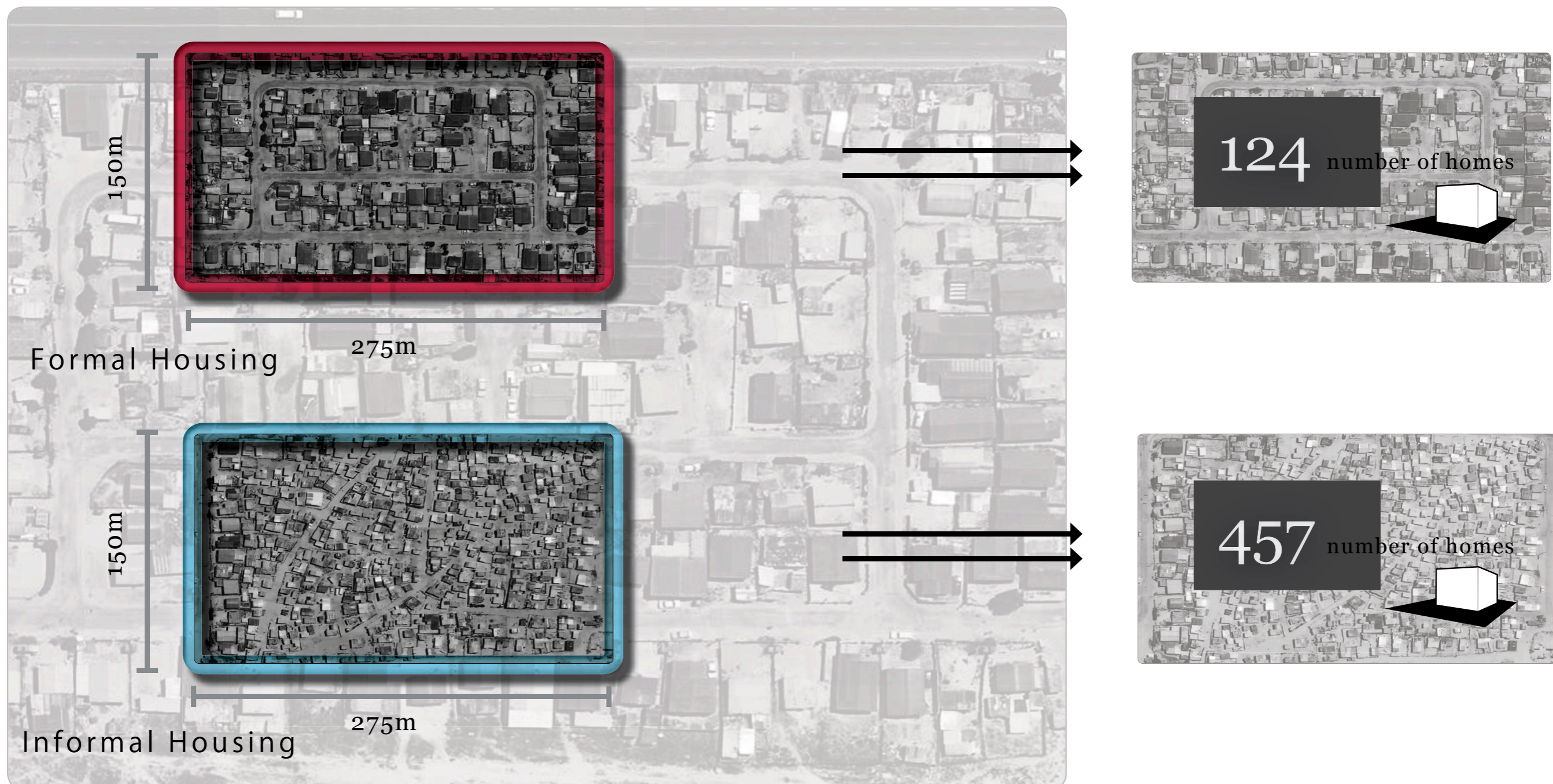

Density, Persons () per area

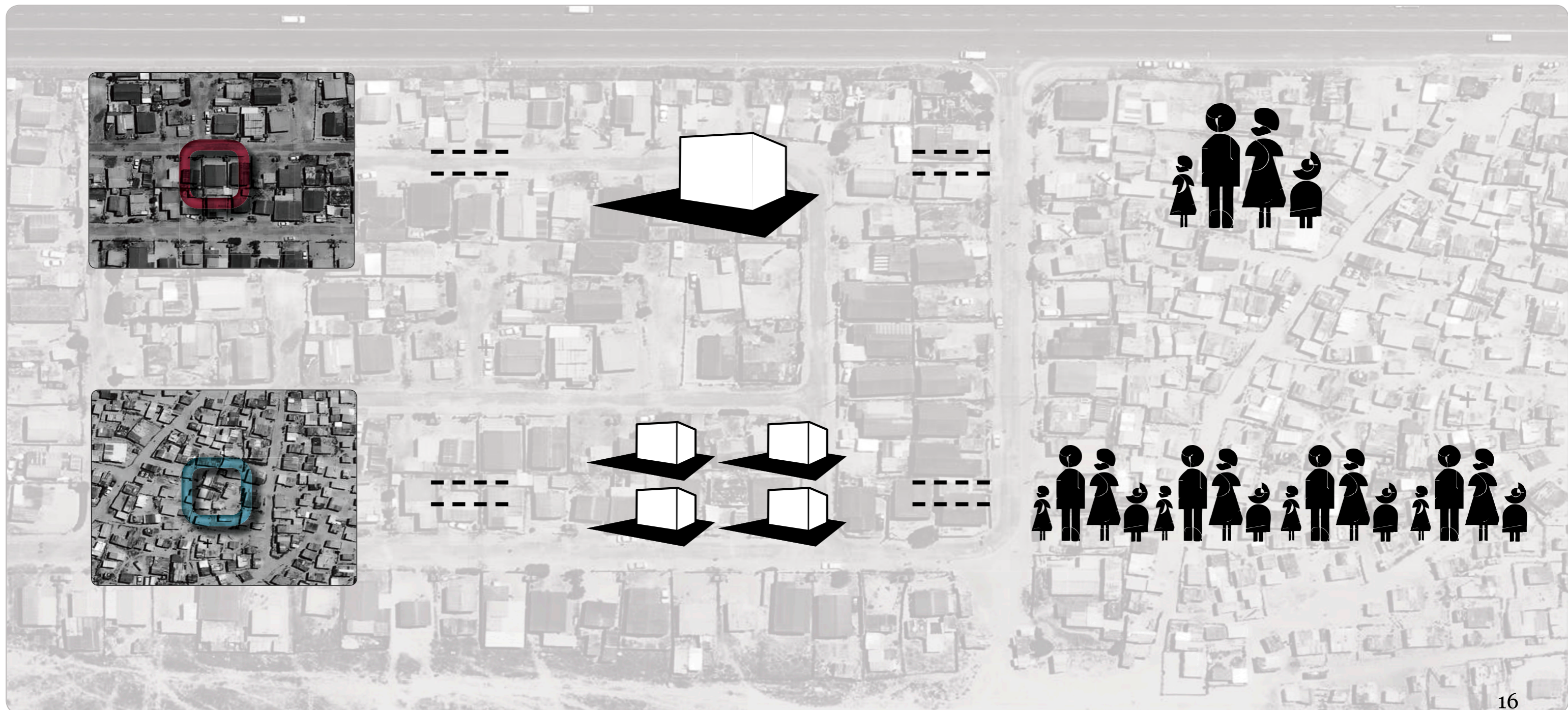

Comparing structures; Formalized vs Informalized

Formalized



RDP HOUSING IN KHAYELITSHA. IMAGE (WWW.MAPS.AFRIGIS.CO.ZA)

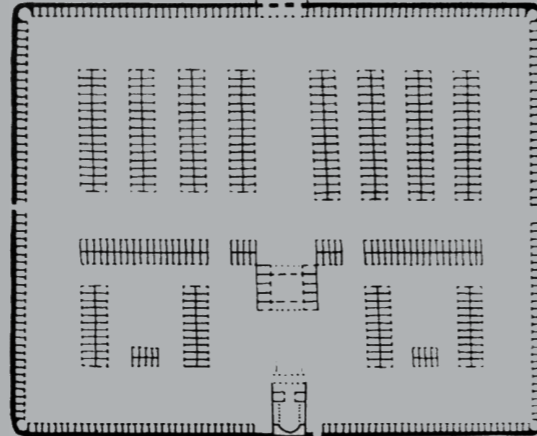

A TYPICAL ROMAN MILITARY COMPOUND. IMAGE (SUN ACADEMIA 2010)

A top down approach, RDP housing can be seen to have similar traits when compared to the ancient Roman military compound. This type of layout is considered insensitive to local specialities and unfit to trigger urbanity when used in a urban context (Sun Academia, 2010)

The planned structure here is set out rather in a calculative fashion and evidently over a short period of time. It has a certain authoritative quality to it. The units are placed in a fashion that makes it easy for authorities to control. The spacial qualities here are orthogonal, repetitive and rigid. This type of structure will in most cases have little to no community input, pleasing fewer when placed in an urban environment

Informalized



INFORMAL SETTLEMENT NORTH OF KHAYELITSHA. IMAGE (WWW.MAPS.AFRIGIS.CO.ZA)

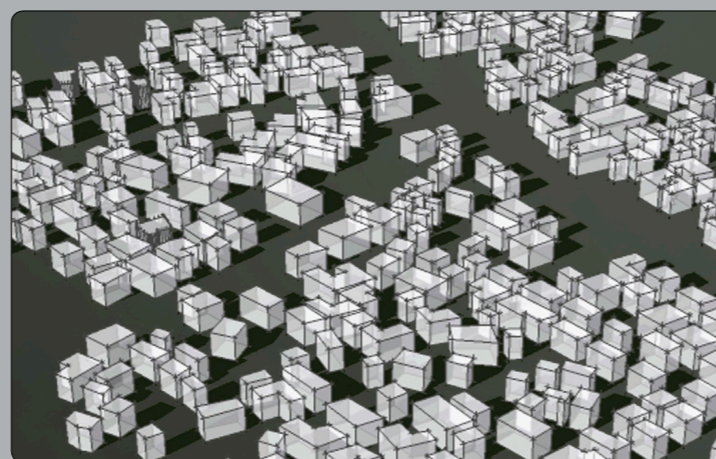

KHAYELITSHA INFORMAL HOUSING UNITS MODELLED

The image to the far left titled 'informal settlement ..' is a self made network of homes. The overall layout is organic and was forced to take into consideration the site elements as well as topography. This process has evolved organically over a longer period of time however, without any overall plan. There is a lack of planned facilities and designated shared open space.

What's also interesting to note here is when we take a closer look, we begin to see some order, a 'natural order'. Their homes are 4 side squares while certain areas have even adopted a grid layout system. This is most likely because of a density issue where as many homes are needed to be fitted onto the piece of land and the secondly, the need to erect a shelter in as short a time as possible. Its also visible that the migrants who live here have not used their traditional building techniques and are more influenced by local materials and the architecture of the surrounding environments.

Analysis, Khayelitsha informal settlement



ANALYSIS AREA

SCALE 1:10000

The informal settlement within Khayelitsha is highly populated with a dense network like structure of self made homes. The analysis to the right shows only some elementary attributes all of which are assumed since the availability of mapped information for Khayelitsha is hard to source or simply does not exist as of yet. A in-depth analysis study would require much more time and work since most of the data would have to be personally collect on site as much of this community is seems unofficially registered.

The central road that bisects the slum, notably the red line in the 'official circulation' map has become the economic spine. Many residents have opened up their own businesses here, running them from their homes. Like other slum areas, primary roads

become a hotspot to establish businesses due to the ease of access and high traffic. The main train line (orange line) connects with the major parts of the city. Trains depart for the city several times a day and the journey takes roughly an hour.

Many unofficial roads exit. Some of which are used by those who own cars. It hard to differentiate between vehicular roads and pedestrian pathways. It can be assumed if a car fits, then it becomes a road too.

There seems to be little usable open space for the residents when considering the sea of homes. It is unclear which areas are publicly usable by the residents and which are not. Never the less, the amount of open space per resident seem very little and scarce.



OFFICIAL CIRCULATION

SCALE 1:10000



UNOFFICIAL ROADS

SCALE 1:10000

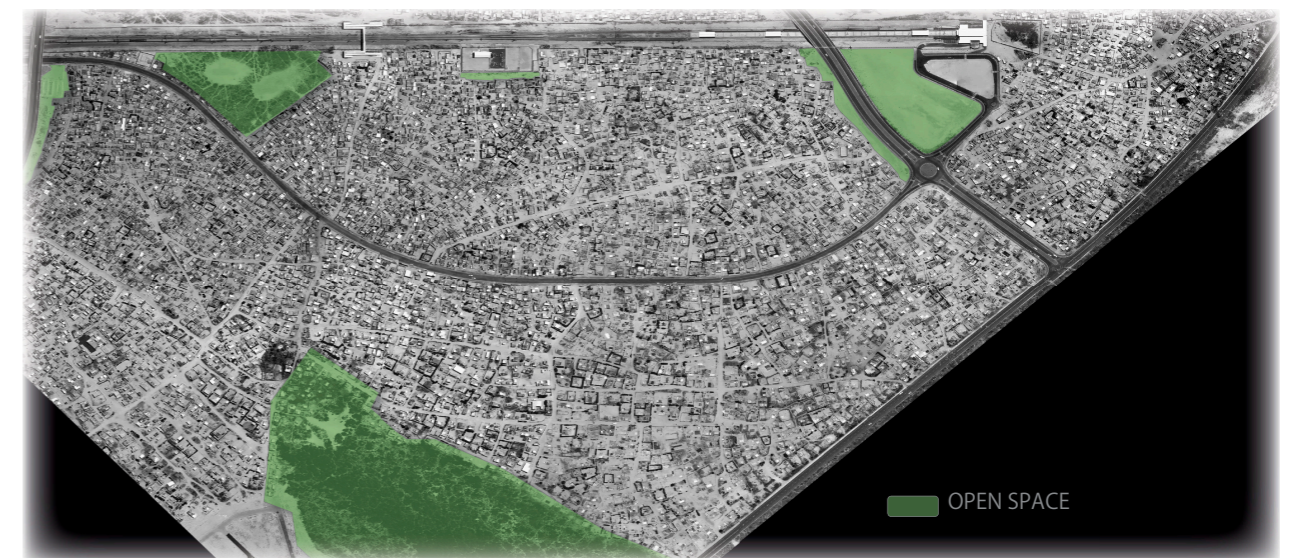

OPEN SPACE

SCALE 1:10000

Density, **Khayelitsha** informal settlement

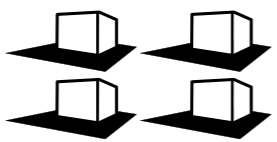
125 units 

x 4 person 

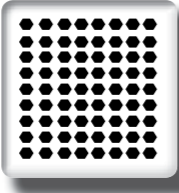
= 500 person per 100m² 

In 1 Km² there are **50 000** persons



DENSITY STUDY AREA SCALE 1:10000



Population numbers, comparisons

How dense is Khayelitsha? The graph to the right and the diagram below illustrate just how dense an informal settlement can be. (Population densities for Tokyo and New York are considered estimates and where taken from Sytse de Maat, 2010)

You may begin to wonder just how people can live in these high densities. Its hard for us to imagine since most of us who read this have never had to endure such living conditions.

The shacks of Khayelitsha are packed extremely tightly together, with very few square meters dedicated to each resident. What's even more interesting that most of Khayelitsha is single floor; there are few homes or building over 3 meters high. The small sizes of the units and how closene they are situated to each other is what makes up for such a high density.

Density numbers per 1 km²

The density of Khayelitsha is roughly 5 times greater than New York city

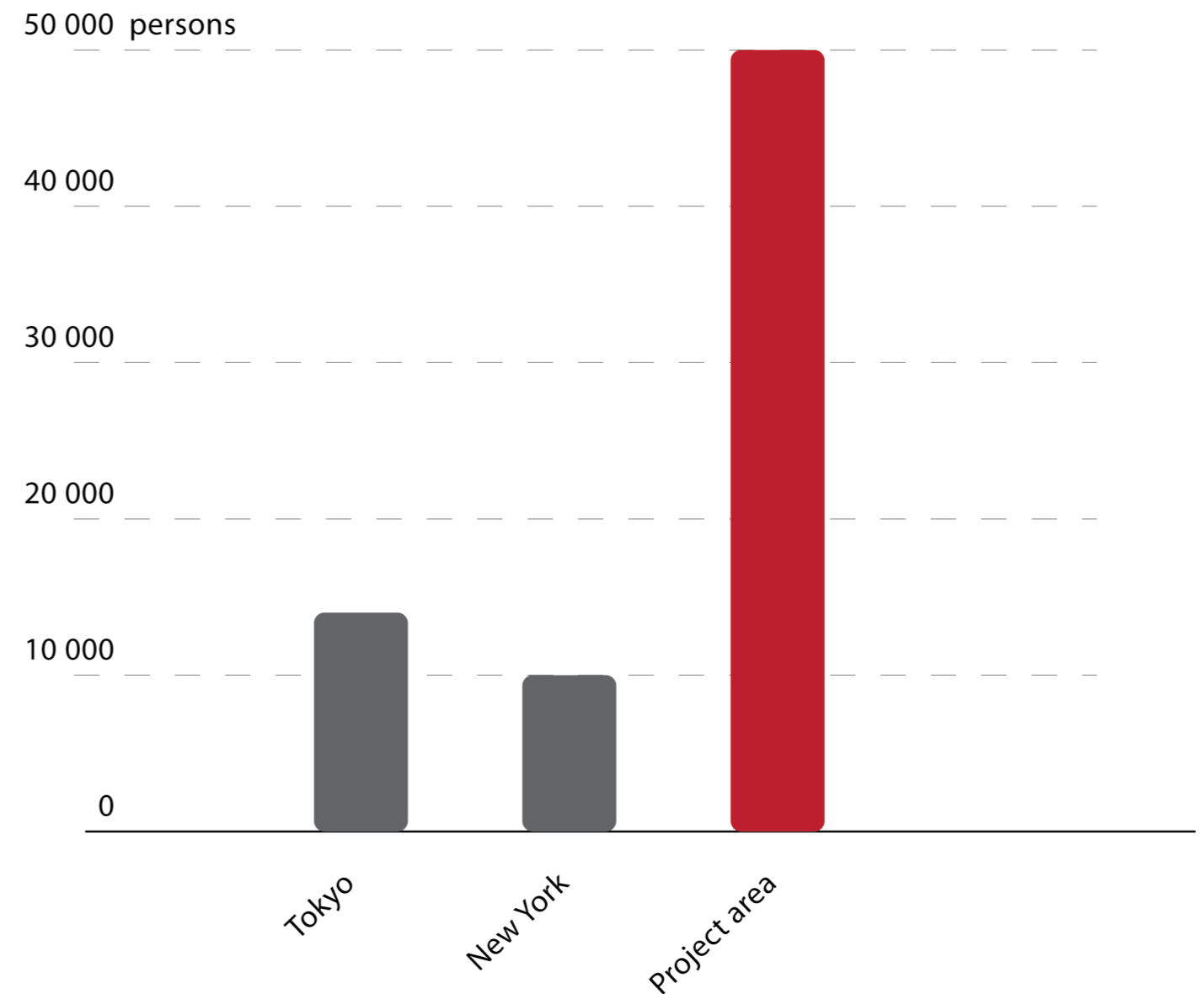

Density per 1 km²

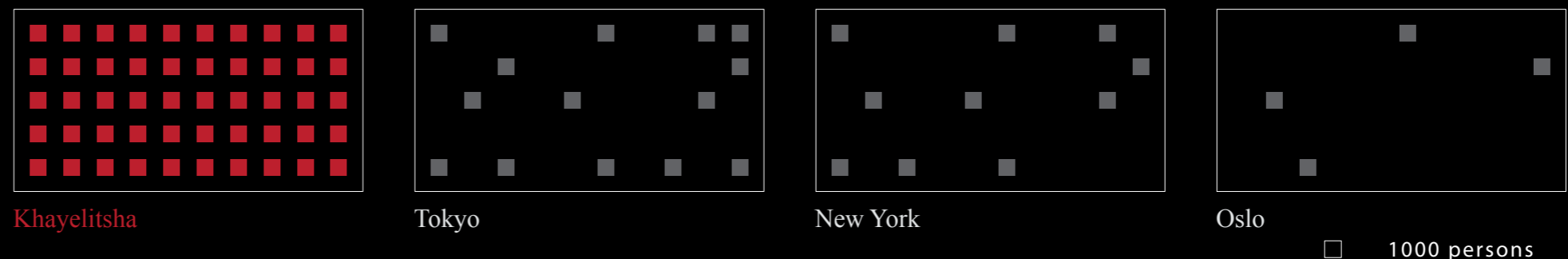



In-situ upgrade

Question; what should be done with Khayelitsha's informal settlement?

Should one consider redevelopment? What about the already established community with more than 60 years of history? How would the implementation of new sights and services and the new location of the homes affect the already established community network? The undertaking would be very complex and would require much planning, money and community input. In saying this, are there still other options available that would help ease the current problem without having a major disruption upon the community.

The area lacks many services, such as public transportation, access to recreational space, educational institutes, designated business areas, health services and adequate security. Many local residents have setup businesses inside their own homes (many were forced into creating their own income). Independent business are often common in slum areas. Many are faced of making a living for themselves when the economy and state are in a troubled situation.

Options:

What are the options? Many of the residents whom have jobs, work around various parts of the city and have commute times between 1 to 2 hours. Having said this, and noting the high population of Khayelitsha, it might be worth establishing more localized business. Making Khayelitsha more independent and less dependent on transportation; acting independently as a satellite city. The result would then eliminated the need for residents to commute over far distances, decrease stress on public transportation, lower emissions, and promote local infrastructure.

Having said that, one needs certain sights and services to improve the welfare of the residents, while trying to preserve the existing shape of the community. Simply placing sights and service without community input and careful planning can have a negative effect upon the community. The placement means residents would have to relocate. This is a big undertaking. These people are human beings like yourself and I and as much as we would not like to be

uprooted and simply place to a different home, neither would they. Careful planning and thinking needs to be taken when homes are to be relocated and new facilities are placed. It seems that it is almost impossible to not disturb some part of the community when one wants to establish services in certain area. There is little to no reserved land or space available among the homes. Therefor facilities would need to be placed on the outskirts where land has not been occupied.

“I’m shocked and disturbed by Luis Felipe’s calm assumption that we can create communities as easily as we can build houses” (Sun Academia, 2010)

Another hindering is where do these residents move to while there new homes and facilities are being built? Those receiving new homes, perhaps in the same location as their previous home, would only need to be temporarily moved. However this imposes yet another step and cost for the government. Its almost impossible to satisfy all parties, and it takes much time to considering the placment of the new homes and the location of the new services. It seems, to improve the living conditions within a township, a sacrifice will have to be made, and in this case, inevitably by a few residents.

Collective effort:

Deciding where certain facilities and services are to be placed should not be done by one figure alone. The majority of the decisions ultimately should come from a collective group; from on-site community involvement. This is due to the fact that the exact location of new facilities and services requires a far deeper on-site analysis and a high level of community input. In saying this, at this stage I cannot offer a masterplan for the Khayelitsha informal settlement area. I have little to no community involvement and the masterplan would be shallow and out of context

2 Possibilities:

The next two sections ('in-situ upgrade' and 'expansion') still however attempt to shed light on possible alternatives for Khayelitsha that will improve living standards while making housing implementation more efficient.

- In the first section, the project focuses on providing a housing prototype that will help open up more open space within Khayelitsha without de-fragmenting the existing community. The prototype is designed to appeal to both public and private persons as a possible alternative to the current standard RDP home provided. Once again, the idea here is to try preserve their lifestyle and the unique community that exists there today.
- The last section of this thesis displays various neighbourhood models that could be used in future formalized settlements and that of expanding Khayelitsha. Consideration has been taken to the environment, natural resources, costs, the new residents and sustainability. They are designed to be appealing to both the RDP and those receiving the homes. In both sections, community members are encourage to take on the work themselves and the government should be encourage to employ local residents when implementing work.

A d a p t a b i l i t y

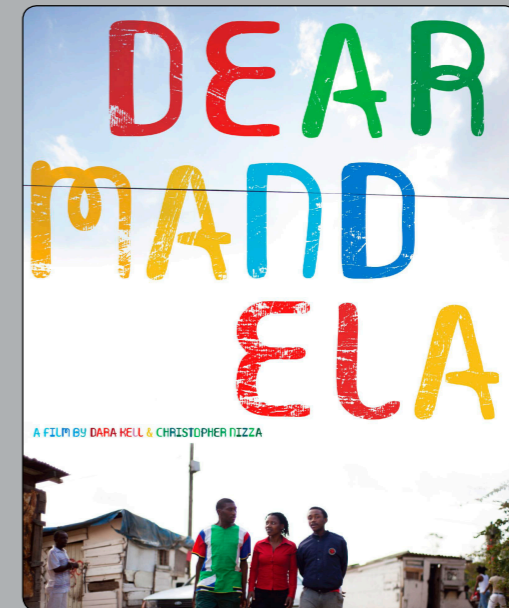

DOCUMENTARY CONCERNING INFORMAL SETTLEMENT EVICTION IN SOUTH AFRICA. (WWW.DEARMANDELA.COM)



A CAMPAIGN ORGANIZATION FORMED IN 2000 AIMED AT FIGHTING EVICTIONS. (HTTP://ANTIEVICTION.ORG.ZA/)

Concept; providing it **part build**

One of the main issues faced with housing the poor is simply creating enough homes in a timely fashion. That is to say, building enough homes while meet the growing rate numbers. Previously to satisfy this, the homes were often built quickly and cheaply however the quality was often poor.

How do we fix this then?

What if only part of the home was built. But of higher quality; half the house, less time and all for the same price. All the parts that are deemed essential for adequate living or require craftmanships would be supplied and built. The rest is to be done by the resident.

The idea here is to provide the basic skeleton of the building, then they build the rest. In other terms then get to move their existing homes onto the structure, or the parts they want to keep. In essence it becomes a renovation with them being the architects. They personalize it, they create its value, they decide where the walls go, they decide what to keep from their old home.

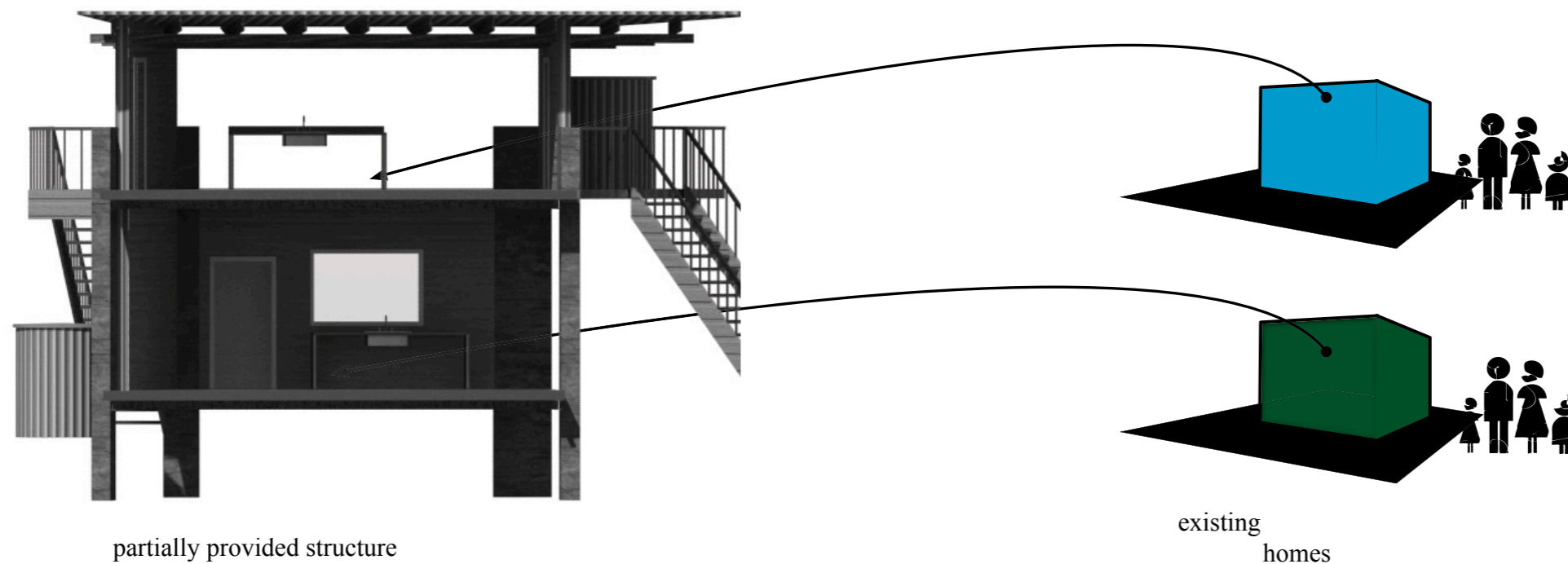



Khayelitsha: the new structure accommodates their existing homes

Why is this better?

it's personal. lets them be involved.

helps **increases open space.**

larger floor space.

homes are **flood tolerant.**

property increases in value - appreciating asset

Individual homes in townships are often colourful and personalized. The habitants made their shack a home. They took what little they could find for shelter and transformed it gradually into their a home. Despite the poor quality of building materials and surroundings, it is important to note that it is still a home. These shacks are extremely personalized and unique.

Since the RDP has struggled meeting the backlog of houses needed and of adequate quality, why not provide just half the home but now of better quality. Putting more effort in quality while still meeting quantity demands as there is only a need for half a house. The units were designed not to replace the homes. They were designed to accommodate them.

This translates to a roof over their heads and stable floor, sanitation and plumbing to improve health, kitchen and water for food preparation and cleaning.

The structure is designed in a way to be built cheaply, quickly, while adding improved adaptability to future environmental changes. They are allowed to customize their new homes on the floors provide and under the roofs provide. They are able to transport their shacks onto these floors, **taking their home with them.** The outcome is improved standards of living. This also eliminates the need for further input in creating individualized units, saving money while maintaining the unique and personalized community.

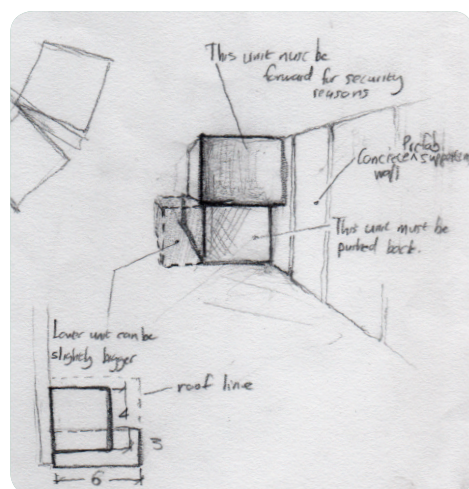

THOUGHT IN PROCESS

In this situation I asked "what is it exactly that would help improve the residents living standards?" What are the elements that would improve quality of life? In this situation, the basics are

- Shelter
- Sanitation
- Water
- Food preparation



Dimensions:

The structure is made up of two floors. The bottom floor has a total of 36m² of total usable space. The second floor has a total of 42m² usable space. Residents are allocated a floor and a roof. Each floor is dedicated to one owner or one family. Larger families may use both floors.

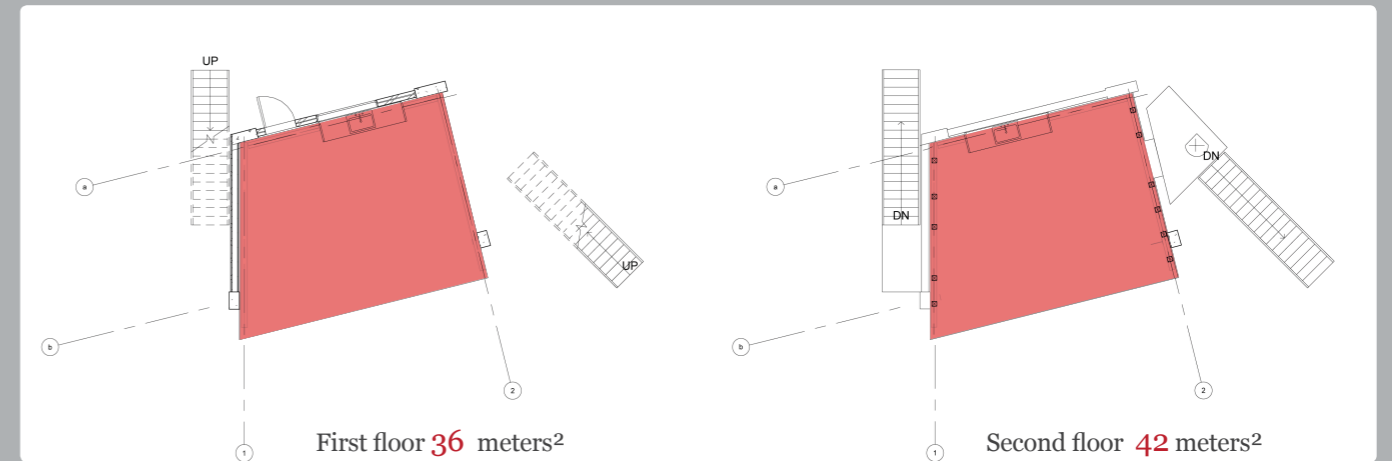

Floor dimensions

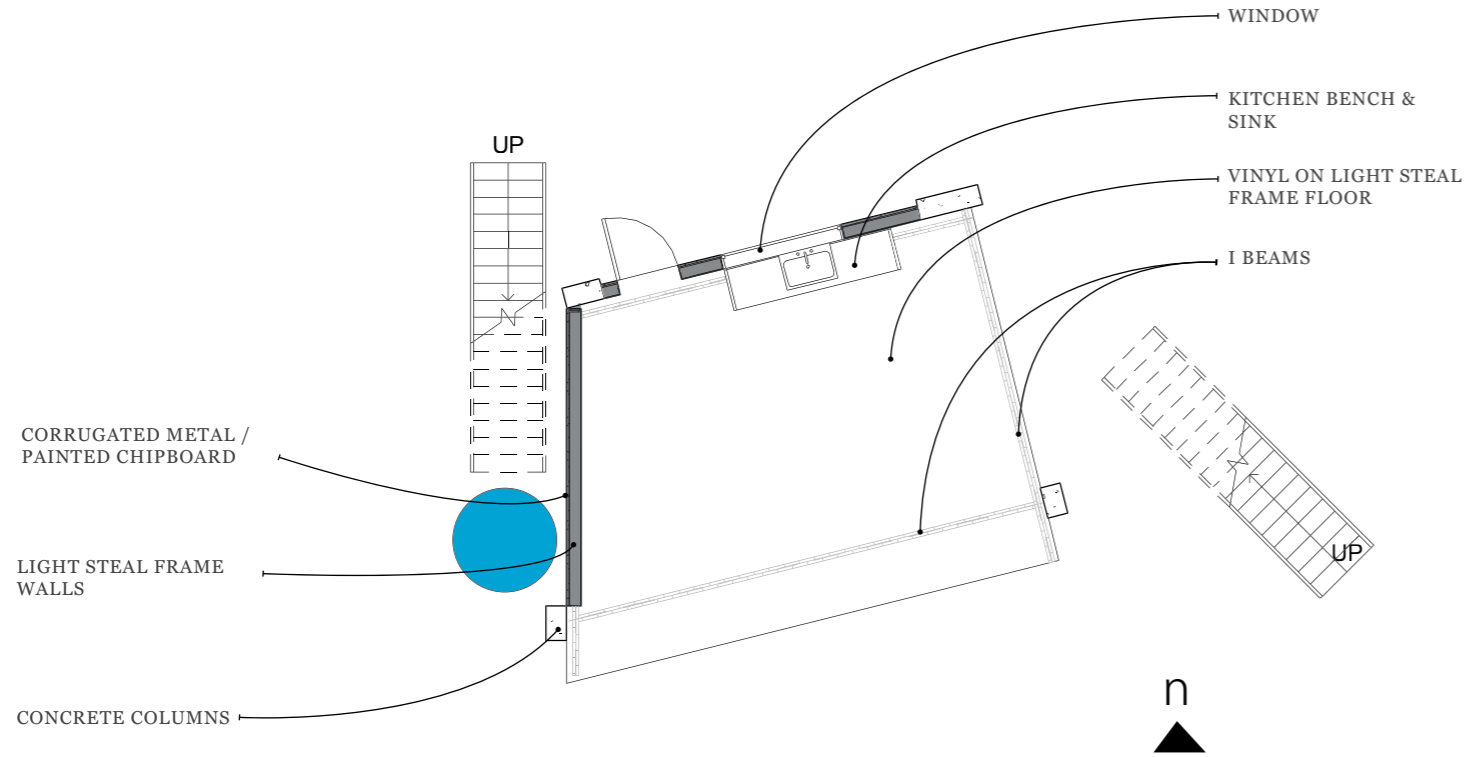

First floor

scale 1:100

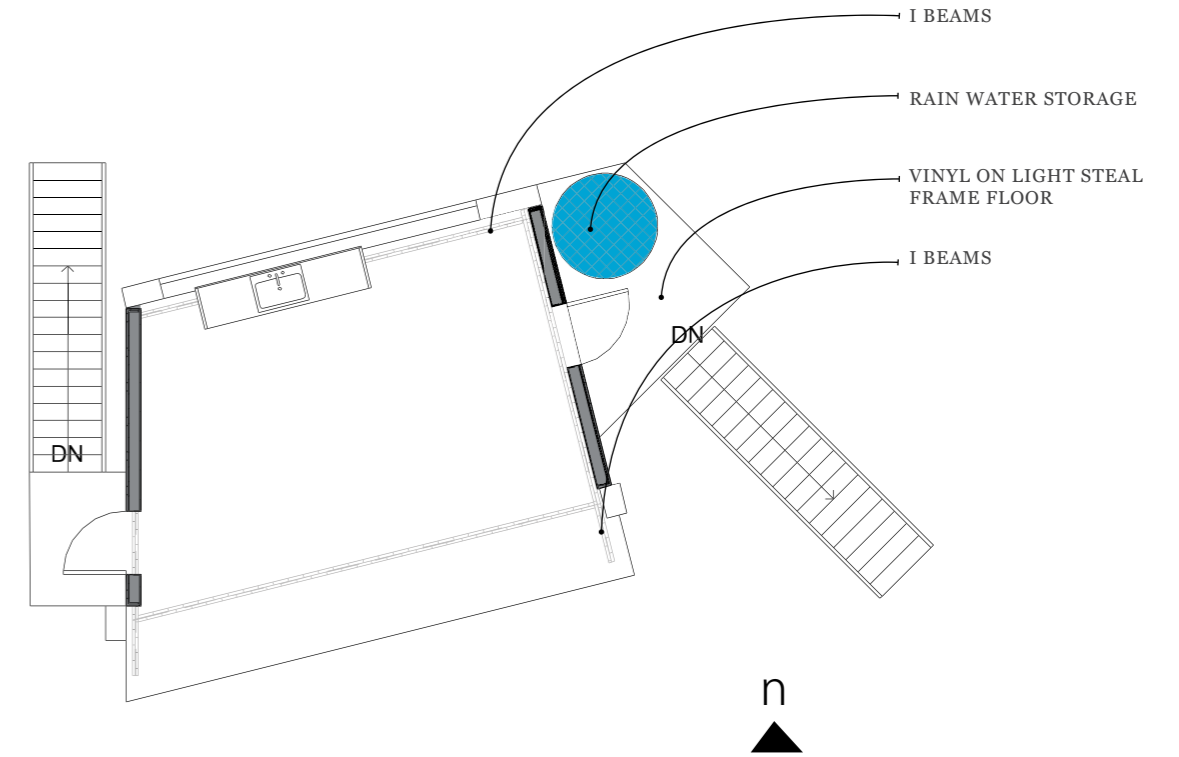

Second Floor

scale 1:100

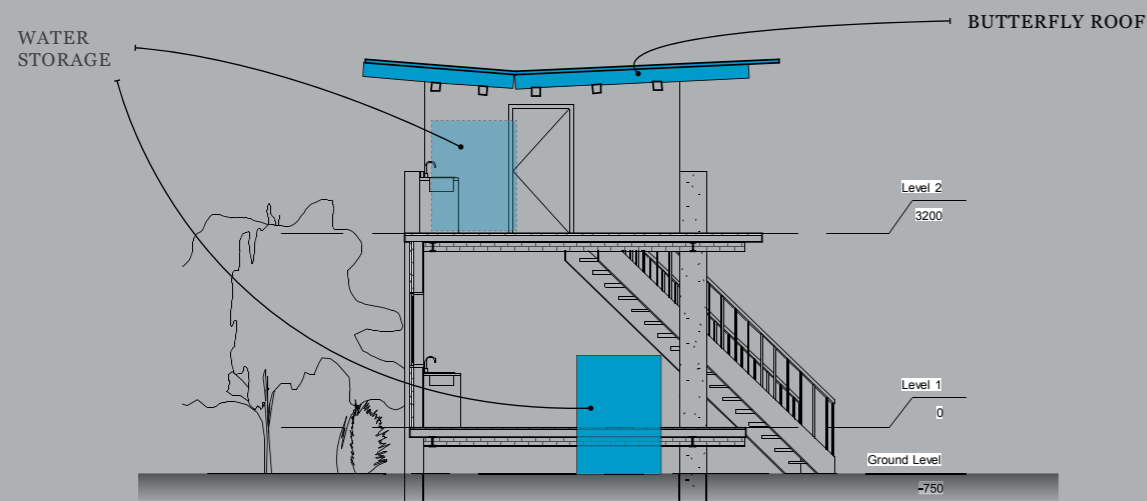

Water & solar catchment

scale 1:100

The top unit has a butterfly roof attached which is supported by east and west walls. The roof is shaped to aid rainwater catchment while accommodating improved solar exposure for the solarpanels. The butterfly roof is supported by the two walls. The walls and roofs are dynamic as such when the floors are raised, so too are the roofs.

Each unit will be equipped with a single tap and sink, with the drinkable water provided by the municipality. Plumbing for grey water will also be provide. 2 forms of electricity will available, each with its own outlet. One from solar generated power and other from the municipality. Electricity generated from the solar panels will be free. Power used from the municipality will have to be paid for by the tenant.

Levels:

The first floor of the structure sits 750mm above the existing sand surface. This ensures the homes are safe from yearly winter flooding.

In addition the units are designed for the floors to be raised in case of future sea levels rising. The floors are support by beams which attached to the 4 concrete columns. The columns are depicted in white in the image to the right.

The bottom unit has the possibility of using the underside of the top units floor as its roof. This is recommended as this minimize heat and cooling loses. However if the tenant chose, he or she may establish their own roof at a lower height. The established height provide between the 2 floors is 2.75 meters.

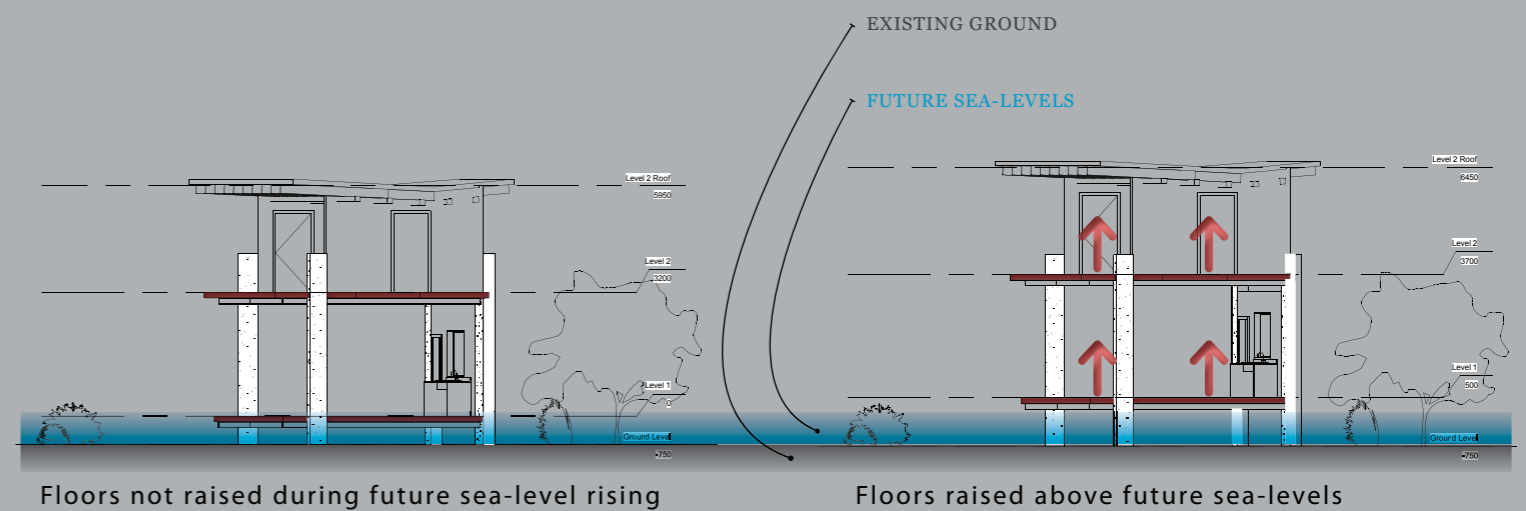

Future sea level rising

scale 1:100

Northeast view

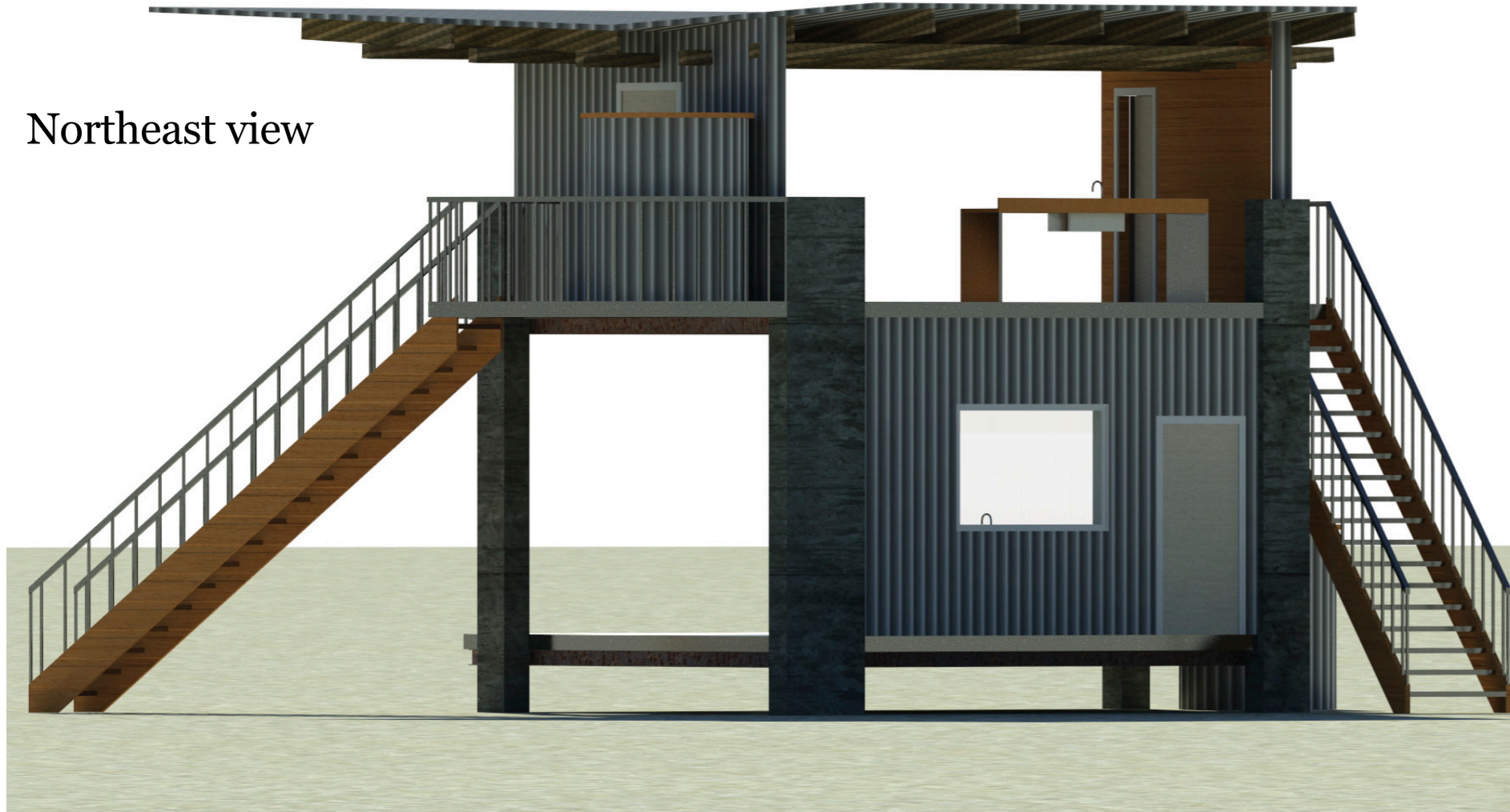

Structure; without homes

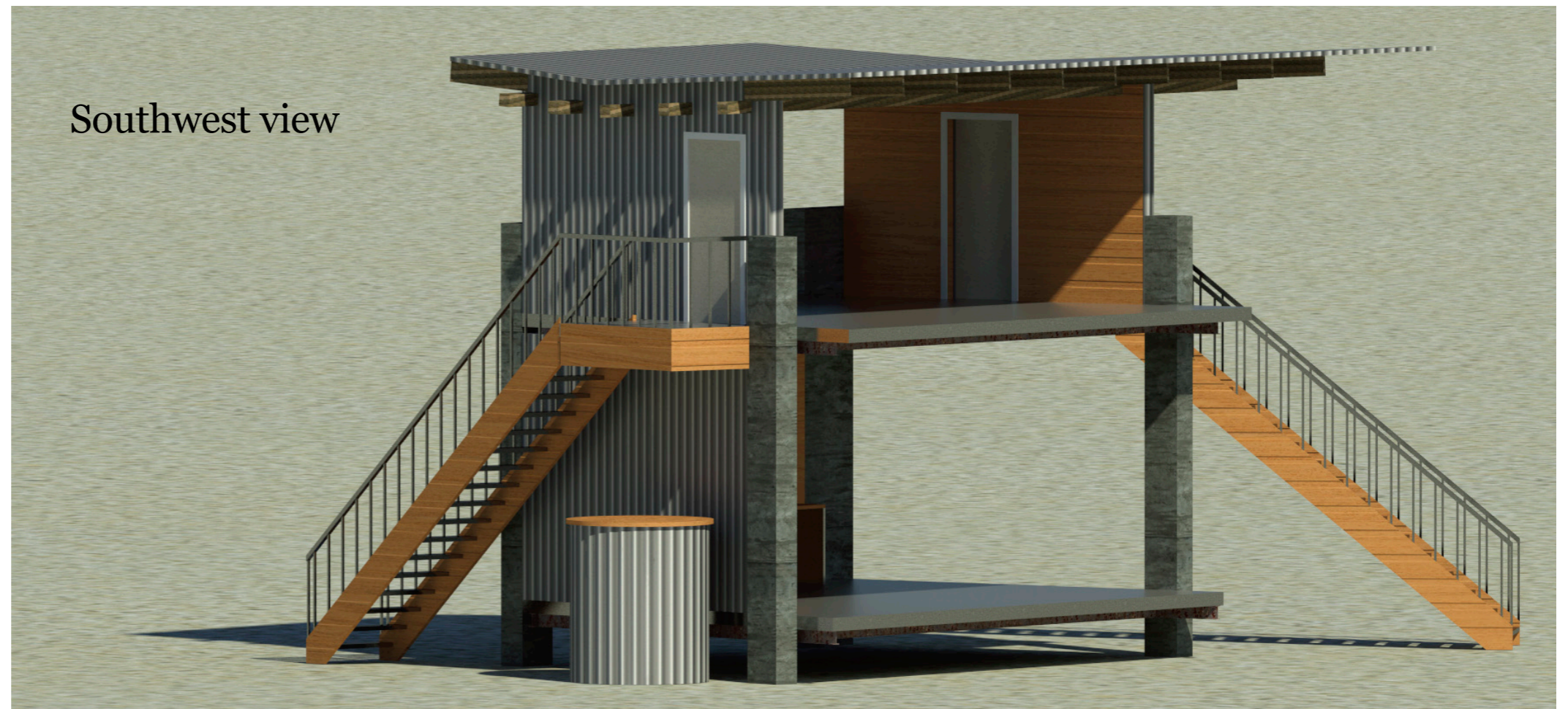

Structure; with homes

Northeast view





Southwest view

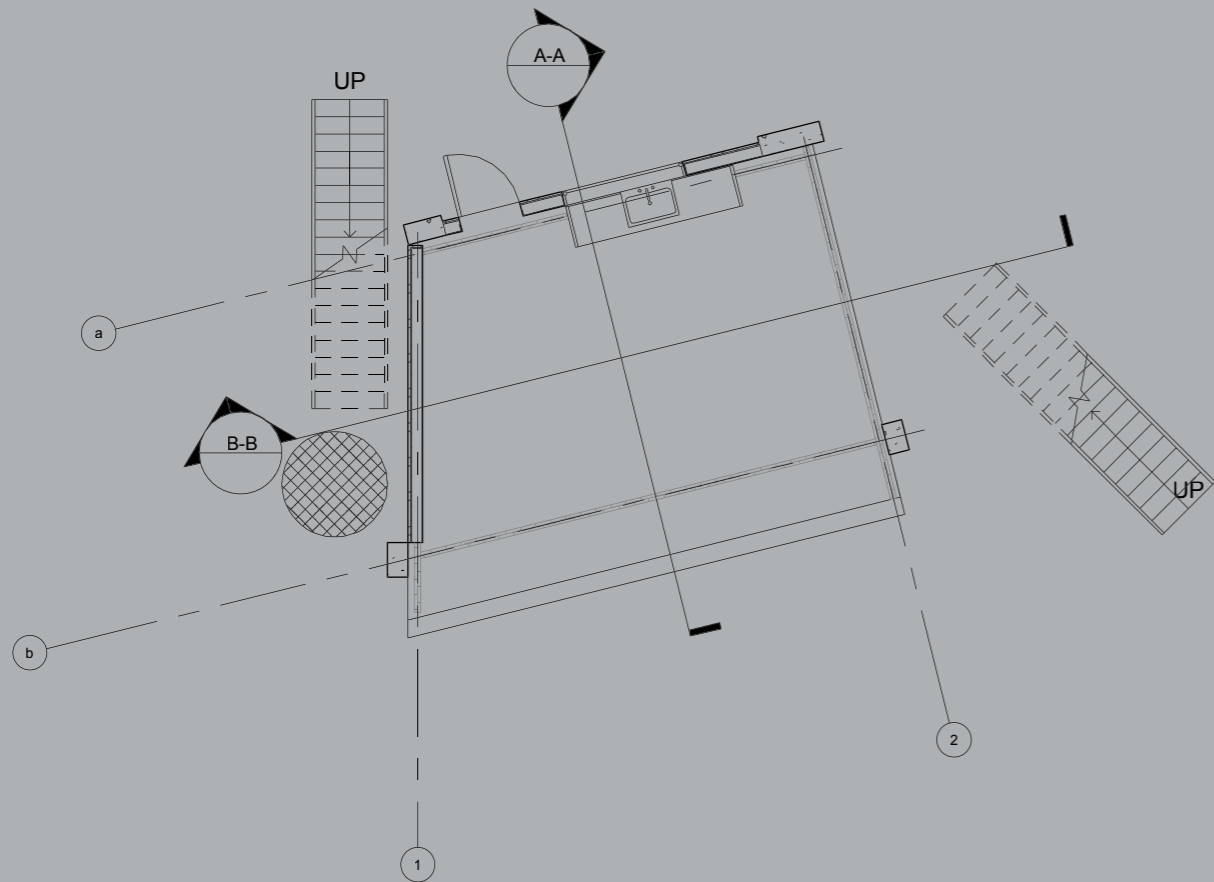

1 Level 1
1 : 100

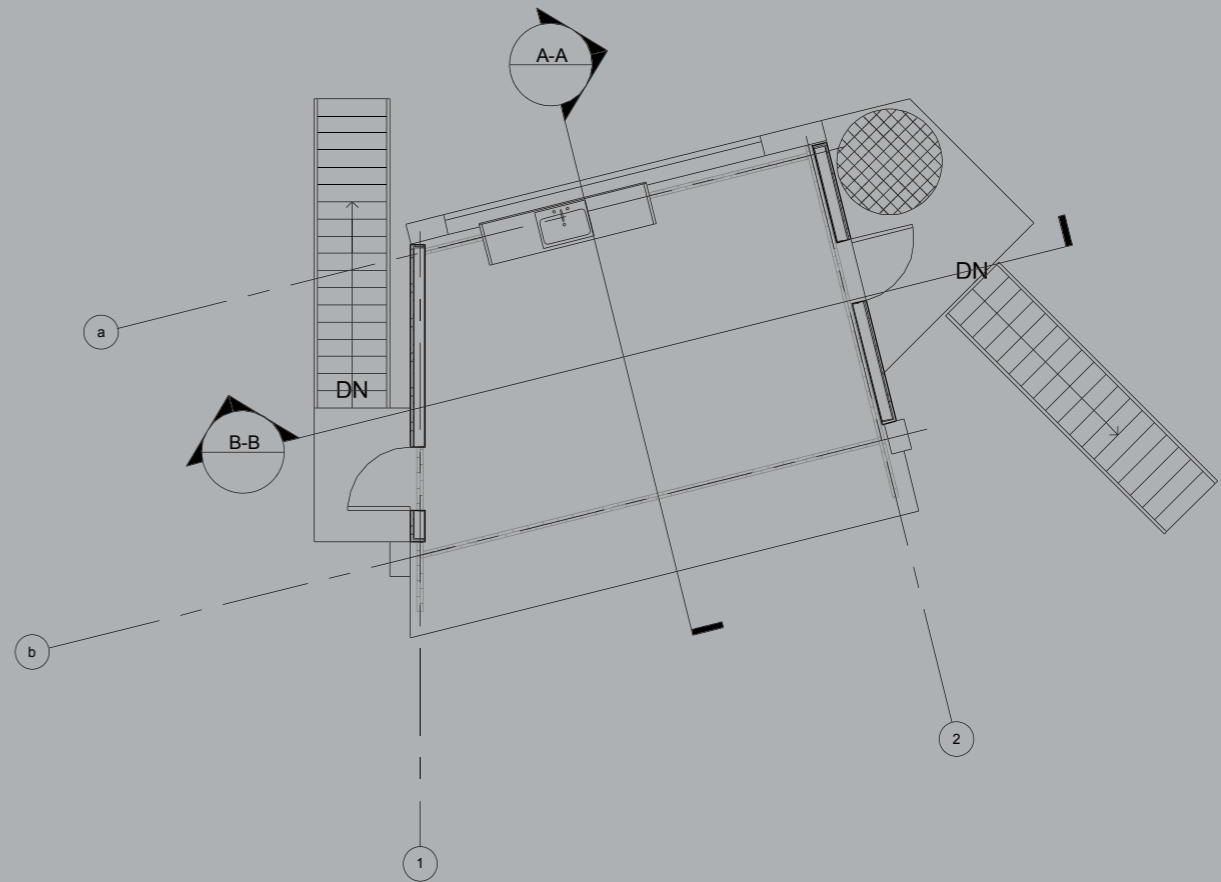

2 Level 2
1 : 100

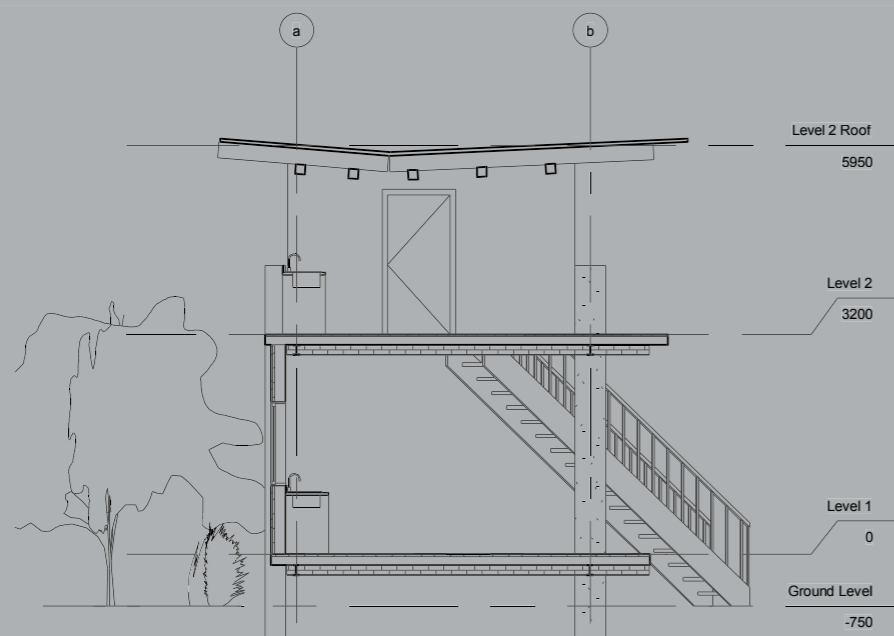

1 A-A
1 : 100

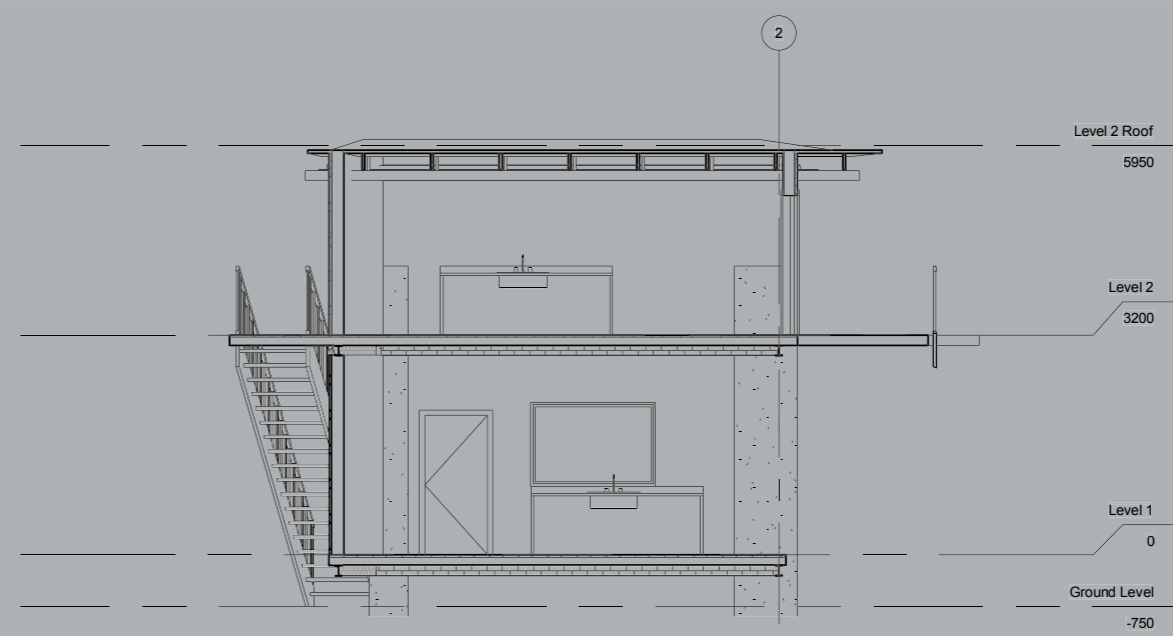

2 B-B
1 : 100



Expanding

Basis; **new settlements**

This next section shows various arrangements of the prototype. It's meant to show the various possible formations of the part built structure. These formations or community cluster can be used when planning new formal settlements.

The first part of the section shows brief plan views of how the homes could be arranged. The last part is a more detailed formation that could be used in the event that Khayelitsha would need to expand

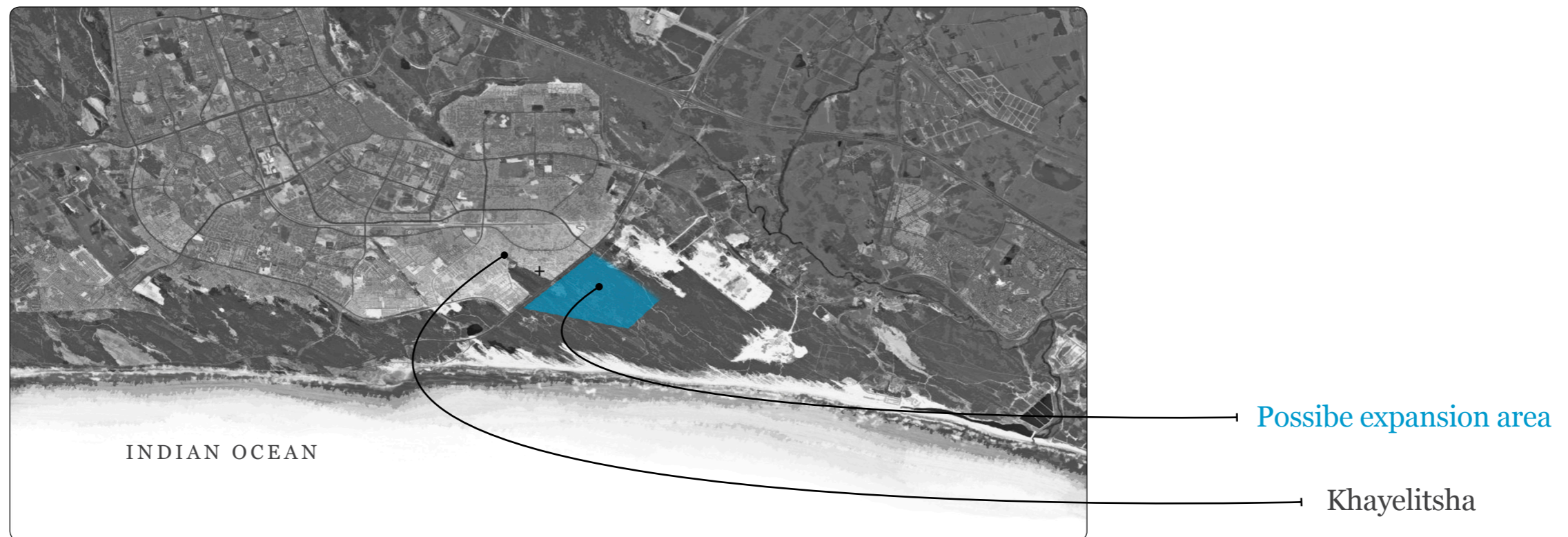

Unique spaces; various clusters

The plan views to the right show various adaptations of possible layouts for the expansion or establishment of formal settlements. These are just a few examples of possible arrangements.

Here the part built structure from the previous section is used unchanged; reducing cost and speeding up construction. The prototype is simply reflected and rotated to create varying clusters of homes. Elements such as the external toilets and stair access to the top apartments will however need to be adjusted according to the cluster type.

The advantages of using various layouts when planning formal settlement is the possibility to create unique interactions and spaces. Through this method one is satisfying a broader range of inhabitants wants and values, appealing to a large range of individuals. The clusters can also be used according to certain site restraints and topography.

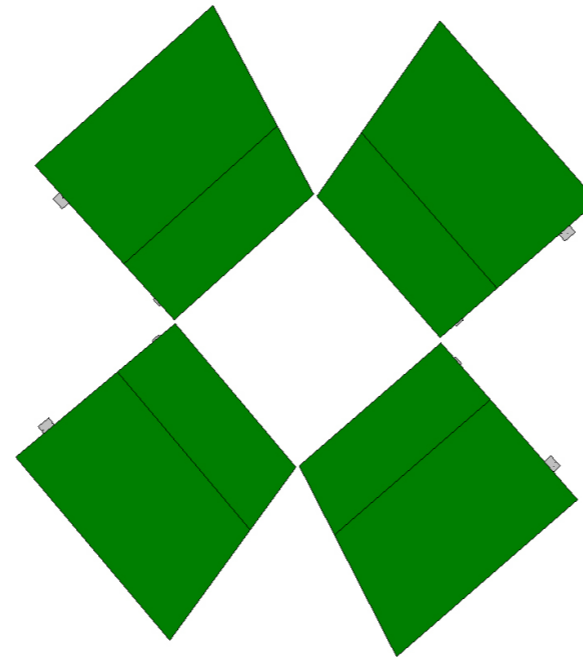

Cluster 1: Closed courtyard

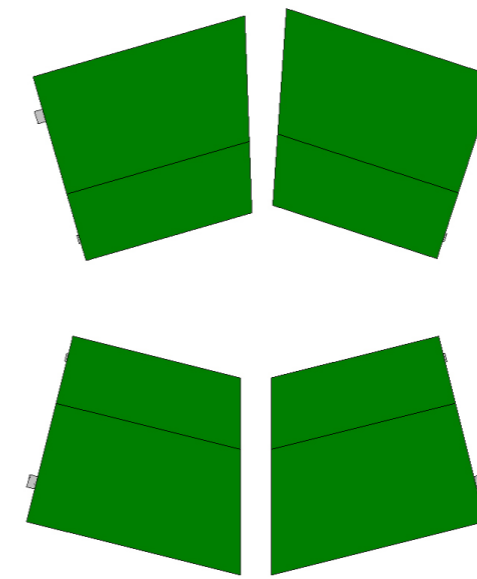

Cluster 2: Open courtyard

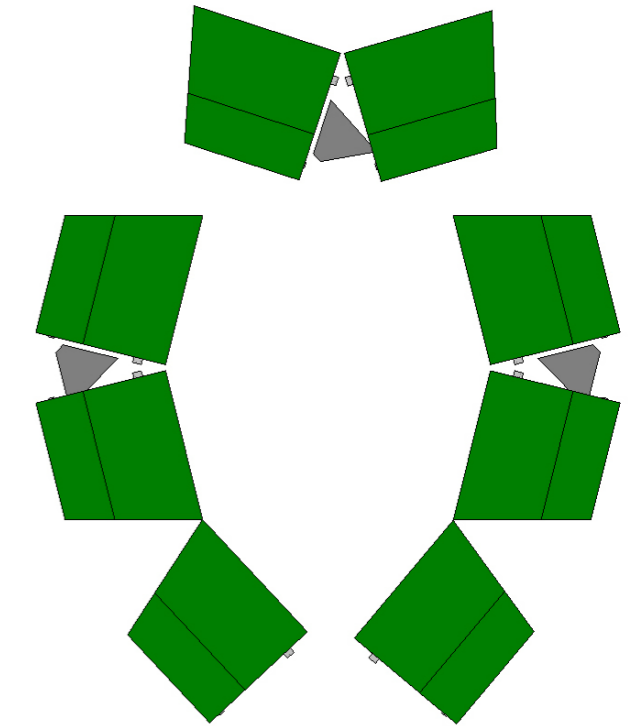

Cluster 3: Open courtyard with multiple access points

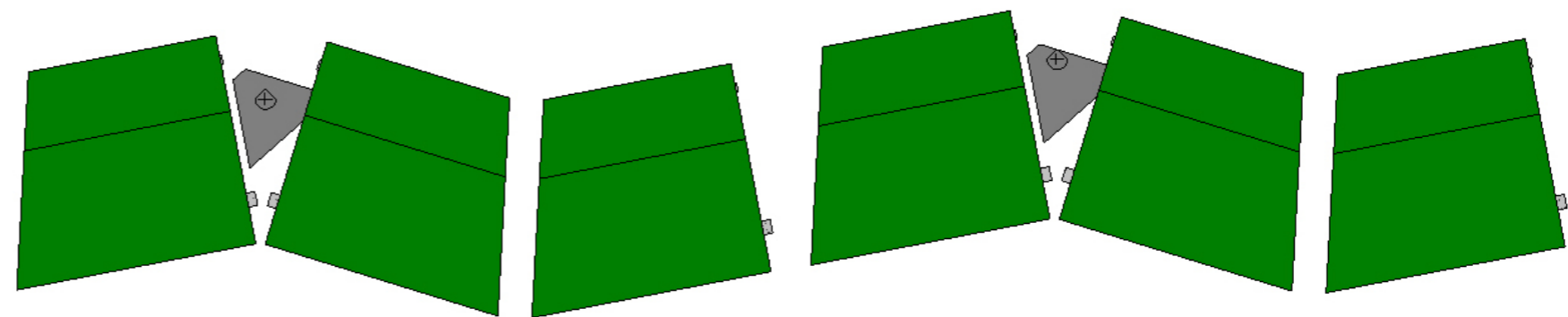

Cluster 4: Strip housing; possible placement along corridors and edges

The hut; cluster 5

One of the main ideas behind this 5th alternative is to promote the sense of community through a shared environment and while creating awareness to resources. In all 5 of the cluster examples, the housing prototype from the previous section is used.

In this example the prototype is mirrored at a certain angle, thus creating the circular shape resembling the shape of the traditional Xhosa mud hut, a shape many of the Xhosa people of Khayelitsha can relate to.

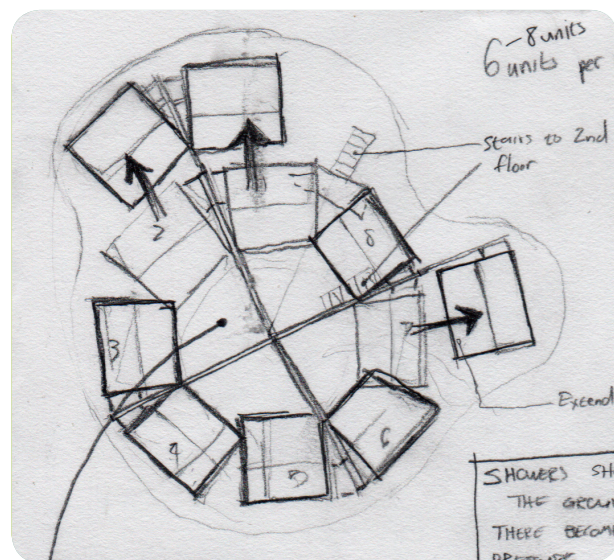

HOMES PLACED IN A CIRCULAR FASHION

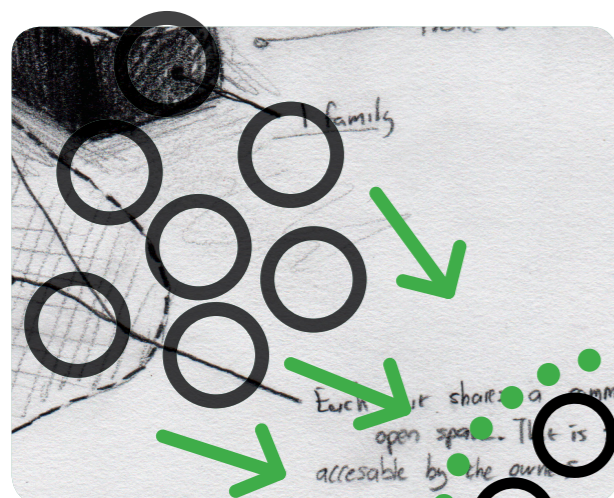

BRINGING SCATTERED ENTITIES TOGETHER. UNIFYING THE INHABITANTS

Interior space:

- The interior courtyard are to serve as a community shared space where by all the units cirumferencing the area have a right to use the space. The courtyard is semi private space, and therefor to be taken care of by the tenants.
- Laundry facilities (basins) and toilets will be provided in these areas and all to be shared by the units.
- All grey water from the unit will be stored beneath the stairs on outer side of the homes. A larger reservoir in the courtyard will be used for rain water catchment from the roofs. The rain water is to be used for washing of clothes and water of courtyard plants and vegetation.
- Laundry basins are provided and placed beside the rain water reservoir inside the courtyard. All grey water (from washing, hygiene, cleaning dishes) from within the units will be fed down to the toilet reservoirs and used for flushing. When there is not enough grey water from the units to flush the toilets, the rainwater will be used or lastly municipal water from inside the units
- The only place where there will be municipal water will be in the units themselves. There will be no municipal water in the yards. This is to encourage residents to use the captured rainwater and learn the important resource of water.
- Both solar and municipal electricity will be provide, and in the same manner as in the first section.
- The bottom units have the option to personalized the area outside their unit. Planting of grass, trees and establishing of low borders is allowed. The top units do not have designated garden areas but may past of their floorspace for a balcony. Both top and bottom units have access to the courtyards

Got water; more independent

The Western Cape province of South Africa is considered a dry region with an average of 350mm rain per year. It is the second driest region in South Africa (Enviro-Info, 2001) with droughts and water warnings happening every few years.

With an already high population, its important to make use of what water one can get ahold of. Capturing rainwater is a simple method and can help less the stress on local damns and municipality supply lines.

Here the project attempts to harvest rainwater and use it for none consuming activities, lessening the dependance on piped-in water while becoming more independent and prepared for future climate problems

Here the project estimates how much water is need just to ensure adequate sanitation.

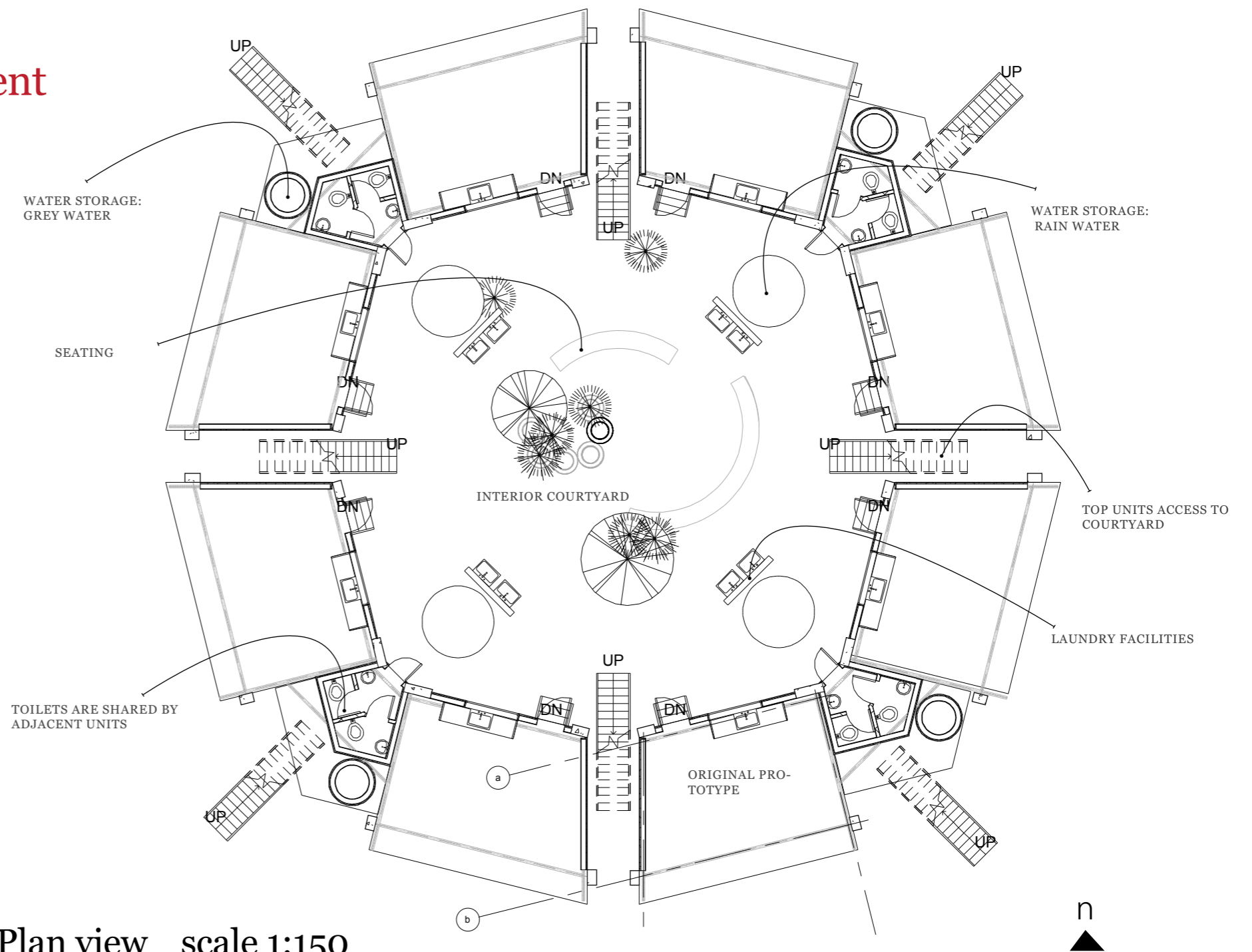

Plan view scale 1:150



How much water do we need?

A typical dual flush toilets use 3 litre to flush liquid waste and 6 Litre's to flush solid. Lets say the average person visits the toilet 3 times a day. (2 x for urine and 1 x for solid waste). That translates to 12 litres of water used each day per person.

Each 2 level unit uses approximately 96 litres per day (12 litres x 8 inhabitants)

Corresponding to 2 976 litres each month (96 litres x 31 days)

This translate to atleast 35 712 litres each year (2976 litres x 12 months)

Now we know how much we need.

How much water can we capture?

Since we know the average rainfall per year in the Western Cape is 350mm we can multiply that against the dimensions of the units roof (55m²). We then multiply this number by 90% as only 90% of water from your roof will make it into the tank, 10% is presumed lost due evaporation etc. After do that we find out that the part built structure will provide us with 17 325litre of water each year.

The rain water captured by the roof alone would supply just over 50% of the water needed for the toilets

Where do we put the water?

In tanks. The month with the highest amount of rainfall is June with 140mm. With 2 roofs (110m²) serving one tank, the minimum size tank one would need is 13 860 litres. 4 units share each tank. Each unit use 1488 litres each month, therefor 4 units would use 5952 litres every month.

So for the highest rainfall month June, one would need a tank with a minimum capacity of 7908 litres to hold excess water (13 860 - 5 952). These tanks/reservoirs can be seen in the courtyards.



The units occupied by the residents





View of interior courtyard

Concluding thoughts . . .



It is perhaps through being open and considering various possibilities that one can begin to solve some part of the housing problem. The approach is perhaps what needs to be changed and its hopefully through change that a better program could be implemented.

In this thesis, I've hopefully created awareness of the current issues regarding informal settlements in South Africa and therefore opened the possibilities to change and better living standards for those in need. Looking back this could be perhaps the main aim behind the project.

The concepts and ideas you were presented with earlier are mere possible attempts to addressing the problem and I hope by seeing these alternatives, better ideas and more possibilities come forth and be undertaken. There is a large portion of the world's population living in sub standard conditions and it is them who need the ideas and support. Could it be that they are the ones in most need of our services?

Finally it's perhaps through creating the means for understanding that will provoke change . . . [change for the positive](#).

If you have any thoughts, ideas or comments please feel free to contact me at andrewNblair@gmail.com

References

David JC MacKay, 2009, *Sustainable Energy - without the hot air*. England: UIT Cambridge Ltd

Department of Human Settlements, 2009a. *The National Housing Code: Simplified Guide to the National Housing Code*. (Retrieved 10.12.2011, < <http://www.dhs.gov.za/index.htm>>).

Department of Human Settlements, 2009b. *Housing Project Process Guide: A process guide for the following National Housing Programmes*. (Retrieved 1.12.2011, < <http://www.dhs.gov.za/Content/Documents/Housing%20Project%20Process%20Guide.pdf>>).

Enviro-Info, 2001. *Rainfall*. (Retrieved 3.9.2011, < <http://www.environment.gov.za/enviro-info/prov/rain.htm>>).

Helene Le Roux, 2003. *RDP houses lacking in energy efficiency*. (Retrieved 16.9.2011, < <http://www.engineeringnews.co.za/article/rdp-houses-lacking-in-energy-efficiency-says-company-2003-06-06>>)

Marie Huchzermeyer, 2009. *Development Southern Africa: The struggle for in situ upgrading of informal settlements: a reflection on cases in Gauteng*. London: Routledge.

QSJ Consultants & Unit for Religion and Development Research, 2006. *Socio-Economic Profiling Of Urban Renewal Nodes: Khayelitsha And Mitchell's Plain*. (Retrieved 19.11.2011, < http://www.capetown.gov.za/en/stats/CityReports/Documents/Urban%20Renewal%20Programme/URP_Socio-Eco_Exec_Summary_228200612631_359.pdf>).

Richard Knight, 2001. *Housing in South Africa*. (Retrieved 23.8.2011, < <http://richardknight.homestead.com/files/sisahousing.htm>>).

Sytse de Maat, 2010. *To zone or not to zone*. (Retrieved 21.8.2011, < <http://theperfectslum.blogspot.com/2010/09/to-zone-or-not-to-zone.html>>).

South African Government Information, 2011. *Housing*. (Retrieved 15.9.2011, < <http://www.info.gov.za/aboutsa/housing.html>>).

Sun Academia, 2010. *Human Settlements: Formulations and Calibrations*. Amsterdam: Sun Academia.

Urban Renewal Project, 2005. *Khayelitsha-Mitchelles Plain Urban Renewal Programme: Profiles Of Khayelitsha And Mitchells Plain*. (Retrieved 19.11.2011, < <http://www.thedplg.gov.za/urp/Reports/Cabinet%20Lekgotla/Khayelitsha%20Mitchells%20Plainv2.pdf>>).

Yu, D. and Nieftagodien, S. , 2007. *Poverty and Migration: Evidence from the Khayelitsha/Mitchell's Plain Area*. SALDRU Working Paper No. 11.