

Moisture level in extruded diets for Atlantic salmon (*Salmo Salar*)-Effect on physical feed quality, growth performance and feed intake

YAFEI LI

NORWEGIAN UNIVERSITY OF LIFE SCIENCES
DEPARTMENT OF ANIMAL AND AQUACULTURAL SCIENCES
MASTER THESIS 30 CREDITS 2012



**Moisture level in extruded diets for Atlantic salmon
(*Salmo Salar*)-Effect on physical feed quality, growth
performance and feed intake**

Master Thesis in Feed Manufacturing Technology

(30 credits)

by

Yafei Li

Department of Animal and Aquacultural Sciences
Norwegian University of Life Sciences

Ås, Norway
September, 2012



Abstract

The aim of the study was to investigate the effect of moisture content on physical quality of extruded pellets such as hardness, DORIS value, water stability, bulk density, length and diameter. The experimental diets were also fed to Atlantic salmon in order to investigate effect of moisture of extruded pellets on weight gain, feed intake and feed utilization. A 91-day feeding experiment was carried out using fish with 968 g average initial weight, kept in seawater at 9.4 °C. Four experimental diets differing in water content were produced by adjusting drying time. The diets contained 2.5% (diet A), 5% (diet B), 7.5% (diet C) and 10% (diet D) of moisture. Diet C was soaked in salt water for 2 h before feeding and labelled diet E.

Significant differences among diets were found in hardness, DORIS value, water stability, bulk density, pellet length and diameter. Diet D with highest moisture level (10%) showed higher hardness, higher bulk density and less broken pellets compared to the other diets. Diet A with the lowest moisture level (2.5%) had significant lower water stability than the other diets after 60 min and 120 min in shaking water bath. After 240 min incubation in the shaking bath, diets D and E showed numerically higher water stability compared to the other three diets. High bulk density was associated with harder and less broken pellets. High hardness of pellets was associated with higher water stability. Atlantic salmon fed diets D and E had in average a non-significant but numerically higher weight gain, feed intake, specific growth rate, specific feeding rate, thermal growth coefficient compared to the other dietary treatments. A non-significant but numerically lower feed conversion ratio was observed fed fish with diet D compared to the other diets.

In conclusion, the present experiment showed that increasing moisture level in diets significantly improved physical quality of pellets, but had no effect on weight gain, feed intake or feed utilization. A numerical higher feed intake of the diets with highest moisture level indicated that elevated moisture level may have a potential to increase feed intake.

Keywords: *Extruded diets, Moisture, Physical quality, Feed intake.*

Contents

Abstract	II
Acknowledgement	IV
Abbreviations	V
1. Introduction	1
1.1 Production of fish feed-the feed manufacturing line	2
1.1.1 Receiving and storing of ingredients	2
1.1.2 Milling (particle size reduction).....	3
1.1.3 Batching and mixing	3
1.1.4 Extrusion production line.....	3
1.1.5 Drying	6
1.1.6 Cooling.....	6
1.1.7 Coating.....	7
1.2 Effects of extrusion processing on nutritional quality of the feed	7
1.3 Effects of ingredients and extrusion processing on physical quality of the feed	8
1.4 The interaction between physical and nutritional quality	10
1.5 Aim of study.....	11
2. Materials and methods	12
2.1 Diets	12
2.2 Fish trial	13
2.3 Chemical and physical quality analysis of the diet.....	13
2.4 Calculations and statistical analyses	15
3. Results.....	17
3.1 Composition of the diet.....	17
3.2 Physical quality of the pellet.....	17
3.3 Fish growth performance	19
3.4 Correlation among the physical quality and the fish growth performance parameters ...	19
4. Discussion	26
4.1 Effect of the moisture level on the physical quality of the pellets	26
4.2 Fish growth performance	28
4.3 Interaction between physical quality of experimental diets and fish growth performance	29
5. Conclusion	31
6. References.....	32

Acknowledgement

This study was funded by Centre for Research-based Innovation in Aquaculture Technology (CREATE). Analyzing of physical quality was carried out at feed lab at UMB. The fish trial was carried out at Nofima's research station in Sunndalsøra.

I would like to express my sincere gratitude to my dear supervisor Mette Sørensen, for her encouragement, patience and motivation. Thank you for trusting me, guiding me through scientific experiment planning, statistics analyzing, thesis writing, numerous discussion and also English grammar. Through your help, I expand the knowledge about fish feed production and fish nutrition. I want to congratulate her with a new pretty baby girl. She is not only a good professor, but also a great mother. I would also like to thank Maike Oehme for information and advices regarding the fish experiment.

Special thanks to Frank Sundby, who gave me many advices and helped me with the feed analyzing. I am also indebted to many researchers at Norfima, Sunndalsøra, who gave me a further knowledge about Salmon rearing system and sampling procedure.

Last but not least, I am grateful to my parents and friends, for their encouragement, understanding and support. I would like to give special gratitude to boyfriend, for all the support and love.

ÅS, September, 2012

Yafei Li

Abbreviations

DM = Dry matter

DV = DORIS value

FBW = Final body weight

FCR= Feed conversion ratio

FI = Feed intake

HDI = Holmen durability index

IBW = Initial body weight

RPM = Extruder screw speed

SFR = Specific feeding rate

SGR = Specific growth rate

SME= Specific mechanical energy

TGC = Thermal growth coefficient

WG = Weight gain

1. Introduction

Salmon farming has grown into a large industry in Norway. The farmed Atlantic salmon production has increased from 111,337 tons in 1989 to approximately 944,000 tons in 2010 (Fiskeridirektoratet, 2011). The quality of feed is important because the feed cost comprises more than 50% of the production cost of Atlantic salmon in Norway (FAO, 2009). High utilization of feed is hence important to reduce production cost and also to reduce emissions of nutrients to the water. According to Hardy (1989), a fish feed should meet the nutrient requirement of the fish and have a suitable size and texture that stimulate feed intake. Many studies have been carried out in order to evaluate the nutritional value of different ingredients and how they affect the nutrient digestibility, growth performance and feed intake of fish (Mundheim et al., 2004; Drew et al., 2007; Gatlin et al., 2007; Glencross et al., 2007). Some studies have also addressed the causes for variation in physical quality of feed (Sørensen, 2012), and the interaction between nutritional and physical quality (Baeverfjord et al., 2006; Glencross et al., 2010; Aas et al., 2011a). The physical quality of feed is affected by feed ingredients and processing conditions during production of fish feed (Sørensen et al., 2011a). Ideally the feed production process should improve nutrient digestibility, palatability, pellet durability, water stability and pellet shelf life (Barrows et al., 2007), and thereby improve the growth performance and feed efficiency of fish fed high quality feed.

The demand for aquafeeds worldwide was increasing at an average rate of 10.9 percent per year since 1995 to meet the requirement of aquaculture (FAO, 2011). The extrusion processing technology was introduced to the Norwegian fish feed industry in 1980's and has become the predominant process in the manufacturing of fish feed. In 2010, about 1.34 million tons of feed consumed in Norwegian fish farming were extruded (Sørensen et al., 2011b).

Extrusion is defined as “the process by which moistened, expansible, starchy, and/or proteinaceous materials are plasticized in a tube by a combination of moisture, pressure, heat, and mechanical shear” (Smith, 1976). Feed pellets are shaped when the dough is forced through a specifically designed die opening. During the extrusion process, high temperature (120-130 °C) and high pressure (20-30 bar) are used to melt particles and knead the ingredients into a dough.

The residence time of the feed at elevated temperature is short (5-10 sec). The nutritional value of the feed is thus not negatively affected (Sørensen, 2003; Sørensen et al., 2005; Barrows et al., 2007). The heat and high moisture level facilitate gelatinization of starch and denaturation of proteins, thus enhance the nutritional and physical quality of the feed. Extrusion can be used to improve nutritional value of a fish diet. Barrows et al. (2007) showed that high temperature (127 °C) and short time in the extruder barrel gave greater weight gain of rainbow trout compared to low temperature (93 °C). Extruded feeds are porous, and have a great potential to absorb fat (up to 400 g oil per kg feed) post extrusion, in order to produce high-energy feeds (Sørensen, 2003; Sørensen et al., 2011a).

1.1 Production of fish feed-the feed manufacturing line

The manufacturing line includes the following components: receiving and storing of main ingredients, milling, batching, mixing, extruding, drying, cooling, vacuum coating and packaging. The processing below is based on Schofield (2005).

1.1.1 Receiving and storing of ingredients

Receiving the ingredients is the first step of the manufacturing line, which includes receiving and placement of ingredients, weight verification, initial inspection, sampling, and quality control of each ingredient. Before unloading, the quality of feed ingredients need to be analyzed in order to ensure that they all meet the required specification. The ingredients (dry ingredients and liquids) are received in either bulk trucks or railcars. Special attention must be paid to the dust control at unloading area because here is the largest dust emission area in a feed plant.

The ingredients are stored by different means at a feed plant depending on its usage, quality and price. However, all of them are based on “first-in, first-out” principle. Dry ingredients are usually stored in silos with live-bottoms, vibrating or other agitating to avoid bridging. Liquids such as amino acids or molasses are usually stored in specific tanks with pumps according to the manufacturing’s recommendation to keep freshness. To prevent oxidation of fats and oils, ingredients may need heating or supplementation of antioxidants. Microingredients are the materials added in small quantities (mg, ug), such as vitamins, elements and astaxanthin. They

are usually stored in special bags or containers. The size of feed mill storage depends on the percentage of each ingredient used in formulation and the amount used every day. During storage, moisture level needs to be strictly controlled to avoid destruction by mould, bacteria or insects. A good storing management is required to ensure that the ingredients are in normal condition before they are used in the production.

1.1.2 Milling (particle size reduction)

Milling or grinding is used as a mean to reduce the particle size of ingredients. Compression and impact are the main principles for reduction of particle size. Fine milling increases the surface area of particles, resulting in improved digestion, binding between particles and increased particle homogeneity. Moreover, milling eliminates germination ability of seeds. The increased surface area also improves water absorption and distribution of water in the particles. Water is important for starch gelatinization and protein denaturation. The milling also result in contribute improved physical and nutritional quality.

1.1.3 Batching and mixing

Batching and mixing is carried out to ensure that all the ingredients are added in the right amount defined by the specific formula. Ideally, each pellet or mouthful should contain the accurate amount of nutrients. Continuous or batch mixing systems are used. The continuous system is batching ingredients continuously into the mixer. Ingredients are weighed individually on a scale and added directly in to the mixer. Optimal mixing time is depending on mixer type, usually 2-4 minutes in modern feed industry. During the mixing cycle, macro and micro ingredients are homogenously mixed. The mixed batch of ingredients are then transferred to a supply bin installed in front of the extruder serving a temporarily storage to ensure a homogeneous mash flow through the extruder.

1.1.4 Extrusion production line

The extrusion line includes: a supply bin, delivery system, pre-conditioner, extruder barrel and die (Figure 1).

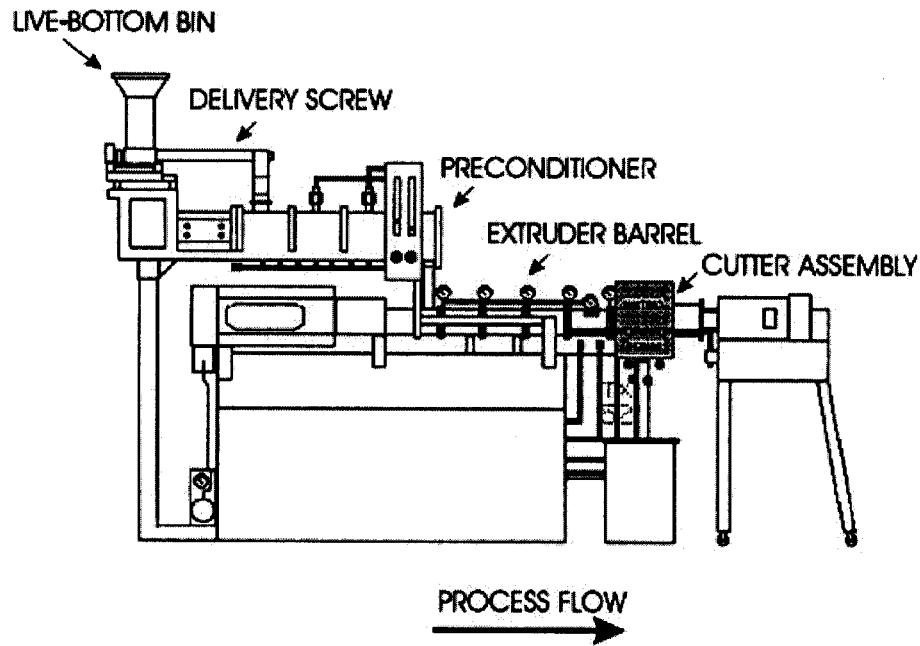

Figure 1. Common components on the extruder line (Brent, 1999).

The feed delivery system is conveying the mixed feed ingredients from the holding bin into the pre-conditioner. Ingredients can be metered by either volumetric or gravimetric systems. The specialized metering device controls the production capacity and provides a uniform flow. The gravimetric feeder has a more complex design and is more expensive compared to volumetric feeder. Use of gravimetric feeding system allows operational control, and feeding rate can be changed with bulk density of ingredients. The production capacity can be changed by adjusting the velocity (rpm) of the feeder.

The metered dry and liquid ingredients are added separately into the pre-conditioner where they are mixed, heated and moisturized by contact with hot water or steam. The pre-conditioner usually consists of one or two chambers (atmospheric or pressurized) with one or two mixing/conveying elements and one or two rotating shafts. The normal retention time is ranging from 60 to 300 sec, and the temperature from 80 to 95 °C during this process (Strahm, 2000; Beyer, 2007). During pre-conditioning, the feed mash is mixed with water and steam. During the process, particles are softened, starch start to gelatinize and protein begin to denature. A good cooking is achieved with optimal moisture level, proper retention time and temperature. Other

advantages of pre-conditioning are reduced mechanical power consumption and wear of extruder barrel, as well as improved capacity of the extruder and enhanced texture of the final products.

The extruder barrel consists of one or two screws and barrel segments. It is the heart of the process where the main transformation of ingredients is taking place, defining the final feed characteristics. Depending on the number of screw in the barrel, extruders are generally classified into single-screw and twin-screw extruders. Compared to the single-screw extruders, twin-screw extruders are normally designed to add a higher moisture content and higher thermal energy during the operating process. Moreover, twin-screw extruders allow greater flexibility in ingredients selection.

The extruder screws are made up by different elements and can differ in configuration. Shear locks are used to interrupt the mash flow and influence mixing. The screw configurations of the extruders barrel generally include three major processing zones: feeding, kneading and final cooking (Figure 2). In the feeding zone, feed mash with low density is entering the inlet of the extruder barrel, and distributed into extruder processing chamber. Water may be added into the barrel in this zone aiming to improve viscosity and texture of feed mash and enhance heat transfer. In the kneading zone, pressure starts to develop as the degree of screw fill increases. Steam may be added in this zone to increase the thermal energy input. Moderate shear is achieved in the kneading zone, temperature start to increase and a dough-like mash appears. As the mash is conveyed to the cooking zone, the temperature and pressure is increasing rapidly. The shear rate is highest in this area before feed mash is forced through the die(s) to get the final shape. The pressure in front of the die can vary between 20-40 bar.

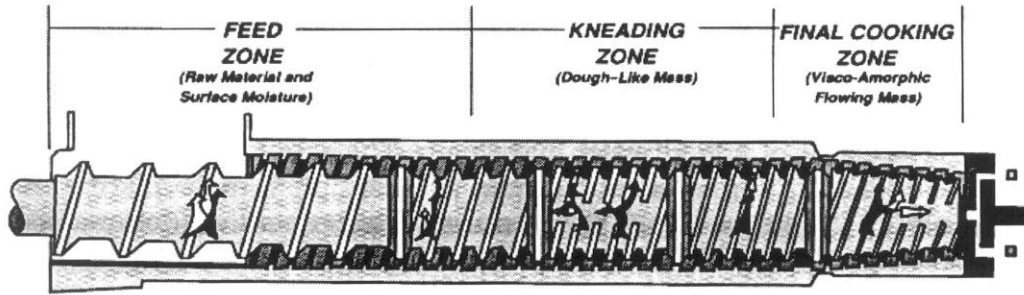

Figure 2. The figure is showing three principal different regions on the screw (Rokey, 2000).

The extrusion die is mounted at the discharge of extruder. The die(s) make restriction to the flow of mash, resulting in pressure build up. Numbers of extruder die vary with die hole diameter and die thickness. The pressure of die, temperature and capacity in the extruder are affected by die configuration. Consequently, the physical characteristics of final products such as sinking velocity, bulk density, fat absorption and fat holding capacity are influenced by the open orifice. The speed of the knife and the number of blades in the knife are determining the length of pellets. When pellets are forced out of the extruder, steam flash off resulting in pellets expansion.

1.1.5 Drying

High moisture level facilitates growth of fungus and bacteria in feed. The main purpose of drying is to reduce feed moisture to a level where mould and bacteria do not grow. Normally, feed is dried to a moisture level below 10% to achieve satisfactory shelf life. In principle, horizontal and vertical types of driers can be used on extruded pellets. The two designs use air to remove moisture. The main difference is that horizontal dryer has a cross flowing air pattern with air flowing either up or down through the product bed. The vertical dryer is using counter flow principle, with air flowing from bottom to top of the dryer and pellets dropping from the top to the bottom. The feed release water until moisture level has reached the target level. The air temperature can range from 100 to 200 °C. The drying efficiency is affected by air moisture and targeted moisture level in the final extruded feed.

1.1.6 Cooling

After drying, the moisture in feed will be stable and temperature can be high (above 80 °C).

Cooling process aims to reduce feed temperature. Feed needs to be cooled to ambient temperature in order to prevent condensation inside the bag.

1.1.7 Coating

High energy feeds may have up to 40% fat (Sørensen, 2012). Most of the fat has to be added post extrusion, usually by vacuum coating. The working principle of this process is to create vacuum inside the pellets. The pellets are then sprayed with oil. As the vacuum is released, the oil will be sucked into the pellets. In order to absorb oil, the pellets need to have a porous structure. Also the moisture level should be lower than 8%. Too much moisture in the pellet may reduce fat absorption.

1.2 Effects of extrusion processing on nutritional quality of the feed

Modern nutrient-dense diet for fish is a mixture of ingredients optimized to meet the nutritional requirements. Nutritional quality of the feed is usually defined by chemical composition and the ability of the target animal to utilize the dietary nutrients for growth (Morken, 2011). Depending on species and age the salmonid feed contain: 40-60% protein, 20-40% fat, 10-20% carbohydrates, 5-12% moisture, vitamins and minerals. Extrusion processing may change chemical and nutritional quality of diets (Singh et al., 2007), and consequently improve or reduce feed utilization, depending on the processing conditions such as temperature, moisture, shear and retention time applied during processing.

Extrusion process causes chemical and physicochemical reactions in raw materials (Camire, 2001). During the process, physicochemical reaction usually occur at an early stage, while chemical reaction take place at a later of stage (Camire, 2000). The moderate heat treatment (temperatures < 150 °C) facilitate gelatinization of starch and hydration of proteins, leaving starch and protein more susceptible to digestive enzymes, improving nutritional quality of diet (Guy, 2001; Barrows et al., 2007; Morken et al., 2011). When the feed mash is passing through the die, the release of steam and pressure cause expansion and gelatinization of starch as well as protein denaturation (Shankar and Bandyopadhyay, 2005). Gelatinized starch increase the viscosity of the dough (Lundblad et al., 2011), and is important for binding and expansion of

pellets. Utilization of starch in carnivorous species is also improved by gelatinization (Kroghdahl et al., 2005). However, starch should be added to a minimum to the salmonids diets because carnivorous fish have limited ability to digest starch (Sargent et al., 2002). Heat used in the process is also denaturing protein, reducing the level of thermolabile anti-nutrients present in plant material, resulting in improved protein digestibility in fish (Francis et al., 2001; Ibrahim et al., 2002; Denstadli et al., 2006).

Excessive heating especially in combination with low moisture level, may reduce protein digestibility by destroying the primary structure of protein and inducing indigestible bonds among individual amino acids, such as disulphide bonds and cross linked amino acids (Opstvedt et al., 1984; Chen et al., 2011). The protein quality can also be reduced by Maillard reaction between an amino acids (especially lysine) and a reducing sugar.

Different ingredients have unique processing characteristics, thus, in order to obtain acceptable nutritional quality, extrusion conditions need to be adjusted according to the different ingredients and target animal (Romarheim, 2007; Sørensen, 2011a).

1.3 Effects of ingredients and extrusion processing on physical quality of the feed

The physical quality of feed is defined as the ability of feed to withstand handling and transportation without forming excessive amount of dust as well as fine particles. Variation in physical quality are observed among commercial diets because a range of ingredients are used in aquatic feed (Houlihan et al., 2001; Refstie et al., 2006; Sørensen et al., 2009). Feed processing parameters and extruder configuration used in fish feed production also affect physical quality of extruded fish feed (Sørensen et al., 2009, 2010, 2011).

Physical characteristics of extruded fish feed are usually defined by properties such as durability, hardness, water stability, bulk density, oil absorption, oil leakage, expansion ratio and sinking velocity. These properties were previously tested with different methods. For example, durability of pellets can be tested using the DORIS tester, Holmen tester, Lignotest and other test devices (Askeland et al., 2002; Aas et al., 2011b; Sørensen, 2011a). These tests aim to evaluate the

capability of the pellets to withstand stress from pneumatic or mechanical conveying without generating excessive amount of fractures and fines (Sørensen, 2012). DORIS tester is a new device developed for high-energy extruded feed (Aas et al., 2011b). Holmen- and Ligno-test are most often reported for uncoated feed because of problems with oil leaking when high-energy extruded feed are tested (Sørensen, 2012). Sørensen et al. (2011a) reported that DORIS value (DV) showed a significant negative correlation with Holmen durability (HDI). Thus DV can be used to instead of HDI. Hardness determines the maximum force needed to crush pellets (Thomas and van der Poel, 1996). “Texture- Analyzer” and other test devices, e.g. Kahl device are often used to measure hardness.

Modern fish feed is multisource-based, and today plant ingredients are to a large extent replacing fish meal and oil. Compared to fish meal, plant sources with a low degree of processing are inexpensive. Moreover, some studies have reported that use of plant ingredients may improve physical quality of extruded feed (Sørensen et al., 2009; 2010; 2011a; Øverland et al., 2009; Kraugerud et al., 2011; Morken et al., 2011). Functional properties of plant ingredients seem to improve bonding between particles (Svihus et al., 2005). The functional properties of starch vary among starch sources and is associated with structure of starch granules, amylose : amylopectin ratio and chemical composition (Svihus et al., 2005). Starch gelatinization is affected by temperature and free water in the feed production system (Sørensen, 2012). Sørensen et al. (2009) showed that physical quality of feed such as bulk density, durability and hardness was improved when soybean meal (toasted or untoasted) was included in extruded feeds. Sørensen et al. (2010) showed that pea and wheat starch had different viscosity resulting in different physical quality of extruded feeds. However, Kraugerud et al. (2011) observed that diets containing protein-rich sunflower and rapeseed gave more durable and harder pellets than diets containing starch-rich legumes. These findings suggest that starch is an important, but not unique binder in extruded feed.

Water added either as steam or liquid is an important plasticizer during extrusion. Besides, moisture itself is a binder and is activating other binders such as starch, proteins, soluble carbohydrates when combined with high temperatures (Lundblad et al., 2009). Earlier studies have shown that moisture is a process variable significantly affecting final product properties

(Chevanan et al., 2007, 2008; Draganovic et al., 2011). Draganovic et al. (2011) reported that feed moisture was the main factor determining bulk density and oil absorption capacity. Water absorption capacity of ingredients is affected by chemical composition and physical state of water, as well as particle size distribution of ingredients (Draganovic et al., 2011). Small particles in the feed mash are more easily softened and hydrated than big particles, hence reducing particle size improves physical quality of pellets.

Physical quality of pellets is also affected by extruder configuration and processing parameters (Thomas et al., 1997). Extruder parameters can be adjusted according to the materials used when producing extruded feed (Sørensen et al., 2010). The process can therefore be optimized to utilize functional properties of ingredients in order to improve physical quality of feed.

Screw configuration is affecting the cooking of starch and protein by changing residence time and energy input to the dough (Gogoi et al., 1996). Increasing the specific mechanical energy (SME) and temperature during extrusion processing increase starch gelatinization (Cai and Diosady, 1993; Gropper et al., 2002), improving durability and hardness of pellets (Cai and Diosady, 1993; Yoshitomi, 2004). Sørensen et al. (2010) showed that different screw configurations generated their own unique SME and screw configuration significantly affected physical quality such as HDI and hardness of pellets when different starch sources were used. Changing screw speed (RPM) affected SME (Sørensen et al., 2011a). Increasing screw speed from 220 to 300 RPM gave a greater expansion ratio and improved HDI and oil absorption of pellets. Some studies also indicated that SME was affected by ingredients (Kraugerud, 2008; Øverland et al., 2009; Sørensen et al., 2009; Kraugerud et al., 2011). For example, Sørensen et al. (2009) reported that diets containing fish meal, toasted soybean meal (SBM) white flakes generated different SME when extruded with a standardized screw configuration, resulting in different physical quality of pellets.

1.4 The interaction between physical and nutritional quality

A few previous studies have shown the interaction between physical and nutritional quality. One of the earliest studies was carried out by Hilton et al. (1981). This study reported that the extruded

feed was more durable, had better water stability and higher water absorption. The extruded diets, however, gave prolonged gastric emptying rate and reduced feed intake in rainbow trout compared to steam pelleted diets. In line with the latter experiment, Venou et al. (2009) showed similar results with gilthead sea bream. Extruded feed reduced feed intake, feed utilization and gave prolonged gastric retention time. Aas et al. (2011a) showed that feed with high water stability had the highest pellet hardness, lower dust formation and broken pellets concurrent with lower feed intake in rainbow trout. Diets with low water stability gave accumulation of free oil in the stomach that may lead to oil-belching (Baeverfjord et al., 2006; Aas et al., 2011a). Other physical quality, e.g. hardness may also affect nutritional quality. Glencross et al. (2011) reported higher feed intake in rainbow trout fed diets with increasing level of lupin that resulted in higher hardness. Published literature have reported longer gastric retention time and reduced feed intake with higher water stability of pellets. However hardness may have less or no effect on feed intake in salmonids. Nevertheless, these studies suggest that there may be a correlation between physical and nutritional quality of feed.

1.5 Aim of study

Interaction between physical quality of extruded and nutritional response is poorly understood. No studies have previously reported the effect of varying moisture content on physical quality of extruded high energy feed and the nutritional response when fish are fed with these diets. The aim of the present study was, therefore, to investigate the effect of moisture content of extruded diets on physical quality of pellets, feed intake, feed conversion and growth of Atlantic salmon.

2. Materials and methods

2.1 Diets

Four extruded commercial fish diets differing in water content (2.5%, 5%, 7.5% and 10%) denoted diet A, B, C and D were produced at BioMar pilot plant Tech Centre in Brande, Denmark. Different water content was achieved by drying intensity. Diet C was soaked in 35% salt water for 2 h to dry matter (DM) of 90.6% and labelled diet E. The soaking procedure was developed by researchers at Sunndalsøra. The soaking of pellets was carried out before analysis of physical quality. Pellets from diet C was placed into a beaker. Seawater was poured into the beaker until all the pellets were covered. The pellets were soaked for 2 h and were kept in a cooler (4 °C) during the soaking. After the soaking, seawater was drained off the pellets. I used the same procedure, and soaking of pellets was carried out with seawater from Sunndalsøra. Analysis of physical quality was carried out immediately after the soaking procedure.

Physical quality of pellets were tested on all five diets, that had the same ingredient composition, but differing in moisture content. The diets were stored in a cooler at 4 °C until use. The experimental diets were produced two times, and diet from the second production was used in the feeding experiment. Diet from the first feed production was labelled (A₁, B₁, C₁, D₁, diet D₁ was soaked and labelled E₁). The diets from the first feed production were intended for a feeding experiment with Atlantic salmon. The feeding experiment was however terminated because the feed intake (FI) never came up to the expected level with these diets. It was therefore decided to produce new diets. In order to compare diets from the two productions, physical quality of all diets were analyzed.

The formulation of the diets and feed processing parameters is proprietary of the feed producer, but were standardized for both feed production. All diets were dried in a 6 layer colum drier. In order to achieve targeted moisture content of diet, different retention time were used for the diets (Table 1).

Table 1. Temperature and cycletime for drying of diet A, B, C and D

	Diet A	Diet B	Diet C	Diet D
Temperature (°C)	117	118	117	118
Cycletime (min)	350	230	115	50

2.2 Fish trial

A total of 240 Atlantic salmon at average initial weight of 968 g were used in a growth experiment carried out at Norfima, Sunndalsøra, Norway. The fish, 16 fish per tank (size: 1 × 1 m², water depth 36 cm) were kept in 25-27 l/min flow of seawater with an average temperature of 9.4 °C. The oxygen saturation of water changed between 92-102% during experiment and the salinity was 35‰. The fish was exposed to 24 h⁻¹ artificial light per day. Each diet was fed to triplicate tanks of fish for 91 days.

The fish were fed one meal per day lasted for about 30 min, using electrically driven belt feeders. The amount of diet was adjusted every day based on the FI for the last three days aiming at 20% over feeding. The daily FI was calculated according to Helland et al. (1996). The uneaten diet was collected from the outlet water of each tank with wiremesh screens.

At the termination of the experiment, 16 fish each tank (48 fish per diets) were weighted and inspected for sex maturation. The fish were anesthetized before weighting.

2.3 Chemical and physical quality analysis of the diet

The chemical composition of the diets was analyzed by Nofima, Sunndalsøra, Norway (Table 2). I analyzed DM by crushing pellets in a porcelain mortar prior to drying in the heating cabinet at 104 °C for 18 h.

Table 2. Chemical composition of the diets

	Diet A	Diet B	Diet C	Diet D	Diet E (Soaked diet C)
Dry matter (DM, g kg ⁻¹)	956	933	917	903	906
In dry matter:					
Crude protein ¹ (g kg ⁻¹)	375	367	371	369	372
Crude lipid (g kg ⁻¹)	347	350	351	349	355
Starch (g kg ⁻¹)	57.7	54.9	57.0	57.0	55.8
Energy (MJ kg ⁻¹)	26.3	26.1	26.0	26.3	26.2
Minerals:					
Yttriumoxid (g kg ⁻¹)	0.47	0.46	0.45	0.47	0.45
Phosphorous (g kg ⁻¹)	10.7	10.7	10.7	10.7	10.4
Calcium (g kg ⁻¹)	9.6	9.7	9.9	9.5	9.7
Magnesium (g kg ⁻¹)	2.1	2.1	2.1	2.1	2.5
Sodium (g kg ⁻¹)	3.1	3.0	3.2	3.1	5.8
Iron (mg kg ⁻¹)	210	212	212	205	259
Manganese (mg kg ⁻¹)	32.2	33.6	33.9	31.8	31.5
Zinc (mg kg ⁻¹)	178	169	169	168	165
Copper (mg kg ⁻¹)	10.2	10.0	10.1	10.5	9.6

¹N × 6.25

Physical quality of the diets was evaluated by measuring hardness, length and diameter, bulk density, DORIS durability and water stability.

Hardness or strength at rupture, and diameter of pellets was measured using a Texture-Analyser (TA-XT2[®], Model 1000R; SMS Stable Micro Systems, Blackdown Rural Industries, Surrey, UK). The length of pellets was manually measured by use of an electronical digital caliper. This procedure was carried out as described by Aas et al. (2011b).

The bulk density of the pellet was analyzed by loosely filling up a 1 liter cylinder with pellets, as

described by Aas et al. (2011b). The pile of pellets exceeding the edge of cylinder was removed by scraping a ruler one time over the top. The cylinder with pellets was then weighted on a balance. Triplicate measurements were carried out and bulk density (g L^{-1}) of each replicated was calculated as mass of the sample (g) to the unit volume of the sample (L).

DORIS durability was measured in a DORIS tester (AKVAsmart Bryne, Norway). Pellet (350 g) samples were run through the DORIS tester. The samples were then sieved in a sieving machine (Retsch GmbH, Haan, Germany) with three sieves (mesh size 8 mm, 5.6 mm and 2.36 mm) and a collector, at 1.5 amplitudes for 30 sec. Each fracture remaining on the sieves and on the bottom collector was weighted. Every sample was tested in triplicates. The pellets collected on the 8 mm screen were considered as whole pellets, the fracture collected on the 5.6 mm screen were reported as large fracture, the fracture collected on the 2.36 mm were reported as small fracture, and the dust (< 2.36 mm) on the bottom collector was reported as fines. The sum of the percentage of fines and fracture (2.36-8 mm) is reported DORIS value (DV).

Water stability was tested in a shaking water bath (Julabo laborotechnik GmbH, Seelbath, Germany) (software version: SW22 n2.6). This procedure was carried out according to Baeverfjord et al. (2006). A sample of 20 g pellets was placed into circular wire netting baskets with 3 mm mesh size and a diameter of 8 cm. The baskets with pellets were then placed into beakers (600 ml) and 300 ml distilled water was added. Six beakers were placed into the water bath in each testing cycle. Three replicates per diet were incubated in the water bath at 25 °C, 110 rpm shaking frequency for 60 min, 120 min and 240 min, respectively. When the shaking process was completed, the baskets were gently taken from water bath and weighted, then placed into the heating cabinet at 104 °C for 18 h. The baskets were weighted again after drying process. Water stability (%) was calculated as the DM (%) remained in the basket after incubation divided by DM (%) before incubation.

2.4 Calculations and statistical analyses

Fish growth performance were calculated using the following equations:

Weight gain (WG) = Initial body weight (IBW, g) – Final body weight (FBW, g)

Feed intake (FI) = Cumulative feed intake (g, dry weight) / Fish number

Feed conversion ratio (FCR) = Feed intake (g, dry weight) / Weight gain (g, wet weight)

Specific growth rate (SGR) = $100 \times [\ln \text{ final body weight (g)} - \ln \text{ initial body weight (g)}] / \text{Days fed}$

Specific feeding rate (SFR) = Specific growth rate \times Feed conversion ratio

Thermal growth coefficient (TGC) = $1000 \times [\text{final body weight (g)}^{1/3} - \text{initial body weight (g)}^{1/3}] / \text{Sum daydegrees}$

The physical quality and fish trial data were analysed by using the SAS system 9.2 for Windows (SAS Institute Inc., Cary, NC, USA). The fish trial was run with triplicate tanks, each tank was the experimental unit. The dependent variables bulk density, DORIS durability, hardness, diameter, water stability, IBW, FBW, WG, FI, FCR, SGR, SFR and TGC were tested by using one-way analysis of variance (ANOVA). The results were presented as mean \pm S.E.M. (standard error means) for each diet. Significant differences among means were shown as $P \leq 0.05$, P values between 0.05 and 0.1 were referred to as trends, while P values large than 0.1 were regarded as non-significant difference. The correlation analyses were determined using the Pearson correlation coefficients procedure.

3. Results

3.1 Composition of the diet

The chemical composition of the experimental diets is shown in Table 2. The DM of diets was decreased with increasing moisture level in diets. Analysis of the DM of diet E (soaked diet) was 90.6%. Our DM analysis was higher than when the soaking procedure was established at Sunndalsøra. The researchers at Sunndalsøra obtained a DM content of 73.2% after two hours soaking. Magnesium, Sodium and Iron content were higher in diet E compared to diet C.

3.2 Physical quality of the pellet

The physical quality of extruded diets (A, B, C, D and E) with different moisture content is shown in Table 3. Significant differences among diets were found in pellet length, diameter, bulk density and hardness. Diet A was significantly longer than diets B, C and D, and diet C was significantly longer than diets B and D, while diet B was longer than diet D. Diet E had the significantly largest diameter, while diets A, C and D had the smallest diameter. The bulk density was associated with moisture content and significantly increased with higher moisture content in the diets. Diet D had the largest bulk density followed by diets C, B and A. Diets C and D had the highest hardness, while diet A had the lowest hardness. No significant differences in hardness were observed between diets B and E.

The DV varied significantly among the diets. Diet A generated highest amount of large fracture (5.6-8 mm), small fracture (2.36-5.6 mm) and fines (< 2.36 mm) and therefore had the highest DV, followed by diets B, C and D, respectively. On the contrary, diet D had the highest amount of intact pellets (> 8 mm), and the lowest amount of dust, followed by diets C, B and A.

The water stability was significantly lowest for diet A, while no differences were observed among diets B, C, D and E, after 60 min and 120 min in shaking water bath. After 240 min incubation in the shaking water bath, diets E and D were numerical higher in water stability compared to the other diets, but no significant difference were noted.

The physical quality of diets A₁, B₁, C₁, D₁ and E₁ is given in Table 4. Length and diameter were significantly different among the diets. Diet A₁ had the significantly shortest length compared to the other diets. Diet E₁ had a significantly larger diameter than the other diets. No significant differences were observed in diameter between diets B₁ and C₁, but these two diets had significantly larger diameter than diet D₁ and A₁. Diet A₁ had the significantly smallest diameter. The bulk density significantly differed among the diets. Diet A₁ was the heaviest followed by diets D₁, C₁ and B₁. Hardness of the pellets also significantly differed among the diets. Diets C₁ and D₁ had the highest hardness, while diet E₁ had the lowest hardness. No significant differences in hardness were found between diets A₁ and B₁.

DV significantly differed among the diets A₁, B₁, C₁ and D₁. Diet C₁ had the highest DV because it generated the highest amount of large fracture (5.6-8 mm) and small fracture (2.36-5.6 mm). Diet B₁ generated highest amount of fines (< 2.36 mm), and had a higher DV than diets A₁ and D₁. Diets A₁ and D₁ generated the highest amount of intact pellets (> 8 mm), and had the lowest DV.

The water stability differed significantly among diets A₁, B₁, C₁, D₁ and E₁. Diet C₁ was more water stable than the other four diets after 60 min and 120 min in shaking water bath, but after 240 min incubation it tended to be less stable than diet B₁. Diet B₁ was the most water stable diet at 240 min incubation. Diet A₁ had the significantly lowest water stability after 60 min, 120 min and 240 min water bath.

There were some differences between two feed productions in physical quality. Diets A₁, B₁, C₁, D₁ had an average heavier pellets (663.35 g), compared to diets A, B, C, D (656.26 g). Hardness of pellets in the first feed production was slightly higher with an average of 46.05 N compared to an average of 37.89 N in the second production. DV was lower for pellets from the first production with an average 12.65%, compared to the second production with an average of 23.71%. Water stability of pellets from the first and second productions showed almost the same values at 60 min and 120 min, while the stability was one percentage point higher at 240 min for pellets from the first production.

A correlation analysis (Table 5) showed that bulk density of pellets was positively correlated

with hardness ($P = 0.009$), and negatively correlated with DV ($P < 0.001$). Hardness was positively correlated with water stability at 60 min ($P = 0.005$) and 240 min ($P = 0.009$).

3.3 Fish growth performance

Growth performance of the fish is given in Table 6. The fish grew from average start weight of 967.92 g to an average final weight of 1872.21 g, giving an average increase in body weight of 93.43%. No significant differences were observed in IBW, FBW, WG, FI, FCR, SGR, SFR and TGC among fish fed the experimental diets. The FI per fish was ranging from 649.71 g to 832.34 g among the diets. Diets D and E had a numerically higher WG, FI, SGR, SFR and TGC compared to the other diets, though no significant differences were noted. Diet D had the numerically lowest FCR was observed among the diets. The mortality was low, only one fish died during the experimental period.

Correlation among salmon growth performance parameters and feed utilization data are shown in Table 7. FBW was negatively correlated with IBW ($P < 0.001$), WG ($P < 0.001$), FI ($P < 0.001$), SGR ($P < 0.001$), SFR ($P < 0.001$) and TGC ($P < 0.001$). IBW was positively correlated with SGR ($P = 0.026$), SFR ($P = 0.014$) and TGC ($P = 0.007$). IBW was negatively correlated with WG ($P = 0.001$) and FI ($P = 0.001$). WG was negatively correlated with FI ($P < 0.001$), SGR ($P < 0.001$), SFR ($P < 0.001$) and TGC ($P < 0.001$). FI was negatively correlated with SGR ($P < 0.001$), SFR ($P < 0.001$) and TGC ($P < 0.001$). SGR was negatively correlated with SFR ($P < 0.001$) and TGC ($P < 0.001$). SFR was negatively correlatively with TGC ($P < 0.001$).

3.4 Correlation among the physical quality and the fish growth performance parameters

The correlation coefficients obtained between physical quality and fish growth performance parameters are presented in Table 8. Physical quality parameters such as bulk density, hardness, DORIS durability and water stability were highly correlated. The data also showed fish growth performance parameters like WG, FI, SGR, SFR and TGC were well correlated. However, physical quality and fish growth performance parameters were not well correlated. SGR of fish and DORIS durability of diets was the least correlated of the relationships noted ($P = 0.998$).

Table 3. Physical quality of five extruded diets (labelled A, B, C, D and E) measured as length, diameter, hardness, bulk density, DORIS durability and water stability, respectively. For length, diameter and hardness n = 30, the remaining variables n = 3. Data are presented as mean \pm S.E.M.

	Diet A	Diet B	Diet C	Diet D	Diet E (soaked diet C)	ANOVA P<F
Length (mm)	9.97 \pm 0.06 ^a	9.26 \pm 0.07 ^{bc}	9.39 \pm 0.13 ^b	9.11 \pm 0.10 ^c		<0.0001
Diameter (mm)	10.53 \pm 0.06 ^c	10.98 \pm 0.12 ^b	10.55 \pm 0.04 ^c	10.64 \pm 0.04 ^c	11.38 \pm 0.03 ^a	<0.0001
Bulk density (g L ⁻¹)	618.06 \pm 0.46 ^d	655.28 \pm 0.46 ^c	673.26 \pm 0.26 ^b	678.41 \pm 0.06 ^a		<0.0001
Hardness (N)	30.03 \pm 0.95 ^c	37.16 \pm 1.43 ^b	44.64 \pm 1.58 ^a	43.22 \pm 1.30 ^a	34.41 \pm 0.85 ^b	<0.0001
DORIS test						
DORIS value (%)	61.29 \pm 0.63 ^a	26.22 \pm 0.29 ^b	6.09 \pm 0.39 ^c	1.25 \pm 0.06 ^d		<0.0001
Intact pellets (> 8 mm) (%)	37.90 \pm 0.92 ^d	73.63 \pm 0.30 ^c	93.87 \pm 0.38 ^b	98.83 \pm 0.09 ^a		<0.0001
Large fracture (5.6-8 mm) (%)	30.43 \pm 0.43 ^a	12.93 \pm 0.55 ^b	2.60 \pm 0.23 ^c	0.40 \pm 0.06 ^d		<0.0001
Small fracture (2.36-5.6 mm) (%)	19.00 \pm 0.84 ^a	7.10 \pm 0.30 ^b	1.90 \pm 0.06 ^c	0.50 \pm 0.00 ^d		<0.0001
Fines (< 2.36 mm) (%)	11.87 \pm 0.15 ^a	6.17 \pm 0.32 ^b	1.57 \pm 0.09 ^c	0.37 \pm 0.03 ^d		<0.0001
Water stability (%)						
60 min (%)	95.72 \pm 0.28 ^b	96.63 \pm 0.10 ^a	96.58 \pm 0.19 ^a	96.88 \pm 0.02 ^a	96.47 \pm 0.09 ^a	0.0054
120 min (%)	93.86 \pm 0.16 ^b	94.83 \pm 0.18 ^a	94.78 \pm 0.36 ^a	95.61 \pm 0.09 ^a	95.35 \pm 0.37 ^a	0.0071
240 min (%)	92.76 \pm 0.22	93.10 \pm 0.19	92.45 \pm 0.50	93.61 \pm 0.17	93.66 \pm 0.25	0.0593

^{a, b, c, d} Indicate significant differences ($p \leq 0.05$) among diets.

Table 4. Physical quality of five extruded diets (labelled A₁, B₁, C₁, D₁ and E₁) measured as length, diameter, hardness, bulk density, DORIS durability and water stability, respectively. For length, diameter and hardness n = 30 and for the other variables n = 3. Data are showed as mean ± S.E.M.

	Diet A ₁	Diet B ₁	Diet C ₁	Diet D ₁	Diet E ₁ (soaked diet D ₁)	ANOVA P<F
Length (mm)	8.89 ± 0.08 ^b	9.43 ± 0.10 ^a	9.31 ± 0.07 ^a	9.31 ± 0.06 ^a		<0.0001
Diameter (mm)	10.26 ± 0.06 ^c	10.52 ± 0.06 ^b	10.63 ± 0.12 ^b	10.43 ± 0.04 ^{bc}	11.14 ± 0.04 ^a	<0.0001
Bulk density (g L ⁻¹)	680.28 ± 0.32 ^a	651.26 ± 0.18 ^d	656.69 ± 0.11 ^c	665.18 ± 0.27 ^b		<0.0001
Hardness (N)	41.77 ± 2.44 ^b	44.67 ± 2.43 ^b	53.27 ± 1.65 ^a	54.72 ± 1.13 ^a	35.69 ± 0.85 ^c	<0.0001
DORIS test						
DORIS value (%)	2.51 ± 0.26 ^c	19.96 ± 0.39 ^b	25.76 ± 0.56 ^a	2.35 ± 0.22 ^c		<0.0001
Intact pellets (> 8 mm) (%)	97.37 ± 0.24 ^a	79.77 ± 0.41 ^b	73.87 ± 0.54 ^c	97.67 ± 0.20 ^a		<0.0001
Large fracture (5.6-8 mm) (%)	1.17 ± 0.18 ^c	11.07 ± 0.38 ^b	15.30 ± 0.45 ^a	0.90 ± 0.12 ^c		<0.0001
Small fracture (2.36-5.6 mm) (%)	0.53 ± 0.07 ^c	4.60 ± 0.10 ^b	6.80 ± 0.20 ^a	0.73 ± 0.12 ^c		<0.0001
Fines (< 2.36 mm) (%)	0.80 ± 0.06 ^c	4.33 ± 0.09 ^a	3.67 ± 0.09 ^b	0.73 ± 0.07 ^c		<0.0001
Water stability (%)						
60 min (%)	94.83 ± 0.02 ^d	97.15 ± 0.06 ^{ab}	97.56 ± 0.31 ^a	96.92 ± 0.05 ^{bc}	96.49 ± 0.13 ^c	<0.0001
120 min (%)	93.57 ± 0.09 ^c	95.83 ± 0.10 ^b	96.53 ± 0.21 ^a	96.06 ± 0.06 ^{ab}	93.16 ± 0.25 ^c	<0.0001
240 min (%)	92.43 ± 0.14 ^c	94.78 ± 0.10 ^a	94.25 ± 0.40 ^{ab}	94.08 ± 0.07 ^b	94.26 ± 0.07 ^{ab}	<0.0001

^{a, b, c, d} Indicate significant differences ($p \leq 0.05$) among diets.

Table 5. Correlation among the physical quality parameters of two feed productions.

Variables	1	2	3	4	5	6	7	8	9	10	11	12
1 Length	-											
2 Diameter	0.11	-										
3 Bulk density	-0.89***	-0.18	-									
4 Hardness	-0.52*	-0.21	0.52*	-								
5 DORIS value	0.85***	0.24	-0.96***	-0.62*	-							
6 Intact pellets (> 8 mm)	-0.85***	-0.24	0.96***	0.62*	-1.00***	-						
7 Large fracture (5.6-8 mm)	0.82***	0.25	-0.95***	-0.57*	0.99***	-0.99***	-					
8 Small fracture (2.36-5.6 mm)	0.88***	0.21	-0.95***	-0.65***	0.99***	-0.99***	0.98***	-				
9 Fines (< 2.36 mm)	0.84***	0.28	-0.95***	-0.71***	0.98***	-0.98***	0.96***	0.98***	-			
10 Water stability (60 min)	-0.08	0.39 ^T	-0.01	0.56*	-0.09	0.09	-0.04	-0.14	-0.15	-		
11 Water stability (120 min)	-0.21	0.19	0.14	0.75***	-0.25	0.25	-0.19	-0.29	-0.33	0.89***	-	
12 Water stability (240 min)	-0.09	0.08	-0.09	0.52*	-0.06	0.06	-0.01	-0.12	-0.11	0.75***	0.84***	-

* $p < 0.05$ ** $p = 0.01$ *** $p < 0.001$ ^T $0.05 \leq p < 0.10$.

Table 6. Growth and feed performance of salmon fed the five experimental diets. The results are presented as mean \pm S.E.M.

	Diet A	Diet B	Diet C	Diet D	Diet E	ANOVA P<F
FBW, g	1964.36 \pm 182.94	1728.35 \pm 40.52	1686.61 \pm 143.35	1964.14 \pm 166.35	2017.58 \pm 181.19	0.4501
IBW, g	1004.90 \pm 58.11	935.81 \pm 7.70	936.49 \pm 16.03	947.34 \pm 32.85	1015.05 \pm 37.86	0.3637
WG, g	959.46 \pm 135.94	792.54 \pm 38.76	750.12 \pm 127.33	1016.80 \pm 133.59	1002.52 \pm 144.63	0.4393
FI, per fish, g	796.37 \pm 121.95	653.16 \pm 42.84	649.71 \pm 94.61	828.17 \pm 126.74	832.34 \pm 103.07	0.5395
FCR	0.83 \pm 0.02	0.83 \pm 0.03	0.88 \pm 0.06	0.81 \pm 0.02	0.83 \pm 0.02	0.7072
SGR, %	0.73 \pm 0.06	0.67 \pm 0.02	0.64 \pm 0.07	0.80 \pm 0.06	0.75 \pm 0.06	0.3499
SFR, %	0.60 \pm 0.05	0.56 \pm 0.03	0.55 \pm 0.06	0.65 \pm 0.06	0.62 \pm 0.04	0.6078
TGC	2.86 \pm 0.29	2.55 \pm 0.10	2.41 \pm 0.31	3.09 \pm 0.29	2.95 \pm 0.29	0.3992

FBW: final body weight.

IBW: initial body weight.

WG: weight gain.

FI: feed intake.

FCR: feed conversion ratio.

SGR: specific growth rate.

SFR: specific feeding rate.

TGC: thermal growth coefficient.

Table 7. Correlation among salmon growth performance parameters.

Variables	1	2	3	4	5	6	7	8
1 FBW	-							
2 IBW	0.85***	-						
3 WG	0.99***	0.77***	-					
4 FI, per fish	0.98***	0.80***	0.97***	-				
5 FCR	-0.19	0.02	-0.25	-0.03	-			
6 SGR	0.91***	0.57*	0.96***	0.91***	-0.34	-		
7 SFR	0.89***	0.62*	0.92***	0.96***	0.06	0.92***	-	
8 TGC	0.96***	0.67*	0.99***	0.95***	-0.29	0.99***	0.93***	-

* $p < 0.05$ ** $p = 0.01$ *** $p < 0.001$ ^T $0.05 \leq p < 0.10$.

FBW: final body weight.

IBW: initial body weight.

WG: weight gain.

FI: feed intake.

FCR: feed conversion ratio.

SGR: specific growth rate.

SFR: specific feeding rate.

TGC: thermal growth coefficient.

Table 8. Correlation among the physical quality and the fish growth performance parameters.

Variables	1	2	3	4	5	6	7	8	9	10	11	12	13	14	15	16	17	18	
1 Length	-																		
2 Diameter	-0.35	-																	
3 Bulk density	-0.89***	0.12	-																
4 Hardness	-0.81*	-0.03	0.98***	-															
5 DORIS value	0.89***	-0.09	-1.00***	-0.98***	-														
6 Intact pellets (>8mm)	-0.89***	0.09	1.00***	0.98***	-1.00***	-													
7 Large fracture (5.6mm-8mm)	0.87***	-0.08	-1.00***	-0.98***	1.00***	-1.00***	-												
8 Small fracture (2.36-5.6mm)	0.92***	-0.14	-1.00***	-0.97***	1.00***	-1.00***	0.99***	-											
9 Fines (< 2.36mm)	0.85***	-0.02	-0.99***	-0.98***	0.99***	-0.99***	0.99***	0.99***	-										
10 Water stability (60min)	-0.89***	0.31	0.82*	0.75*	-0.82*	0.83***	-0.82*	-0.83***	-0.80*	-									
11 Water stability (120min)	-0.79*	0.17	0.81*	0.73*	-0.80*	0.80*	-0.81*	-0.79*	-0.80*	0.74*	-								
12 Water stability (240min)	-0.35	0.24	0.23	0.10	-0.22	0.22	-0.22	-0.21	-0.23	0.47	0.66*	-							
13 WG	0.11	-0.07	-0.10	-0.16	0.11	-0.11	0.12	0.10	0.07	-0.36	0.08	0.23	-						
14 FI, per fish	0.14	-0.03	-0.09	-0.13	0.10	-0.10	0.11	0.10	0.07	-0.36	0.07	0.25	0.97***	-					
15 FCR	0.04	0.14	0.09	0.15	-0.10	0.09	-0.11	-0.08	-0.09	0.08	0.02	0.13	-0.18	0.06	-				
16 SGR	-0.06	-0.08	0.00	-0.07	0.00	0.00	0.02	-0.01	-0.03	-0.19	0.21	0.33	0.96***	0.90***	-0.30	-			
17 SFR	-0.04	-0.01	0.03	-0.02	-0.03	0.03	-0.02	-0.03	-0.05	-0.19	0.21	0.39	0.93***	0.97***	0.12	0.91***	-		
18 TGC	0.02	-0.07	-0.05	-0.11	0.05	-0.05	0.07	0.04	0.02	-0.27	0.15	0.29	0.99***	0.94***	-0.24	0.99***	0.93***	-	

* $p < 0.05$ ** $p = 0.01$ *** $p < 0.001$ ¹ $0.05 \leq p < 0.10$.

WG: weight gain.

FI: feed intake.

FCR: feed conversion ratio.

SGR: specific growth rate.

SFR: specific feeding rate.

TGC: thermal growth coefficient.

4. Discussion

The present study aimed to investigate the effect of moisture content on physical quality of feed as well as on feed intake, weight gain and feed utilization of Atlantic salmon. Four extruded diets were produced at standardized processing conditions and dried at different intensity to contain 2.5%, 5%, 7.5% and 10% of water, respectively. The diet containing 7.5% moisture was soaked in the salt water for 2 h to a moisture content of 90.6%. Even though the soaking procedure was the same as that used at Sunndalsøra, and the same standardized method was used to analyze DM, the DM content of soaked diets at Sunndalsøra and ÅS differed. A DM of 73.2% was obtained at Sunndalsøra while we analyzed DM of 90.6% at ÅS. One explanation to these differences may be that changes took place in the pellets during storage, affecting the water absorption capacity during the soaking. Overall, the chemical composition did not differ among the diets on a DM basis, except for increased element content (Mg, Na and Fe) of the soaked diets, reflecting the elements commonly found in seawater.

4.1 Effect of the moisture level on the physical quality of the pellets

Moisture content affected physical quality of pellets in the present experiment (Table 3). The soaked diet had the greatest diameter because the pellet expanded during the course of the soaking. Significant variation in length and diameter were observed among the other four extruded diets. Diet A with lowest moisture had the longest pellets compared to diet B, C and D. Small variation in extrusion parameters may explain the variation in diameter and length. Previous research has shown that reduced retention time caused by an increase in screw speed may increase pellet length (Lue et al., 1991; Lue et al., 1994; Sørensen et al., 2009). Sørensen et al. (2009) also reported that the variation of pellet diameter was affected by degree of expansion. Because the same die was used to produce all diets at standardized extruded parameters, the variation in diameter and length maybe explained by variation among batches in the production. It is also likely that changes in diameter and length took place during drying of the diets.

Bulk density is another important physical quality parameter of fish feeds that determines the sinking velocity of the pellets (Chevanan et al., 2007, 2009). Bulk density was influenced by

moisture content and increased with higher moisture level in the present experiment. Draganovic et al. (2011) used a volumetric displacement method to measure the density of three uncoated extruded feeds. In contrast to the present experiment, Draganovic et al. (2011) produced the feeds by adding 20, 26 and 32 g/100g moisture in the mash respectively, before drying to approximately 8% moisture. They showed that density of extruded pellets decreased with higher moisture content. These contradicting results indicates that pellets density vary with moisture level during extrusion, as well as extrusion processing parameters and drying intensity.

Different moisture level in the diets affected hardness of pellets in the present experiment. Diets C and D with the highest moisture level (7.5% and 10%) had the highest hardness. It is also interesting to note, that soaked pellet was harder than the pellet with 2.5% moisture. Low moisture content gave a more brittle pellet. Draganovic et al. (2011) reported that pellet hardness was reduced with increasing moisture content in the mash. The result from these two experiments indicated that also hardness of extruded pellets is affected by moisture level, as well as extrusion processing parameters and drying intensity.

Extruded feeds are brittle materials (Aarseth et al., 2006). The present study showed that DV decreased with higher moisture content in the diets. The diet with 2.5% moisture was more brittle, generated more fines and is thus more likely to generate fines in pneumatic feeding devices compared to the diets with higher moisture content. One explanation maybe that moisture itself act as a binder increasing adhesion between feed particles, improving the quality of extruded pellets as earlier reported for steam pelleted diets (Lundblad et al., 2009). In order to avoid fines, over drying and pellets with too low moisture content ($\leq 2.5\%$) should be avoided.

All the diets had high water stability after 240 min in shaking water bath with a stability ranging from 92.45% to 93.66%. Diet A had lower water stability compared to the other four diets after 60 min and 120 min in shaking water bath. However, after 240 min shaking time, diet E tended to have higher water stability ($P = 0.059$) than the other four diets. High water stability is associated with less leaching of nutrients when pellet are soaked water. However, earlier studies have reported that diets with low water stability gave separation and accumulation of free oil in the stomach of rainbow trout suffering from osmoregulatory stress

(Baeverfjord et al., 2006; Aas et al., 2011a). This condition is associated with oil belching in rainbow trout (Baeverfjord et al., 2006).

The correlation analysis among physical quality parameters in the present study showed that pellets with higher bulk density also was harder pellets and formed less dust (Table 5). The pellets with high hardness also showed greater water stability (Table 5). In line with this study, Aas et al. (2011a) reported that higher water stability of the pellets was associated with harder pellets and less broken pellets.

4.2 Fish growth performance

Although no significant differences were observed in FI, WG, SGR, SFR, TGC and FCR among the five diets, diets D and E showed numerically higher values (Table 6). The FCR in the present experiment was slightly lower than earlier reported for salmon of similar size (Aksnes, 1995; Einen and Roem, 1997; Sveier and Lied, 1998, Sveier et al., 1999). The SGR and TGC values are also in line with other published studies (Austreng et al., 1987; Sveier and Lied, 1998, Sveier et al., 1999). The numerically higher growth performance and feed utilization of diets D and E may suggest that higher moisture content in the pellets may stimulate the appetite resulting in greater FI. In line with this, Storebakken and Austreng (1988) reported increased dry matter intake in rainbow trout fed moist pellets compared to dry pellets. In particular increased FI was reported in fish fed moist pellets with approximately 60-70% dry matter at falling seawater temperature (Gabrielsen and Austreng, 1998). In contrast, Ruohonen et al. (1998) reported impaired growth of rainbow trout fed diets with 45-50% dry matter. The latter authors also reported that the trout compensated higher dietary moisture with a higher FI, suggesting that the FI on a dry matter basis was equal. Most previous research has investigated moist diets made from moist ingredients such as fish by-products. These diets maybe more prone to nutrient leakage than extruded diets. This is the first study to evaluate effects of different moisture content in extruded diets on growth performance and feed utilization. Extruded diets are more water stable and no nutrient leakage was observed for the soaked feed. Effect of moisture content on fish performance could thus be evaluated without a bias with nutrient leakage, or changing ingredient composition that have been weaknesses with previous published literature.

Nutrient digestibility was not tested in this part of the study. However, the fish growth performance parameters may indicate that higher moisture level in the diets facilitated digestion of the pellet and hence improved the growth rate of fish.

4.3 Interaction between physical quality of experimental diets and fish growth performance

The FI can be influenced by physical quality of pellets and availability of dietary nutrients (Houlihan et al., 2001). No significant correlation was observed among physical quality of experimental diets and fish growth performance. Diet E with the numerical highest water stability (at 240 min) showed a non-significant but numerically high FI fed to fish compared to the other diets. In line with the present findings, Baeverfjord et al. (2006) reported no significant differences in FI and growth rate when the rainbow trout was fed diets differing in water stability. In contrast to these findings, Aas et al. (2011a) showed that FI was significant higher in trout fed diets with low water stability compared to a diet with high water stability. Both Baeverfjord et al. (2006) and Aas et al. (2011a) suggested that diets with high water stability gave a longer gastric retention time, resulting in lower FI. However, in contrast to Baeverfjord et al. (2006) and Aas et al. (2011a), the variation in water stability among all diets was lower in the present study. Because of the low variation in water stability among diets, less variation among experimental units would be needed to detect significant differences in FI and weight gain.

The feeding experiment with diet from the first feed production was terminated because of low FI. It was therefore decided to produce new experimental diets based on the same ingredients, but with some modifications in physical quality. In general the pellets from the second feed production were slightly lighter, had lower hardness and were more brittle. These modifications in physical quality between the two productions may be caused by moderate changes in ingredient composition or by feed processing parameters. For example, high fat level (> 12%) during the extrusion process may decrease pellet durability (Rokey and Huber, 1994). Fat is an efficient lubricant in extruders, reducing the shear stress, plastification and cooking in the extruder. Increasing the fat level in the feed mash therefore results in poorer physical quality of pellets. Water added in the dough affects binding capacity among particles as well as starch gelatinization. Also high moisture content reduces the viscous dissipation

and melt viscosity (Ilo et al., 1996), thus affecting physical quality of the pellets (Draganovic et al., 2011). Processing parameters such as temperature, can further be used to change physical quality of pellets. Variation in physical quality may thus be changed by ingredient composition and processing condition. The feed refusal of the salmon fed diets from the first feed production may strengthen the hypothesis that there is an interaction between physical quality of pellet and FI. The slight modification in structure of the pellets from the second feed production was more acceptable for the fish.

5. Conclusion

The present experiment showed that, physical quality of extruded feed was significantly affected by moisture level. Higher moisture level improved the physical quality of pellets in terms of hardness, bulk density, DORIS durability and water stability. Moreover, pellets soaked in salt water for 2 h gave little or no changes in physical quality. The results also showed that higher bulk density was associated with harder pellets and lower DV. High pellet hardness gave a more water stable pellet.

Changing feed moisture in the range from 2.5% to 10% had no adverse effect on growth performance of Atlantic salmon. The diets with high moisture level (diet D, 10%) and diet E (soaked pellet) showed numerically higher feed intake and better weight gain than diets A-C with 2.5%, 5%, 7.5% moisture, respectively. Although no significant differences were noted, these results strongly indicated that high moisture in the pellet stimulated the appetite resulting in greater feed intake.

The present study is the first to report the effect of extruded pellet moisture content on physical quality of feed as well as weight gain, feed intake and feed utilization. More studies are needed to understand the underlying mechanisms of how feed moisture level affected physical and nutritional quality of fish feed.

6. References

- AARSETH, K. A., PEREZ, V., BOE, J. K., JEKSRUD, W. K., 2006. Reliable pneumatic conveying of fish feed. *Aquacultural Engineering*, 35, 14-25.
- AAS, T. S., TERJESEN, B. F., SIGHOLT, T., HILLESTAD, M., HOLM, J., REFSTIE, S., BAEVERFJORD, G., RØRVIK, K. A., SØRENSEN, M., OEHME, M., ÅSGÅRD, T., 2011a. Nutritional responses in rainbow trout (*Oncorhynchus mykiss*) fed diets with different physical qualities at stable or variable environmental conditions. *Aquaculture Nutrition*, 17, 657-670.
- AAS, T. S., OEHME, M., SØRENSEN, M., HE, G. J., LYGREN, I., ÅSGÅRD, T., 2011b. Analysis of pellet degradation of extruded high energy fish feeds with different physical qualities in a pneumatic feeding system. *Aquacultural Engineering*, 44, 25-34.
- AKSNES, A., 1995. Growth, feed efficiency and slaughter quality of salmon, *Salmo salar* L., given feeds with different ratios of carbohydrate and protein. *Aquaculture Nutrition*, 1, 241-248.
- ASKELAND, T., FJELLANGER, K., FLEM, N., 2002. The story of DORIS-improved control of the feed's physical quality. *Trouw Outlook* 18, 23-25.
- AUSTRENG, E., STOREBAKKEN, T., ÅSGÅRD, T., 1987. Growth rate estimates for cultured Atlantic salmon and rainbow trout. *Aquaculture*, 60, 157-160.
- BAEVERFJORD, G., REFSTIE, S., KROGEDAL, P., ÅSGÅRD, T., 2006. Low feed pellet water stability and fluctuating water salinity cause separation and accumulation of dietary oil in the stomach of rainbow trout (*Oncorhynchus mykiss*). *Aquaculture*, 261, 1335-1345.
- BARROWS, F. T., STONE, D. A. J., HARDY, R. W., 2007. The effects of extrusion conditions on the nutritional value of soybean meal for rainbow trout (*Oncorhynchus mykiss*). *Aquaculture*, 265, 244-252.
- BEYER, K., 2007. Preconditioning of pet foods, aquatic and livestock feeds. In: Riaz, M.N. (Ed.), *Extruder and expanders in pet food, aquatic and livestock feeds*. Agrimedia GmbH, Clenze, Germany, pp. 175-190.
- BRENT, J. L., 1999. Principles of extrusion cooking technology: single- and twin-screw extruders. In: Chang, Y. K. and Wang S. S. (Eds.), *Advances in extrusion technology*.

- Aquaculture/Animal feeds and foods. Technomic Publishing Company, Inc., Lancaster, PA. USA, pp. 73-83.
- CAI, W., DIOSADY, L. L., 1993. Model for gelatinization of wheat-starch in a twin-screw extruder. *Journal of Food Science*, 58, 872-887.
- CAMIRE, M. E., 2000. Chemical and nutritional changes in food during extrusion. In: Riaz, M. N. (Ed.), *Extruders in food applications*. Technomic Publishing Company, Inc., Lancaster, PA, USA, pp. 109-129.
- CAMIRE, M. E., 2001. Extrusion and nutritional quality. In: Guy, R. (Ed.), *Extrusion cooking, technologies and applications*. Woodhead Publishing Limited, Cambridge, pp. 108–129.
- CHEN, F. L., WEI, Y. M., ZHANG, B., 2011. Chemical cross-linking and molecular aggregation of soybean protein during extrusion cooking at low and high moisture content. *Lwt-Food Science and Technology*, 44, 957-962.
- CHEVANAN, N., MUTHUKUMARAPPAN, K., ROSENTRATER, K. A., JULSON, J. L., 2007. Effect of die dimensions on extrusion processing parameters and properties of DDGS-based aquaculture feeds. *Cereal Chemistry*, 84, 389-398.
- CHEVANAN, N., ROSENTRATER, K. A., MUTHUKUMARAPPAN, K., 2008. Effect of DDGS, moisture content, and screw speed on physical properties of extrudates in single-screw extrusion. *Cereal Chemistry*, 85, 132-139.
- CHEVANAN, N., MUTHUKUMARAPPAN, K., ROSENTRATER, K. A., 2009. Extrusion studies of aquaculture feed using distillers dried grains with soubles and whey. *Food Bioprocess Technol.* 2, 177-185.
- DENSTADLI, V., VESTRE, R., SVIHUS, B., SKREDE, A., STOREBAKKEN, T., 2006. Phytate degradation in a mixture of ground wheat and ground defatted soybeans during feed processing: Effects of temperature, moisture level, and retention time in small- and medium-scale incubation systems. *Journal of Agricultural and Food Chemistry*, 54, 5887-5893.
- DRAGANOVIC, V., VAN DER GOOT, A. J., BOOM, R., JONKERS, J., 2011. Assessment of the effects of fish meal, wheat gluten, soy protein concentrate and feed moisture on extruder system parameters and the technical quality of fish feed. *Animal Feed Science and Technology*, 165, 238-250.
- DREW, M. D., BORGESON, T. L., THIESSEN, D. L., 2007. A review of processing of feed ingredients to enhance diet digestibility in finfish. *Animal Feed Science and*

- Technology, 138, 118-136.
- EINEN, O., ROEM, A. J., 1997. Dietary protein/energy ratios for Atlantic salmon in relation to fish size: growth, feed utilization and slaughter quality. *Aquaculture Nutrition*, 3, 115-126.
- FAO, 2009. Impact of rising feed ingredient prices on aquafeeds and aquaculture production. FAO Fisheries and Aquaculture Technical Paper. No. 541. Rome, 63 pp.
- FAO, 2011. Aquaculture development. 5. Use of wild fish as feed in aquaculture. FAO Technical Guidelines for Responsible Fisheries, No. 5, Suppl. 5, Rome, 79 pp.
- FRANCIS, G., MAKKAR, H. P. S., BECKER, K., 2001. Antinutritional factors present in plant-derived alternate fish feed ingredients and their effects in fish. *Aquaculture*, 199, 197-227.
- FISKERIDIREKTORATET 2011. Statistikk: Foreløpig statistikk for akvakultur 2010. Fiskeridirektoratet Juni, 2011, 53 pp.
- GABRIELSEN, B. O., AUSTRENG, E., 1998. Growth, product quality and immune status of Atlantic salmon, *Salmo salar* L., fed wet feed with alginate. *Aquaculture Research*, 29, 397-401.
- GATLIN, D. M., BARROWS, F. T., BROWN, P., DABROWSKI, K., GAYLORD, T. G., HARDY, R. W., HERMAN, E., HU, G. S., KROGDAHL, A., NELSON, R., OVERTURE, K., RUST, M., SEALEY, W., SKONBERG, D., SOUZA, E. J., STONE, D., WILSON, R., WURTELE, E., 2007. Expanding the utilization of sustainable plant products in aquafeeds: a review. *Aquaculture Research*, 38, 551-579.
- GLENCROSS, B. D., BOOTH, M., ALLAN, G. L., 2007. A feed is only as good as its ingredients-a review of ingredient evaluation strategies for aquaculture feeds. *Aquaculture Nutrition*, 13, 17-34.
- GLENCROSS, B., HAWKINS, W., MAAS, R., KAROPOULOS, M., HAULER, R., 2010. Evaluation of the influence of different species and cultivars of lupin kernel meal on the extrusion process, pellet properties and viscosity parameters of salmonid feeds. *Aquaculture Nutrition*, 16, 13-24.
- GLENCROSS, B., HAWKINS, W., EVANS, D., RUTHERFORD, N., MCCAFFERTY, P., DODS, K., HAULER, R., 2011. A comparison of the effect of diet extrusion or screw-press pelleting on the digestibility of grain protein product when fed to rainbow trout (*Oncorhynchus mykiss*). *Aquaculture*, 312, 154-161.
- GUY, R. C. E., 2001. Raw materials for extrusion cooking. In: Guy, R. C. E. (Ed.), *Extrusion*

- cooking technologies and applications. Woodhead Publishing Limited, Cambridge, UK, pp. 5-28.
- GOGOI, B. K., CHOUDHURY, G. S., OSWALT, A. J., 1996. Effects of location and spacing of reverse screw and kneading element combination during twin-screw extrusion of starchy and proteinaceous blends. *Food Research International*, 29, 505-512.
- GROPPER, M., MORARU, C. L., KOKINI, J. L., 2002. Effect of specific mechanical energy on properties of extruded protein-starch mixtures. *Cereal Chemistry*, 79, 429-433.
- HARDY, R.W., 1989. Practical feeding: salmon and trout. In: Lovell. T. (Ed.), *Nutrition and feeding of fish*. Van Nostrand Reinhold, New York, pp. 185-203.
- HELLAND, S. J., GRISDALEHELLAND, B., NERLAND, S., 1996. A simple method for the measurement of daily feed intake of groups of fish in tanks. *Aquaculture*, 139, 157-163.
- HILTON, J. W., CHO, C. Y., SLINGER, S. J., 1981. Effect of extrusion processing and steam pelleting diets on pellet durability, pellet water absorption and the physiological response of rainbow trout (*Salmo Gairdneri*). *Aquaculture*, 25, 185-194.
- HOULIHAN, D., BOUJARD, T., JOBLING, M., 2001. *Food intake in fish*. Blackwell Science, Oxford, UK, 418 pp.
- IBRAHIM, S. S., HABIBA, R. A., SHATTA, A. A., EMBABY, H. E., 2002. Effect of soaking, germination, cooking and fermentation on antinutritional factors in cowpeas. *Nahrung-Food*, 46, 92-95.
- ILO, S., TOMSCHIK, U., BERGHOFER, E., MUNDIGLER, N., 1996. The effect of extrusion operating conditions on the apparent viscosity and the properties of extrudates in twin-screw extrusion cooking of maize grits. *Food Science and Technology*, 29, 593-598.
- KRAUGERUD, O. F., 2008. Physical and nutritional properties of polysaccharides in extruded fish feed. *Philosophiae Doctor (PhD) Thesis 2008: 29*, Department of Animal and Aquacultural Sciences, Norwegian University of Life Sciences, Ås, Norway, 170 pp.
- KRAUGERUD, O. F., JØRGENSEN, H. Y., SVIHUS, B., 2011. Physical properties of extruded fish feed with inclusion of different plant (legumes, oilseeds, or cereals) meals. *Animal Feed Science and Technology*, 163, 244-254.
- KROGDAHL, Å., HEMRE, G. -I., MOMMSEN, T. P., 2005. Carbohydrates in fish nutrition: digestion and absorption in postlarval stages. *Aquaculture Nutrition*. 11, 103-122.

- LUE, S., HSIEH, F., HUFF, H. E., 1991. Extrusion cooking of corn meal and sugar beet fiber: effects on expansion properties, starch gelatinization, and dietary fiber content. *Cereal Chemistry*, 68, 227-234.
- LUE, S., HSIEH, F., HUFF, H. E., 1994. Modeling of twin-screw extrusion cooking of corn meal and sugar beet fiber mixtures. *Journal of Food Engineering*, 21, 263-289.
- LUNDBLAD, K. K., 2009. Effect of diet conditioning on physical and nutritional quality of feed for pigs and chickens. *Philosophiae Doctor (PhD) Thesis 2009: 4*, Department of Animal and Aquacultural Sciences, Norwegian University of Life Sciences, Ås, Norway, 103 pp.
- LUNDBLAD, K. K., ISSA, S., HANCOCK, J. D., BEHNKE, K. C., MCKINNEY, L. J., ALAVI, S., PRESTLØKKEN, E., FLEDDERUS, J., SØRENSEN, M., 2011. Effects of steam conditioning at low and high temperature, expander conditioning and extruder processing prior to pelleting on growth performance and nutrient digestibility in nursery pigs and broiler chickens. *Animal Feed Science and Technology*, 169, 208-217.
- MORKEN, T., 2011. Upgrading plant ingredients in feed for salmonids by thermo-mechanical treatment and acids salts. *Philosophiae Doctor (PhD) Thesis 2011: 32*, Department of Animal and Aquacultural Sciences, Norwegian University of Life Sciences, Ås, Norway, 119 pp.
- MORKEN, T., KRAUGERUD, O. F., BARROWS, F. T., SØRENSEN, M., STOREBAKKEN, T., ØVERLAND, M., 2011. Sodium diformate and extrusion temperature affect nutrient digestibility and physical quality of diets with fish meal and barley protein concentrate for rainbow trout (*Oncorhynchus mykiss*). *Aquaculture*, 317, 138-145.
- MUNDHEIM, H., AKSNES, A., HOPE, B., 2004. Growth, feed efficiency and digestibility in salmon (*Salmo salar* L.) fed different dietary proportions of vegetable protein sources in combination with two fish meal qualities. *Aquaculture*, 237, 315-331.
- OPSTVEDT, J., MILLER, R., HARDY, R. W., SPINELLI, J., 1984. Heat-induced changes in sulfhydryl-groups and disulphide bonds in fish-protein and their effect on protein and amino-acid digestibility in rainbow trout (*Salmo gairdneri*). *Journal of Agricultural and Food Chemistry*, 32, 929-935.
- ØVERLAND, M., SØRENSEN, M., STOREBAKKEN, T., PENN, M., KROGDAHL, Å., SKREDE, A., 2009. Pea protein concentrate substituting fish meal or soybean meal in

- diets for Atlantic salmon (*Salmo salar*)-Effect on growth performance, nutrient digestibility, carcass composition, gut health, and physical feed quality. *Aquaculture*, 288, 305-311.
- REFSTIE, S., GLENCROSS, B., LANDSVERK, T., SØRENSEN, M., LILLEENG, E., HAWKINS, W., KROGDAHL, Å., 2006. Digestive function and intestinal integrity in Atlantic salmon (*Salmo salar*) fed kernel meals and protein concentrates made from yellow or narrow-leafed lupins. *Aquaculture*, 261, 1382-1395.
- ROKEY, G. J., HUBER, G., 1994. Petfood and fishfood extrusion. In: Frame, N. D. (Ed.), *The Technology of Extrusion Cooking*. Blackie Academic & Professional, London, UK, pp. 144-190.
- ROKEY, G. J., 2000. *Single screw extruders*. Technomic Publishing Company, Inc., Lancaster, PA, USA, pp. 25-50.
- ROMARHEIM, O. H., 2007. Nutritional responses to fish feed processing and differently pre-heated soybean meals. *Philosophiae Doctor (PhD) Thesis 2007: 10*, Department of Animal and Aquacultural Sciences, Norwegian University of Life Sciences, Ås, Norway, 154 pp.
- RUOHONEN, K., VIELMA, J., GROVE, D. J., 1998. High dietary inclusion level of fresh herring impairs growth of rainbow trout, *Oncorhynchus mykiss*. *Aquaculture*, 163, 263-273.
- SARGENT, J. R., TOCHER, D.R., BELL, J. G., 2002. The lipids. In: Halver, J. E., Hardy, R. W. (Eds.), *Fish Nutrition*, 3rd edition. Academic Press, San Diego, CA, USA, pp. 181-247.
- SCHOFIELD, E. K., 2005. *Feed manufacturing technology V*, Arlington, Va, American Feed Industry Association, AFIA, 670 pp.
- SHANKAR, J., BANDYOPADYAY, S., 2005. Process variables during single-screw extrusion of fish and rice flour blends. *Journal of Food Processing and Preservation* 29, 151-164.
- SINGH, S., GAMLATH, S., WAKELING, L., 2007. Nutritional aspects of food extrusion: a review. *International Journal of Food Science and Technology*, 42, 916-929.
- SMITH, O. B., 1976. Extrusion cooking. In: Altschul, A. M. (Ed.), *New protein foods*. Academic Press, New York, USA, pp. 86-120.
- SØRENSEN, M., 2003. Nutritional and physical quality of fish feeds extruded at various temperatures. *Philosophiae Doctor (PhD) Thesis 2003: 3*, Department of Animal and

- Aquacultural Sciences, Norwegian University of Life Sciences, Ås, Norway, 143 pp.
- SØRENSEN, M., STOREBAKKEN, T., SHEARER, K. D., 2005. Digestibility, growth and nutrient retention in rainbow trout (*Oncorhynchus mykiss*) fed diets extruded at two different temperatures. *Aquaculture Nutrition*, 11, 251-256.
- SØRENSEN, M., STJEPANOVIC, N., ROMARHEIM, O. H., KREKLING, T., STOREBAKKEN, T., 2009. Soybean meal improves the physical quality of extruded fish feed. *Animal Feed Science and Technology*, 149, 149-161.
- SØRENSEN, M., NGUYEN, G., STOREBAKKEN, T., ØVERLAND, M., 2010. Starch source, screw configuration and injection of steam into the barrel affect the physical quality of extruded fish feed. *Aquaculture Research*, 41, 419-432.
- SØRENSEN, M., MORKEN, T., KOSANOVIC, M., ØVERLAND, M., 2011a. Pea and wheat starch possess different processing characteristics and affect physical quality and viscosity of extruded feed for Atlantic salmon. *Aquaculture Nutrition*, 17, 326-336.
- SØRENSEN, M., BERGE, G. M., THOMASSEN, M., RUYTER, B., YTREST YL, T., AAS, T. S., ÅSGÅRD, T., 2011b. Today's and tomorrow's feed ingredients in Norwegian aquaculture. Nofima report, Nofima Tromsø, Norway, 68 pp.
- SØRENSEN, M., 2012. A review of the effects of ingredient composition and processing conditions on the physical qualities of extruded high-energy fish feed as measured by prevailing methods. *Aquaculture Nutrition*, 18, 233-248.
- STOREBAKKEN, T., AUSTRENG, E., 1988. Feed intake measurements in fish using radioactive isotopes: I. Experiments with rainbow trout in fresh water. *Aquaculture*, 70, 269-276.
- STRAHM, B. S., 2000. Preconditioning. In: Riaz, M. N. (Ed.), *Extruders in food applications*. Technomic Publishing Company, Inc., Lancaster, PA. USA, pp. 115-126.
- SVEIER, H., LIED, E., 1998. The effect of feeding regime on growth, feed utilisation and weight dispersion in large Atlantic salmon (*Salmo salar* L.) reared in seawater. *Aquaculture*, 165, 333-345.
- SVEIER, H., WATHNE, E., LIED, E., 1999. Growth, feed and nutrient utilisation and gastrointestinal evacuation time in Atlantic salmon (*Salmo salar* L.): the effect of dietary fish meal particle size and protein concentration. *Aquaculture*, 180, 265-282.
- SVIHUS, B., UHLEN, A. K., HARSTAD, O. M., 2005. Effect of starch granule structure, associated components and processing on nutritive value of cereal starch: A review.

- Animal Feed Science and Technology, 122, 303-320.
- THOMAS, M., VAN DER POEL, A. F. B., 1996. Physical quality of pelleted animal feed. 1. Criteria for pellet quality. Animal Feed Science and Technology, 61, 89-112.
- THOMAS, M., VAN ZUILICHEM, D. J., VAN DER POEL, A. F. B., 1997. Physical quality of pelleted animal feed. 2. Contribution of processes and its conditions. Animal Feed Science and Technology, 64, 173-192.
- VENOU, B., ALEXIS, M. N., FOUNTOULAKI, E., HARALABOUS, J., 2009. Performance factors, body composition and digestion characteristics of gilthead sea bream (*Sparus aurata*) fed pelleted or extruded diets. Aquaculture Nutrition, 15, 390-401.
- YOSHITOMI, B., 2004. Effect of extrusion cooking temperature on the microstructure of extruded pellets. Fisheries Science, 70, 1157-1163.